

Mini-Dahling Pendant

HS621_ 1.2



GENERAL PRODUCT INFORMATION:



This product is ETL listed and suitable only for indoor dry locations and approved for use at any height above the finished floor.



Assemble the Fixture

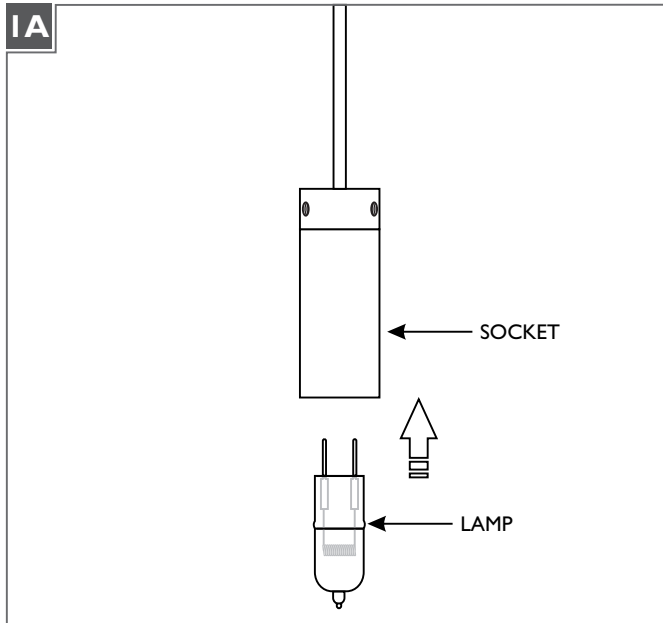

For incandescent versions, use **MAX 50 Watt** Type Xelogen (Xenon) Bi-Pin Lamp. 

CAUTION: RISK OF FIRE
Never replace a Xenon lamp with a regular Halogen lamp. A Halogen lamp requires a protective glass shield.

For LED versions, use provided **MAX 8 Watt** LED Bi-Pin Lamp.

1 Push the lamp pins completely into the socket holes.

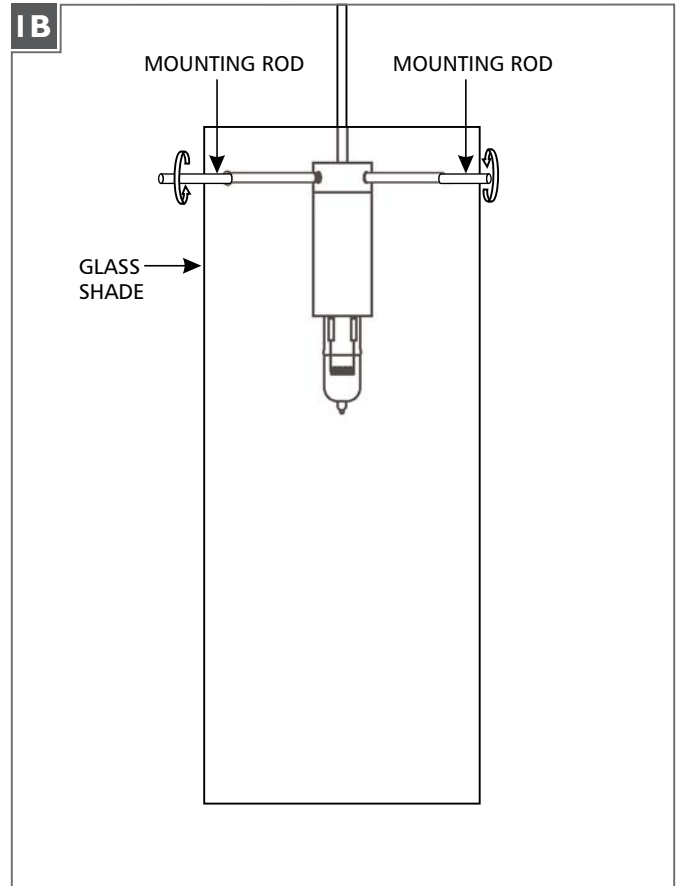

2 Place the hardware inside the glass shade and install the three mounting rods by screwing them in completely.

Adjust the Fixture Height

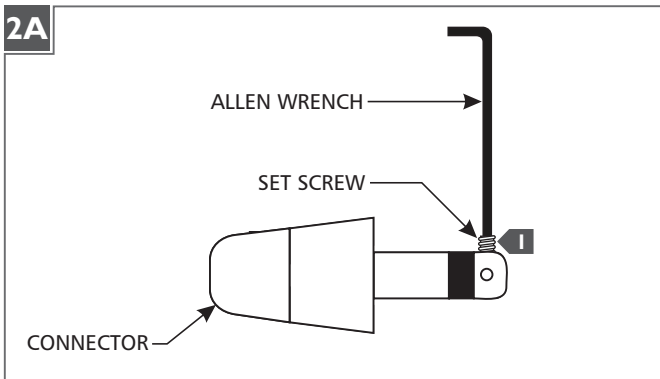

- 1 Back out (do not remove) the set screw on tip of the connector with the provided Allen wrench.

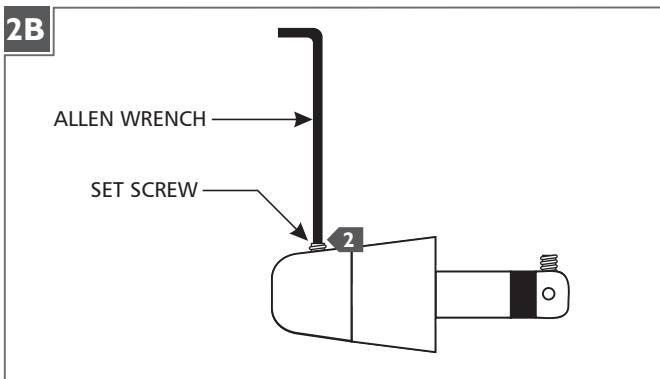

- 2 Back out (do not remove) the set screw on the conical connector with the provided Allen wrench.

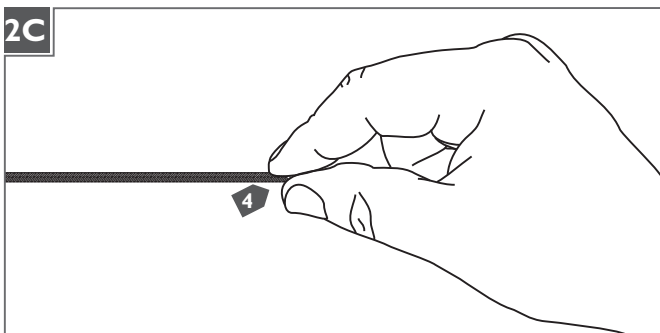

- 3 Cut the coaxial cable to the desired length.
- 4 Gently twist the end of the coaxial cable between thumb and forefinger.

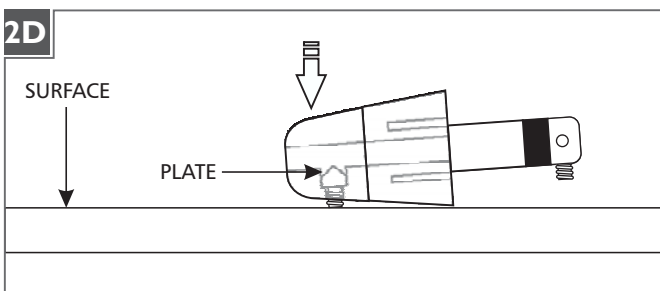

- 5 Tap the conical connector on a hard surface with the set screw facing down, so the plate inside drops into place.

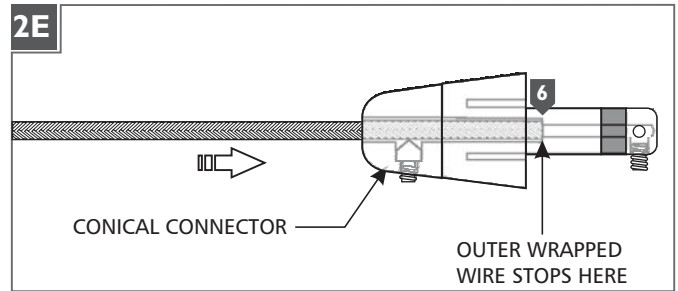

- 6 Feed and push the coaxial cable into the conical connector. The coaxial cable will come to a stop point after being inserted 3/4" into the conical connector.

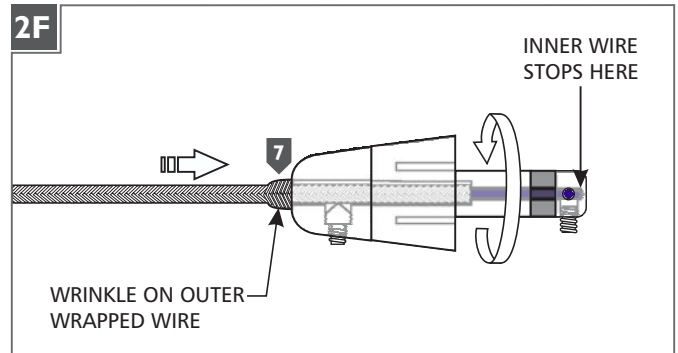

- 7 Keep pushing the coaxial cable into the connector while rotating the connector to ease feeding the inner wire into the tip of the connector. The outer wrapped wire will start wrinkling while being inserted another 1/2" into the connector.

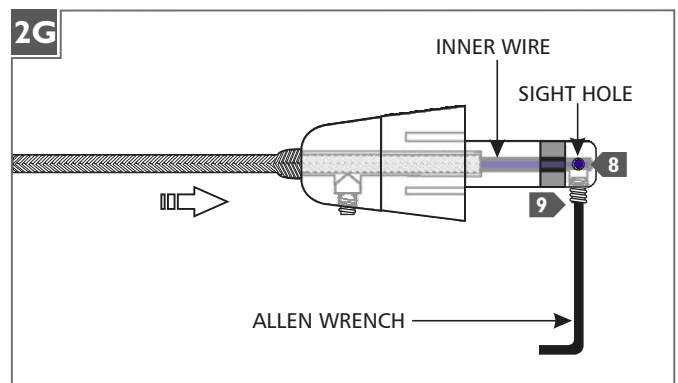

- 8 Look into the sight hole on the top of the connector to make sure that the inner wire is contacting the end of the connector.
- 9 Hold the coaxial cable in place and tighten the set screw on tip of the connector with the provided Allen wrench. Make sure this set screw connection is tight.

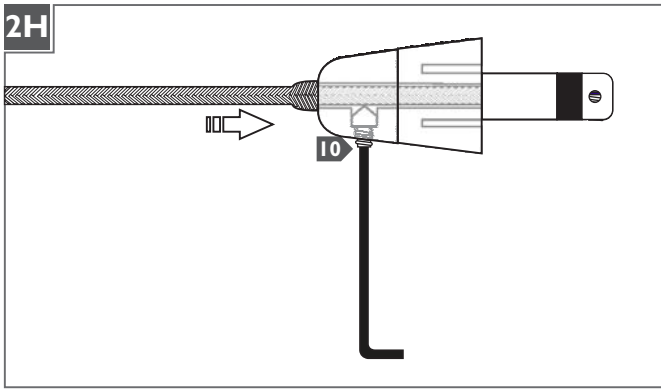

10 Firmly tighten the set screw on the conical connector.

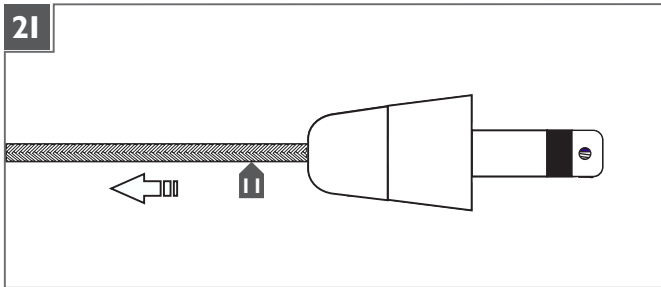

11 Pull the coaxial cable toward the fixture to smooth the wrinkles.

Replacing the Lamp

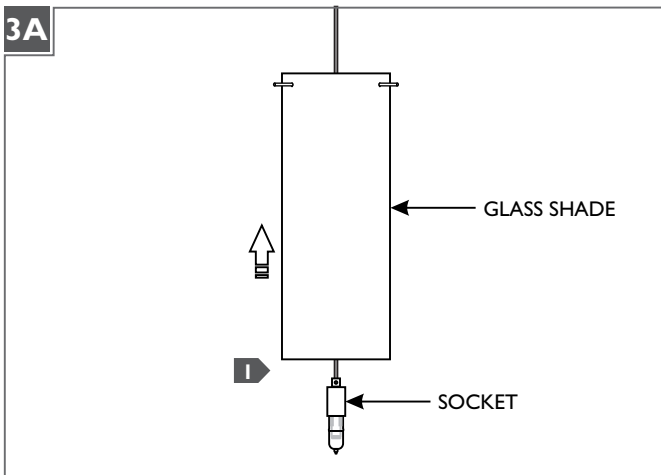

NOTE: To reduce the risk of a burn or electric shock during relamping, disconnect the power to the fixture.

1 Lift the glass shade up to expose the lamp and socket.

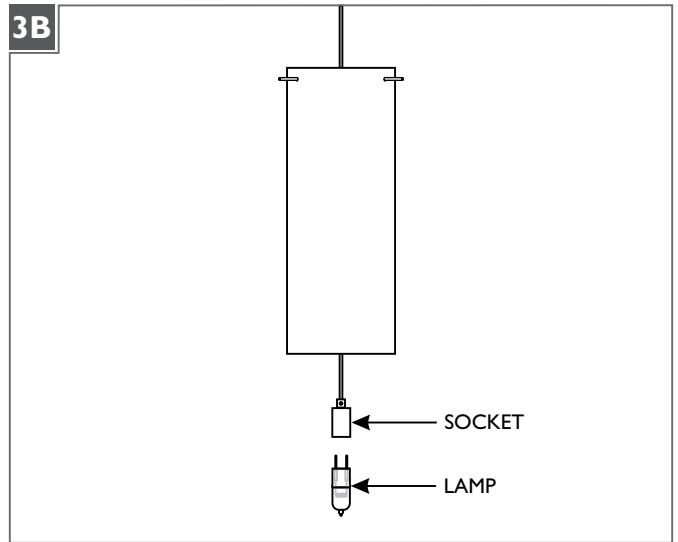

For incandescent versions, use **MAX 50 Watt** Type Xelogen (Xenon) Bi-Pin Lamp. 

CAUTION: RISK OF FIRE
Never replace a Xenon lamp with a regular Halogen lamp. A Halogen lamp requires a protective glass shield.

For LED versions, use provided **MAX 8 Watt** LED Bi-Pin Lamp.

2 Remove the old lamp.

3 Push the new lamp pins completely into the socket holes.

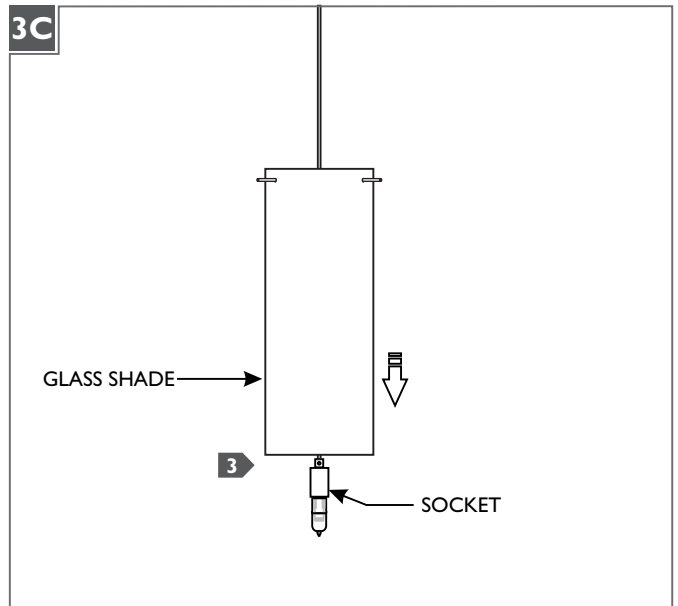

4 Lower the glass shade until the socket is properly inside the socket assembly.

SAVE THESE INSTRUCTIONS!

LBL

7400 Linder Ave, Skokie, IL 60077

800.323.3226 - 847.626.6300

www.lblighting.com

© 2015 LBL Lighting. All rights reserved. The "LBL Lighting" graphic is a registered trademark of LBL Lighting. LBL Lighting reserves the right to change specifications for product improvements without notification.

A Generation Brands Company