

Tube I

HS2931FR_IB35MRL 1.2



GENERAL PRODUCT INFORMATION:



This product is ETL listed and suitable only for indoor dry locations and approved for use at any height above the finished floor.

This product is intended to be used with LBL Monorail system.



Connect the Fixture Arm

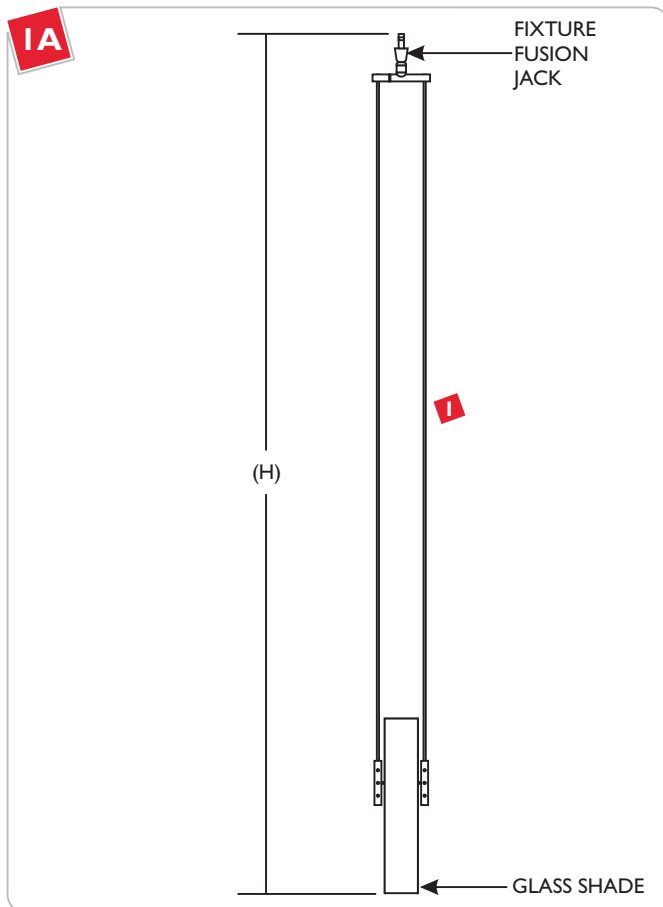

1 The overall fixture height (H) is measured from bottom of the glass shade to the end of the fixture Fusion Jack. Determine the overall desired fixture height. The overall fixture height (H) is 39" inches when the fixture rods are not cut.

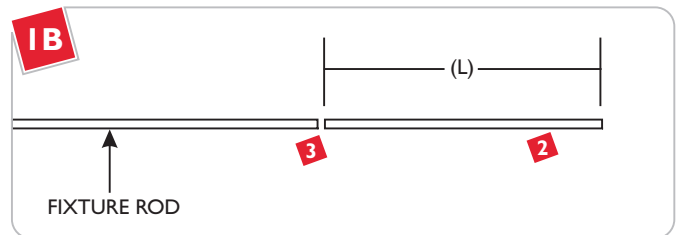

2 Mark amount (L) from one end of the fixture rod that needs to be cut shorter. **(Optional)**

NOTE: To avoid interference while relamping do not cut the fixture rods (L) more than 24" inches.

3 Cut the fixture arms with a sharp cutter. **(Optional)**

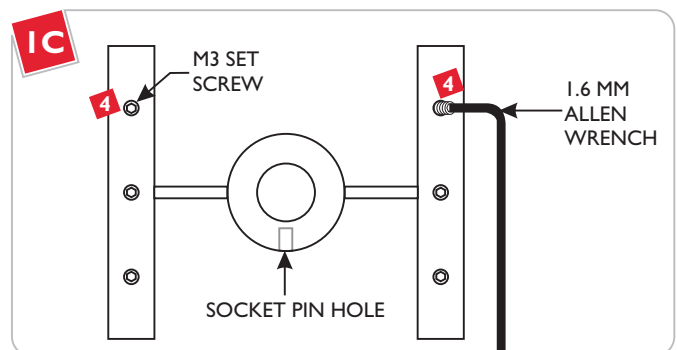

4 Loosen **(Do Not Remove)** the two M3 set screws on the socket assembly rods that are located on the opposite side of socket pin holes.

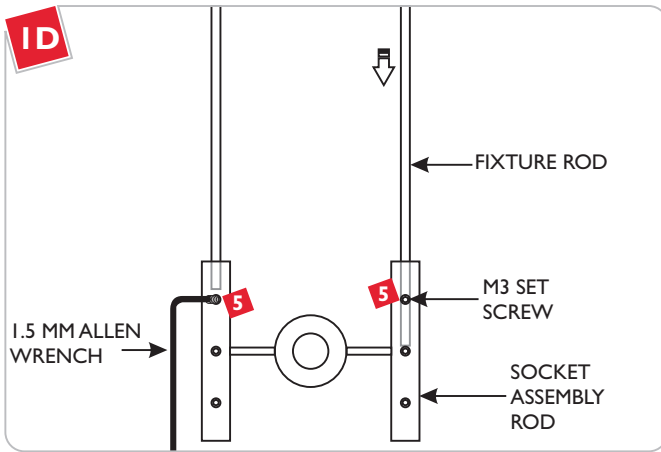

- 5** Insert the two fixture rods completely into the socket assembly rods and secure them in place by tightening the M3 set screws with the provided 1.5 MM Allen wrench.

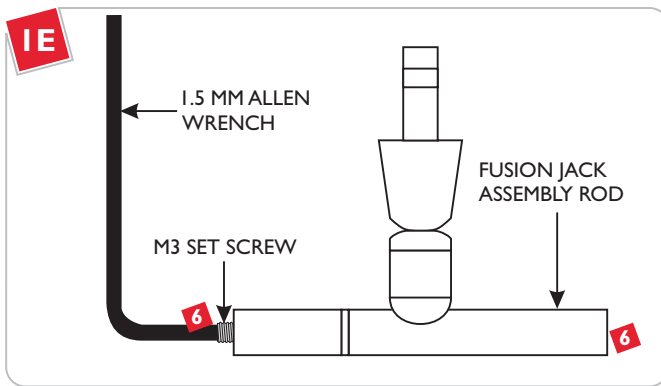

- 6** Loosen (**Do Not Remove**) the two M3 set screws on the sides of the Fusion Jack assembly rod with the provided 1.5 MM Allen wrench.

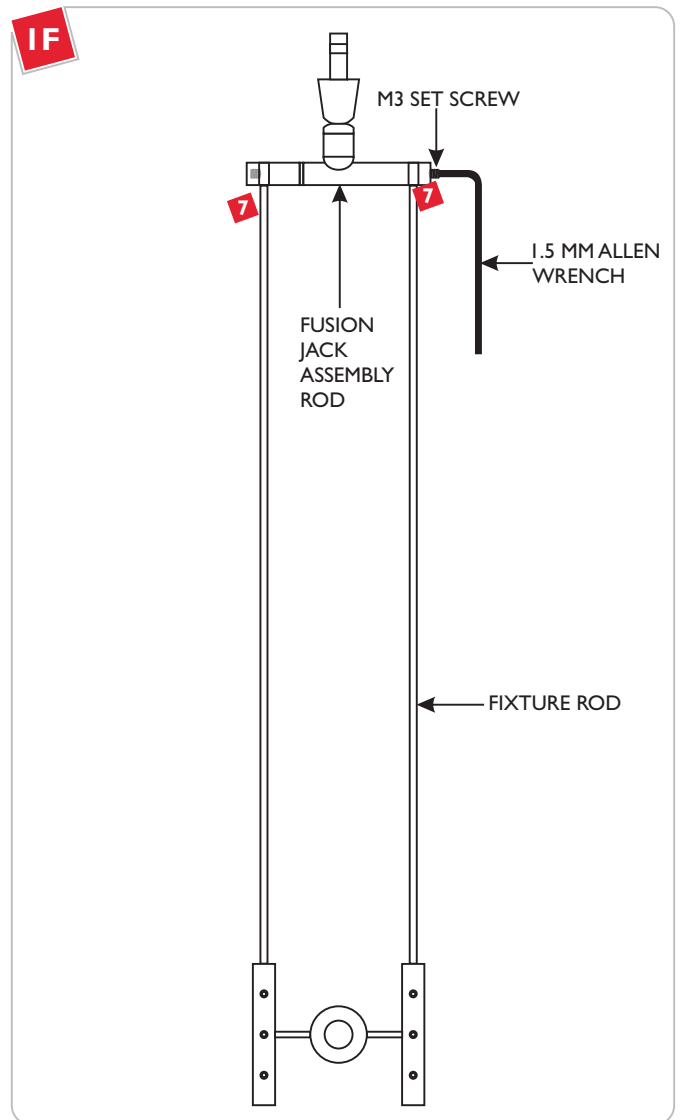

- 7** Insert the fixture rods into the Fusion Jack assembly rod, make sure the fixture rods are aligned with the top of the Fusion Jack assembly rod. Tighten the two M3 set screw with 1.5 MM Allen wrench.

Install the Lamp

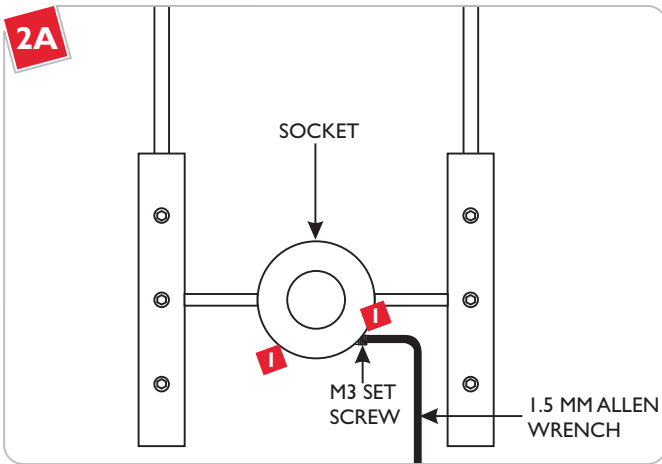

NOTE: To reduce the risk of a burn or electric shock during relamping, disconnect the power to the fixture.

- 1 Loosen (**Do Not Remove**) the two M3 set screws on the socket with the 1.5 mm Allen wrench.

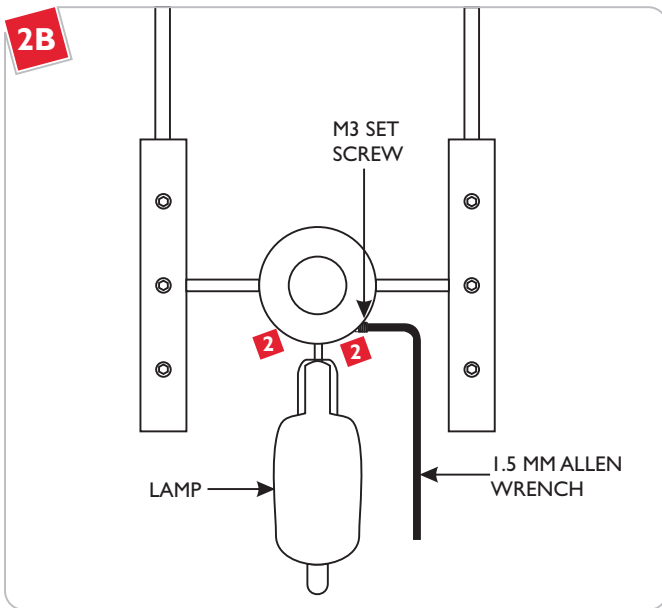

NOTE: Use only your fingers and soft cloth to replace the lamp.

Use **MAX 35 Watt, Type Xenogen (Xenon) Bi-Pin Lamp.**

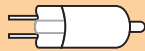

- 2 Push the lamp pins completely into the socket holes and tighten the two M3 set screws with the 1.5 mm Allen wrench to secure lamp in place.

WARNING: RISK OF FIRE

Never replace a Xenon (Xelogen) lamp with a regular Halogen lamp. A regular Halogen lamp requires a protective glass shield.

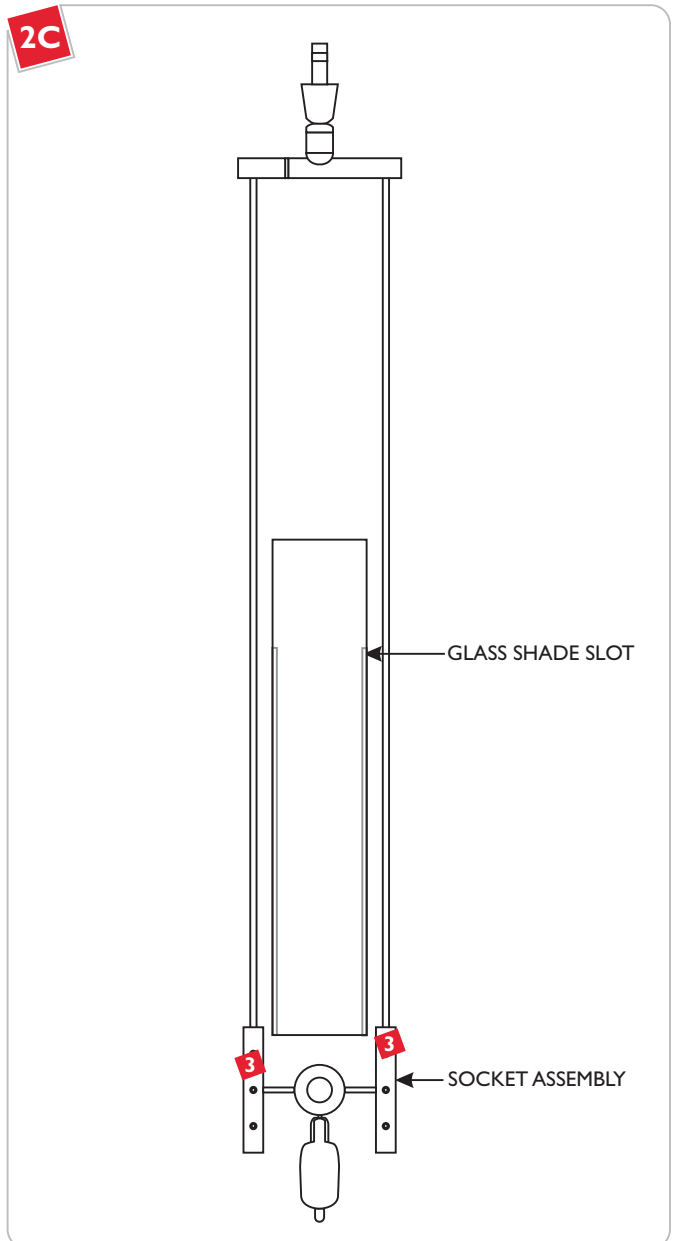

- 3 From between the fixture rods, carefully place the glass shade onto the socket assembly.

Install the Fixture to Monorail

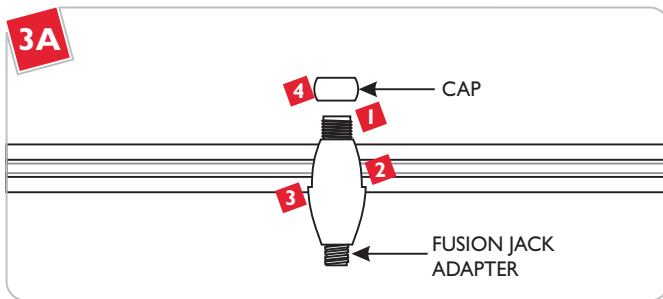

- 1 Unscrew the cap from the Fusion Jack adapter.
- 2 Select a place on the Monorail where the fixture is going to be mounted.
- 3 From the bottom, place the Fusion Jack adapter onto the Monorail.
- 4 Replace and tighten the cap to the Fusion Jack adapter. **Make sure that the cap is not cross threaded.**

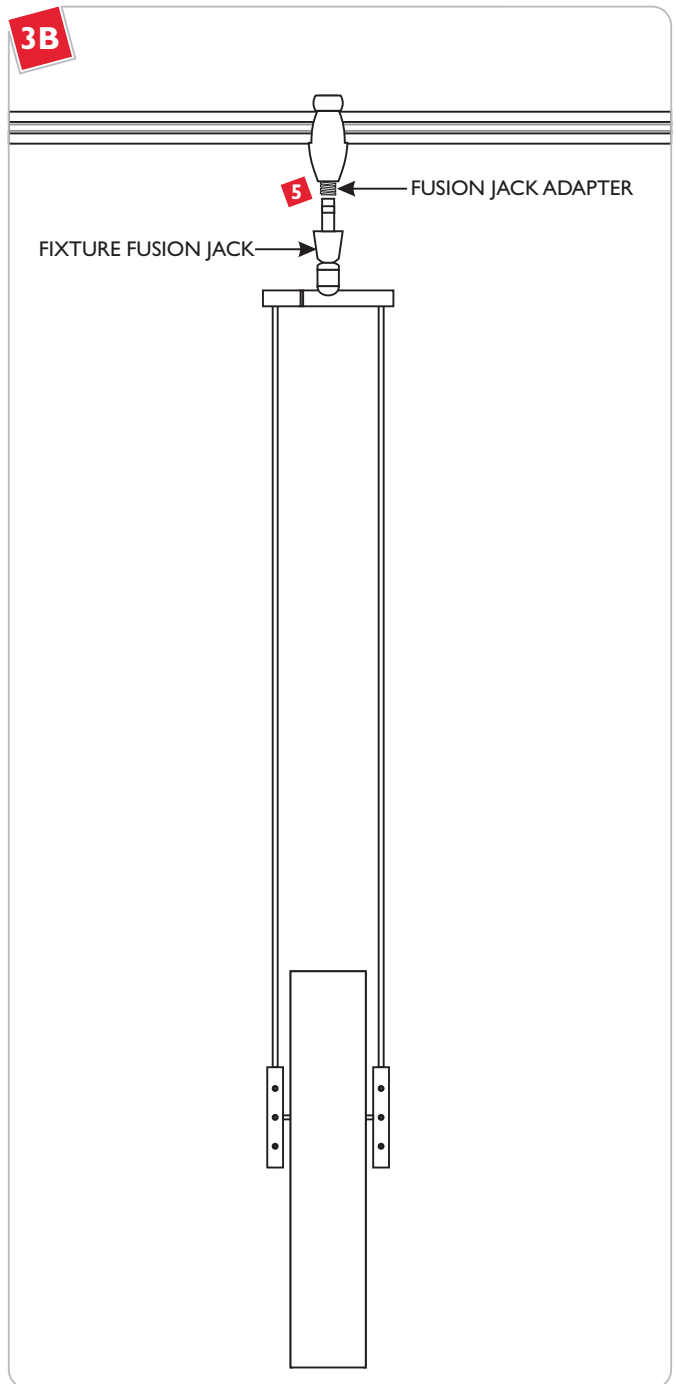

- 5 Push and screw the fixture Fusion Jack completely into the Fusion Jack adapter.

SAVE THESE INSTRUCTIONS!

 **LBL Lighting**

7400 Linder Ave, Skokie, IL 60077
800.323.3226 - 847.626.6300

www.lblighting.com

© 2008 LBL Lighting. All rights reserved. The "LBL Lighting" graphic is a registered trademark of LBL Lighting. LBL Lighting reserves the right to change specifications for product improvements without notification.

A Generation Brands Company