

vitra horizontal led brick light

DESCRIPTION

Vitra Horizontal LED Brick Light from LBL Lighting provide a perfectly balanced blend of the latest LED light guide technology. Small form factor, die-cast metal and premium finishes ensures enduring aesthetic appeal while being backed by a five-year warranty. LED includes 8.6 watt 300 lumen 90 CRI 3000K LED module. Dimmable with a low-voltage electronic dimmer. Turtle light version FCA compliant. May be used in interior and exterior applications. IP-65 rated. Installs into brick or poured concrete using included metal housing and require a minimum depth of 3.1". Interior/dry wall installation requires optional Hanger Bar Installation Kit #BL94018. ADA compliant.



WEIGHT

2.65lb / 1.2kg ±

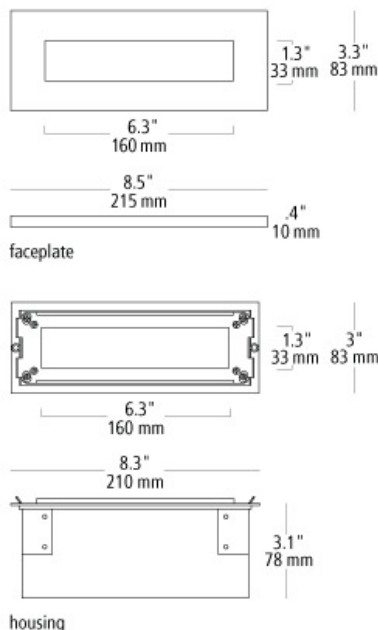

antique bronze satin nickel white

ORDERING INFORMATION

type	finish	lamp	wet location
BL94405	BZ antique bronze	LED930 LED module 5w 90 CRI 3000K 120v	W wet location
	SC satin nickel	LED930277 LED module 5w 90 CRI 3000K 277v	
	WH white	LEDTL LED module 5w Turtle Light 120v	
		LEDTL277 LED module 5w Turtle Light 277v	

FIXTURE TYPE: _____
 JOB NAME: _____
 NOTES: _____



7400 Linder Avenue
 Skokie, Illinois 60077
 T 847.626.6300
 F 847.626.6350

www.lblighting.com



©2016 LBL Lighting. All Rights Reserved. The "LBL Lighting" graphic is a registered trademark of LBL Lighting. LBL Lighting reserves the right to change specifications for product improvements without notification.