

East River Suspension

SU770_ 1.0



GENERAL PRODUCT INFORMATION:

This product is suitable for damp locations.

This product may be dimmed with a low-voltage electronic dimmer.



CAUTION - RISK OF FIRE
 This product must be installed in accordance with the applicable installation code by a person familiar with the construction and operation of the product and the hazards involved.
 Use minimum 90°C supply conductors.

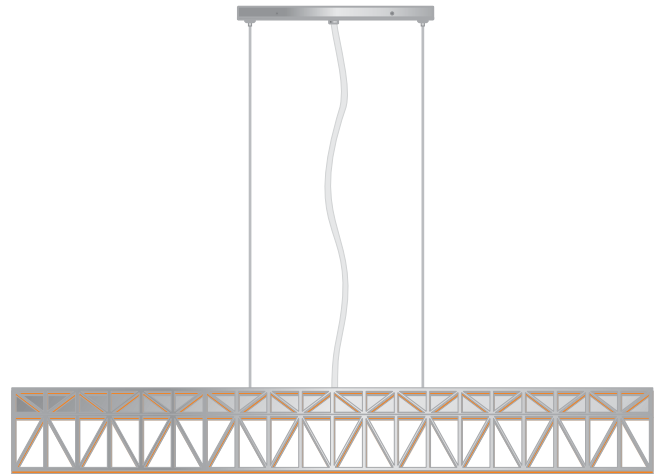

Install the Mounting Plate

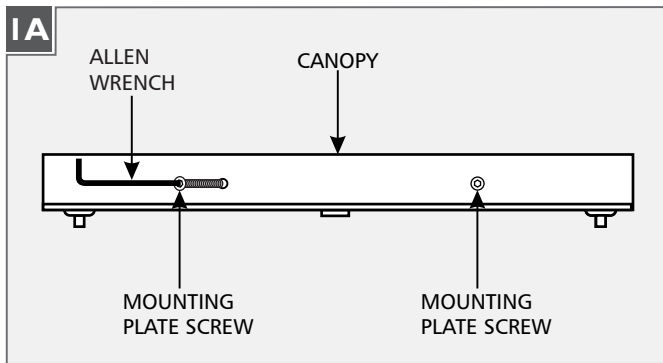

1 With the Allen wrench provided, separate the mounting plate from the canopy by removing all four mounting plate screws.

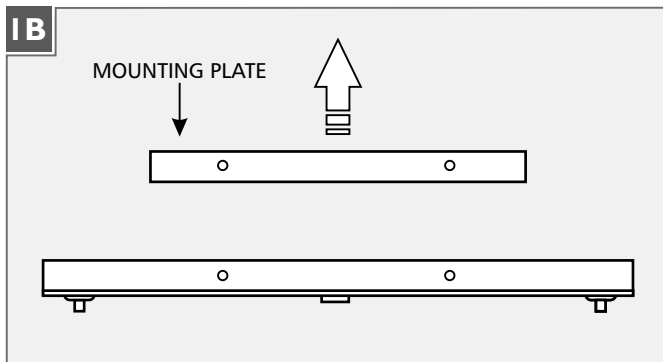

2 Remove the mounting plate from the canopy.

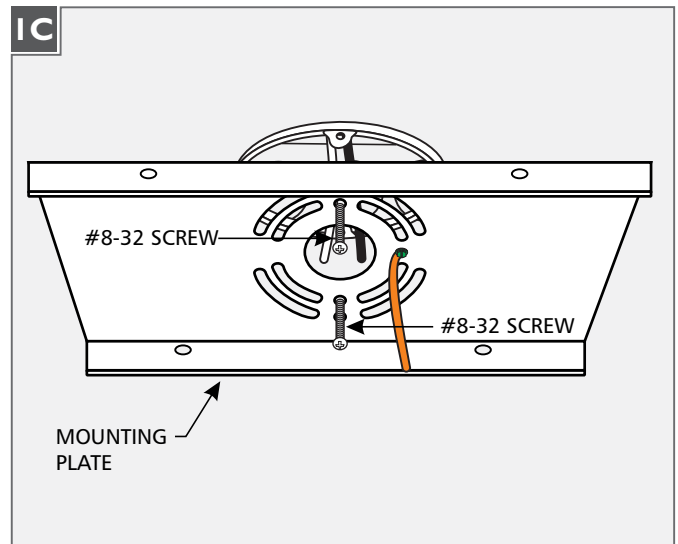

3 Secure the mounting plate to the electrical box with the two #8-32 screws provided.

Assemble the Fixture

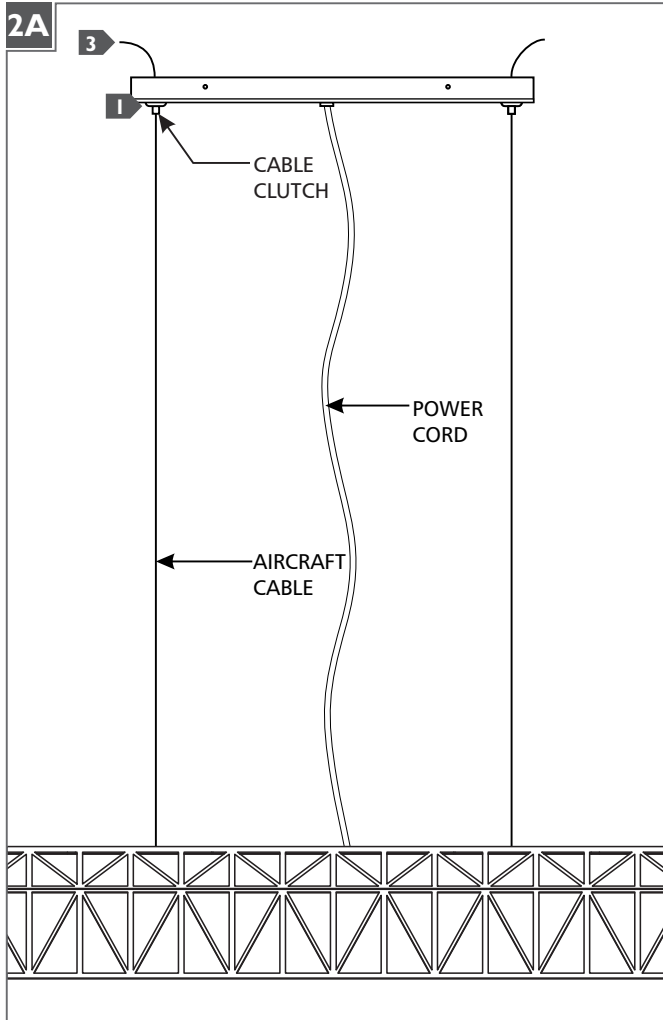

NOTE: Make sure to support the fixture while adjusting the aircraft cables. An assistant is recommended to complete the remaining steps.

- 1** Feed the aircraft cables through the cable clutches in the canopy.
- 2** Evenly pull the aircraft cable up through the canopy to raise the fixture to the desired length.
- 3** Cut off the excess aircraft cable leaving enough for fine leveling later.

Adjust the Power Cord

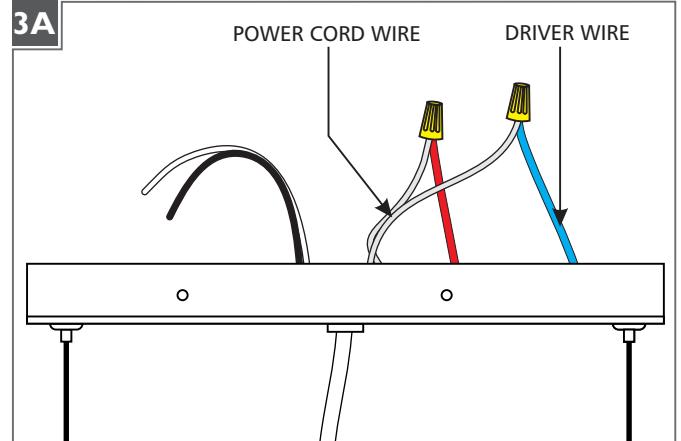

- 1** Take note of the wire connections and remove the wire nuts to disconnect the power cord wires from the driver wires.

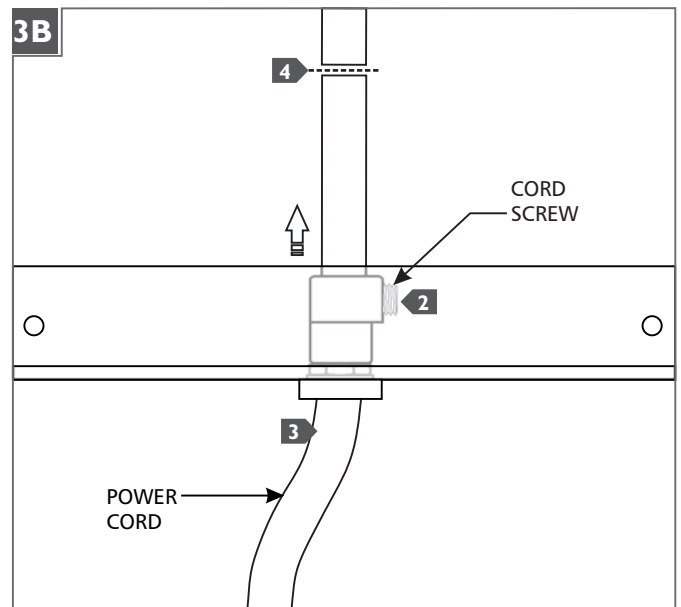

NOTE: The power cord does not support the fixture. For a casual "lazy cord" look, cut the power cord several inches longer than the drop height of the fixture.

- 2** Loosen the cord screw.
- 3** Pull the power cord through the canopy until it reaches the length desired.
- 4** Leave 6 inches of cord behind the canopy and cut off extra cord.

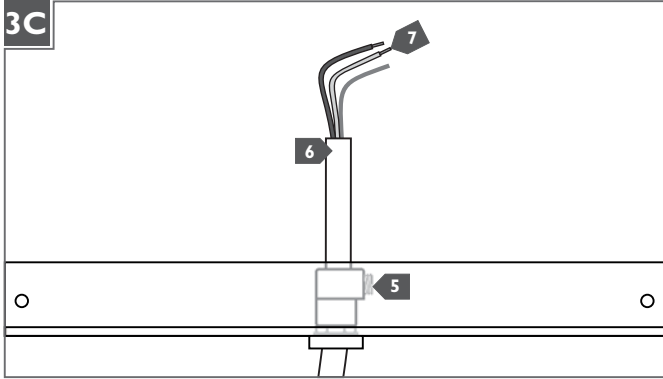

- 5 Tighten the cord screw.
- 6 From the end of the cord, strip the insulation 4" using a sharp knife. **Make sure not to nick the inner wires.**
- 7 Cut off the extra cord, strip 1/2" off the wire ends, and reconnect the power cord wires to their original connections (reversal of 3A).

NOTE: It is recommended that one person hold the fixture while the electrician connects the power and installs the canopy.

Install the Fixture

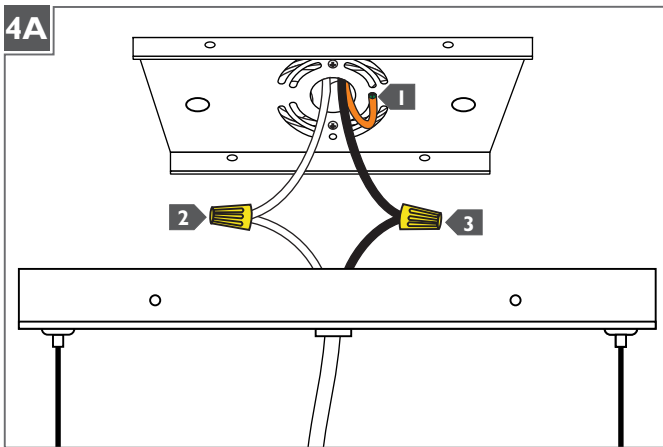

- 1 Connect the fixture to a suitable ground in accordance with local electrical codes.
- 2 Connect the white driver wire to the neutral power line wire with a wire nut.
- 3 Connect the black driver wire to the hot power line wire with a wire nut.

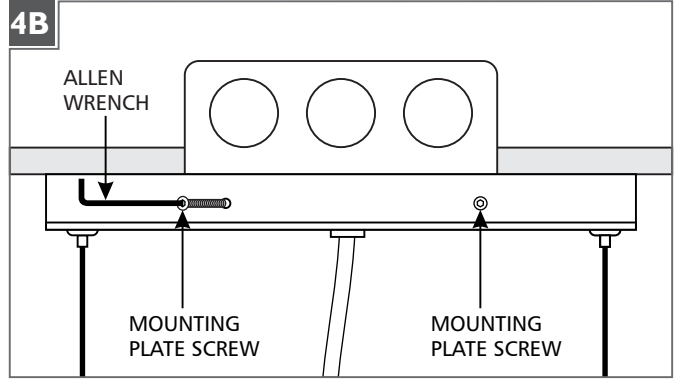

- 4 Place the driver, all wires, and wire nut connections inside the canopy.
- 5 Align the canopy holes with the mounting plate holes. Secure the canopy in place by tightening the four mounting plate screws using the Allen wrench.

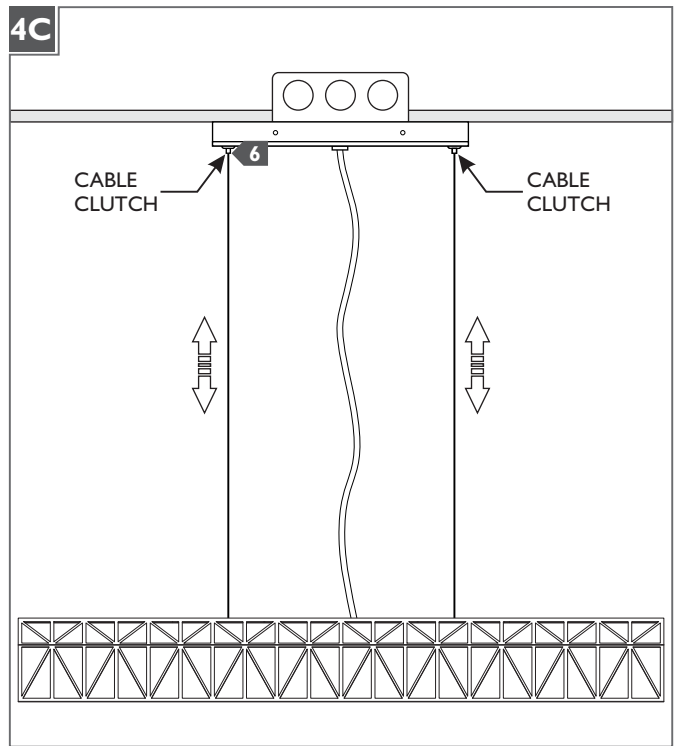

- 6 Adjust the aircraft cables until the fixture is level; feed the cable into the cable clutch to raise the fixture and push in on the cable clutch nipple to release the cable and lower the fixture.

SAVE THESE INSTRUCTIONS!

LBL

7400 Linder Ave, Skokie, IL 60077

800.323.3226 - 847.626.6300

www.lblighting.com

© 2014 LBL Lighting. All rights reserved. The "LBL Lighting" graphic is a registered trademark of LBL Lighting. LBL Lighting reserves the right to change specifications for product improvements without notification.

A Generation Brands Company