

# K-1375-H2

## FEATURES

- 72" (182.9cm) x 42" (106.7cm) x 22" (55.9cm)
- Acrylic
- 1.5 hp variable speed pump with 1.5 kW heater, and back-lit user control
- 8 Flexjets
- UL Listed
- LESS ALL TRIM

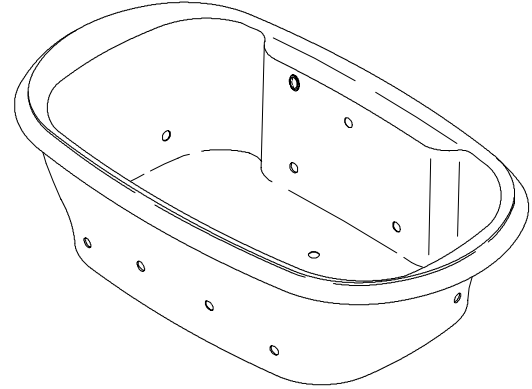

## CODES/STANDARDS APPLICABLE

Specified model meets or exceeds the following:

- ANSI Z124.1
- ASME/ANSI A112.19.7M
- IAPMO/UPC
- Underwriters Laboratories (UL)

## COLORS/FINISHES

- 0 White
- Other Refer to Price Book for additional colors

### Accessories:

- CP Polished Chrome
- PB Polished Brass
- Other Refer to Price Book for additional finishes
- NA None Applicable

## SPECIFIED MODEL:

Model	Description	Colors/Finishes		
K-1375-H2	Bath whirlpool	<input type="checkbox"/> 0 White	<input type="checkbox"/> Other_____	
<b>Required Accessories</b>				
K-9698	Jet trim kit	<input type="checkbox"/> CP	<input type="checkbox"/> PB	<input type="checkbox"/> Other_____
<b>Recommended Accessories</b>				
K-7161-AF	Drain	<input type="checkbox"/> CP	<input type="checkbox"/> PB	<input type="checkbox"/> Other_____
<b>Optional Accessories</b>				
K-1491	Pillow	<input type="checkbox"/> 0 White	<input type="checkbox"/> Other_____	
K-1601	Footstop	<input type="checkbox"/> 0 White	<input type="checkbox"/> Other_____	
K-1703	Remote control	<input type="checkbox"/> NA		

## PRODUCT SPECIFICATION:

The bath whirlpool shall be 72" (182.9cm) in length, 42" (106.7cm) in width, and 22" (55.9cm) in height. Bath whirlpool shall be made of acrylic. Bath whirlpool shall have 8 Flexjets, 1.5 hp variable speed pump, 1.5 kW heater, and back-lit user control. Bath whirlpool shall be UL listed. Bath whirlpool shall be less all trim. Bath whirlpool shall be Kohler Model K-1375-\_\_\_\_\_-\_\_\_\_\_.

## PRODUCT INFORMATION

Fixture*:	basin area	top area	weight
Bathing well	50" (127cm) x 29" (73.7cm)	61" (154.9cm) x 32" (81.3cm)	130 lbs. (59kg)
	water depth	capacity	
To overflow	16" (40.6cm)	100 gal. (378.5L)	

\* Approximate measurements for comparison only.

Pump	Heater	Voltage	Frequency	Amperage
1.5 HP	1.5 kW	240 V	50/60 Hz	11 A

## REQUIRED ELECTRICAL SERVICE

Dedicated circuit required, protected with Class A Ground-Fault Circuit-Interrupter (GFCI) or Earth-Leakage Circuit-Breaker (ELCB):

Pump/control	220/240 V, 20 A, 50/60 Hz
--------------	---------------------------

## INSTALLATION NOTES

**Note:** Pump protrusion beyond rim.

Install this product according to the installation guide.

Floor support under whirlpool must provide for a minimum of 1800 lbs. (816.5kg)

Hot water supply should be 70% of capacity or greater. Installations will vary.

If installing a rim mount faucet, make sure there is no interference with drain overflow and circulating system before drilling any holes. Consult local and national codes for minimum air gap requirements if installing a spout on the faucet deck.

No change in measurements if connected with drain illustrated. (K-7161-AF or K-7161M-AF)		
Drop-in cut-out	64" (162.6cm) x 38" (96.5cm)	
Cut-out template	113311-7	
Minimum access panel:		
Pump/control	34" (86.4cm) W x 15" (38.1cm) H	required
Faucet area		recommended

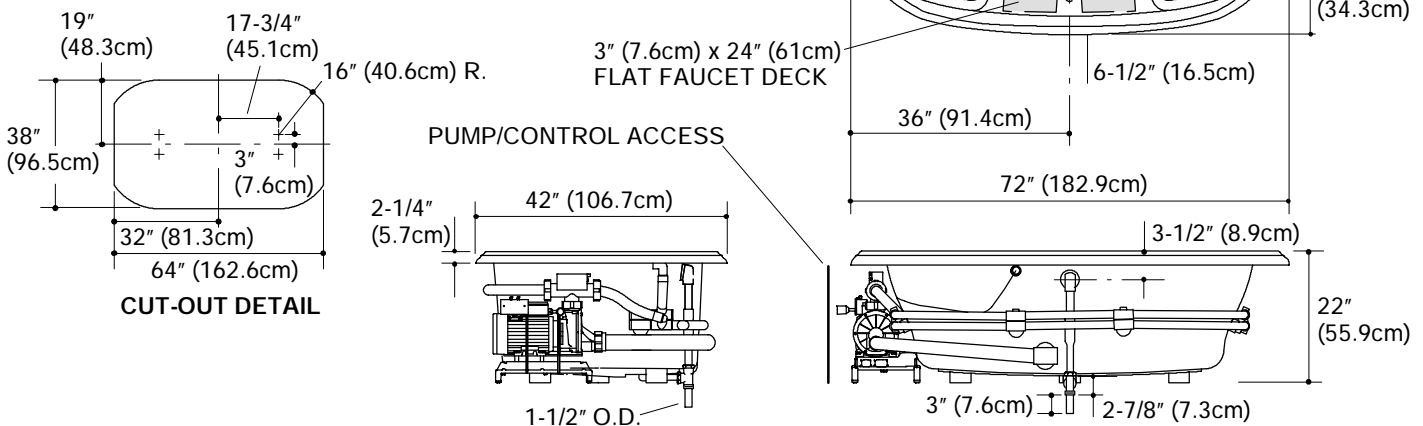

## PRODUCT DIAGRAM