



The Kohler® Advantage

- High Quality Power**
 Kohler home generators provide advanced voltage and frequency regulation along with ultra-low levels of harmonic distortion for excellent generator power quality to protect your valuable electronics.
- Extraordinary Reliability**
 Kohler is known for extraordinary reliability and performance and backs that up with a 5-year or 2000 hour limited warranty.
- Perfect for Tight Lot Lines**
 Can be placed as close as 18 inches from your home or small business, providing installation flexibility even on smaller lots. (Only applies to engine specification numbers GM88347-GA8, GM88347-GA9, or higher. Check state and local codes for minimum required distance from a structure.)
- Powerful Performance**
 Exclusive Powerboost™ technology provides excellent starting power. The Kohler 12 kW generator can easily start and run a 5 ton air conditioner with up to 5 kW pre-load.*
- Enclosure**
 Bold new Kohler design in steel, dipped in e-coat for extra corrosion protection and painted with a durable powder coat finish
- Quiet Operation**
 Kohler home generators provide quiet, neighborhood-friendly performance.

Standard Features

- RDC2 Controller**
 - One digital controller manages both the generator set and transfer switch functions (with optional Model RXT transfer switch).
 - Designed for today's most sophisticated electronics.
 - Electronic speed control responds quickly to varying household demand.
 - Digital voltage regulation protects your sensitive electronics from harmonic distortion and unstable power quality.
 - Two-line, backlit LCD display with adjustable contrast is easy to read, even in direct sunlight or low light.
 - OnCue® Plus Generator Management System for remote monitoring is included with every generator.
- Kohler Engine Features**
 - Kohler Series 7000 V-twin engine with efficient OHV design
 - Powerful, reliable air-cooled performance
 - Simple field conversion between natural gas and LPG fuels while maintaining emission certification
- Designed for Easy Installation**
 - Steel base
 - Hinged, locking roof
 - Fuel and electrical connections through the enclosure wall eliminate the need for stub-ups through the bottom
 - Accepts natural gas fuel pressure as low as 3.5 inches
 - Load connection terminal block allows easy field wiring
 - Designed for outdoor installation only
- 10RESVL and 12RESVL models packaged with a Model RXT automatic transfer switch are available. See page 4 and the Model RXT ATS specification sheet.**
- Approved for stationary standby applications in locations served by a reliable utility source**
- Meets 181 mph wind rating**
- Certifications**
 - Meets emission regulations for U.S. Environmental Protection Agency (EPA) 40 CFR 60 stationary source standards with both LPG and natural gas.
Note: CARB does not regulate emergency standby generators outputting less than 50 HP. Only the EPA standards apply.
 - UL 2200 listed (60 Hz model)
 - Accepted by the Massachusetts Board of Registration of Plumbers and Gas Fitters.

Generator Ratings

Model	Voltage	Phase	Hz	Alternator	Standby Ratings			
					Natural Gas		LPG	
					kW/kVA	Amps	kW/kVA	Amps
10RESV	120/240	1	60	2F3	9/9	37.5	10/10	41.7
12RESV	120/240	1	60	2F4	11/11	45.8	12/12	50

RATINGS: Standby ratings apply to installations served by a reliable utility source. All single-phase units are rated at 1.0 power factor. The standby rating is applicable to variable loads with an average load factor of 80% for the duration of the power outage. No overload capacity is specified at this rating. Ratings are in accordance with ISO-3046/1, BS5514, AS2789, and DIN 6271. GENERAL GUIDELINES FOR DERATING: **ALTITUDE:** Derate 4% per 305 m (1000 ft.) elevation above 153 m (500 ft.). **TEMPERATURE:** Derate 2% per 5.5°C (10°F) temperature increase above 16°C (60°F). Availability is subject to change without notice. The generator set manufacturer reserves the right to change the design or specifications without notice and without any obligation or liability whatsoever. Contact your local Kohler Co. generator distributor for availability.

* Check the appliance manufacturer's specifications for actual power requirements. Consult a Kohler® Power Systems professional to calculate your exact residential power system requirements.

Alternator Specifications

Alternator Specifications

Specifications	PowerBoost™ Generator 1-Phase
Manufacturer	Kohler
Output reconnectable	120/240
Type	2-Pole, Rotating Field
Leads, quantity	4
Voltage regulator	Digital
Insulation:	NEMA MG1-1.66
Material	Class H
Temperature rise	Class H
Bearing: quantity, type	1, Sealed Ball
Coupling	Direct
Amortisseur windings	Full
Voltage regulation, no-load to full-load RMS	± 1.0%
One-step load acceptance	100% of Rating
Peak motor starting kVA:	(35% dip for voltages below)
240 V, 2F3 (60 Hz)	16.8
240 V, 2F4 (60 Hz)	20.3

Alternator Features

- Compliance with NEMA, IEEE, and ANSI standards for temperature rise
- Self-ventilated and drip-proof construction
- Windings are vacuum-impregnated with epoxy varnish for dependability and long life.
- Superior voltage waveform and minimum harmonic distortion from skewed alternator construction
- Digital voltage regulator with ±1.0% no-load to full-load RMS regulation
- Rotating-field alternator with static exciter for excellent load response
- Total harmonic distortion (THD) from no load to full load with a linear load is less than 5%.

Application Data

Engine

Engine Specifications	10RESV	12RESV
Manufacturer	Kohler	
Engine: model, type	KT725	
Cylinder arrangement	V-2	
Displacement, cm ³ (cu. in.)	725 (44)	
Bore and stroke, mm (in.)	83 x 67 (3.3 x 2.6)	
Compression ratio	9.0:1	
Main bearings: quantity, type	2, Parent Material	
Rated RPM	3600	
60 Hz	3600	
Max. engine power at rated rpm, kW (HP)		
LPG, 60 Hz	16 (21.4)	
Natural gas, 60 Hz	13.4 (18)	
Cylinder head material	Aluminum	
Valve material	Steel/Stellite®	
Piston type and material	Aluminum Alloy	
Crankshaft material	Heat Treated, Ductile Iron	
Governor: type	Electronic	
Frequency regulation, no load to full load	Isochronous	
Frequency regulation, steady state	±1.0%	
Air cleaner type	Dry	

Exhaust

Exhaust System	10RESV	12RESV
Exhaust temperature exiting the enclosure at rated kW, dry, °C (°F)	106 (224)	106 (224)

Engine Electrical

Engine Electrical System	10RESV	12RESV
Ignition system	Electronic, Capacitive Discharge	
Starter motor rated voltage (DC)	12	
Battery (purchased separately):		
Ground	Negative	
Volts (DC)	12	
Battery quantity	1	
Recommended cold cranking amps: (CCA) rating for - 18°C (0°F)	500	
Group size	51	

Lubrication

Lubricating System	10RESV	12RESV
Type	Full Pressure	
Oil capacity (with filter), L (qt.) *	1.9 (2.0)	
Oil filter: quantity, type	1, Cartridge	

* Oil capacity for a new, dry engine.

Fuel Pipe Size

Pipe Length, m (ft.)	10RESV		12RESV	
	Natural Gas	LPG	Natural Gas	LPG
8 (25)	179,000 Btu/hr.	222,500 Btu/hr.	216,000 Btu/hr.	257,500 Btu/hr.
15 (50)	3/4	3/4	3/4	3/4
30 (100)	1	3/4	1	1
46 (150)	1	1	1-1/4	1
61 (200)	1 1/4	1	1-1/4	1 1/4
	1 1/4	1 1/4	1 1/4	1 1/4

Fuel Requirements

Fuel System	10RESV	12RESV
Fuel types	Natural Gas or LPG	
Fuel supply inlet	1/2 NPT	
Fuel supply pressure, kPa (in. H ₂ O):		
Natural gas	.87- 2.7 (3.5-11)	
LP	1.7- 2.7 (7-11)	

Fuel Composition Limits *	Nat. Gas	LPG
Methane, % by volume (minimum)	90 min.	—
Ethane, % by volume (maximum)	4.0 max.	—
Propane, % by volume	1.0 max.	85 min.
Propene, % by volume (maximum)	0.1 max.	5.0 max.
C ₄ and higher, % by volume	0.3 max.	2.5 max.
Sulfur, ppm mass (maximum)	25 max.	
Lower heating value, MJ/m ³ (Btu/ft ³), (minimum)	33.2 (890)	84.2 (2260)

* Contact your local distributor for suitability and rating derates based on fuel compositions outside these limits.

Operation Requirements

Fuel Consumption			
Model	Fuel Type	% Load	Fuel Consumption, m ³ /hr. (cfh)
10RESV	Natural Gas	100	5.1 (179)
		75	4.1 (145)
		50	3.4 (120)
		25	2.7 (97)
		Exercise	2.1 (75)
	LPG	100	2.5 (89)
		75	2.0 (69)
		50	1.5 (52)
		25	1.1 (39)
		Exercise	0.8 (29)
12RESV	Natural Gas	100	6.1 (216)
		75	4.5 (160)
		50	3.6 (128)
		25	2.8 (99)
		Exercise	2.1 (74)
	LPG	100	2.9 (103)
		75	2.2 (76)
		50	1.6 (57)
		25	1.2 (42)
		Exercise	0.8 (30)
Nominal fuel rating: Natural gas:		37 MJ/m ³ (1000 Btu/ft. ³)	
LPG:		93 MJ/m ³ (2500 Btu/ft. ³)	
LPG conversion factors:		8.58 ft. ³ = 1 lb.	
		0.535 m ³ = 1 kg	
		36.39 ft. ³ = 1 gal.	

Sound Data

Model 10RESV and 12RESV 8 point logarithmic average sound levels are 67 dB(A) during weekly engine exercise and 71 dB(A) during full-speed generator diagnostics and normal operation. For comparison to competitor ratings, the lowest point sound levels are 64 dB(A) and 69 dB(A) respectively.*

All sound levels are measured at 7 meters with no load.

* Lowest of 8 points measured around the generator. Sound levels at other points around generator may vary depending on installation parameters.

RDC2 Controller

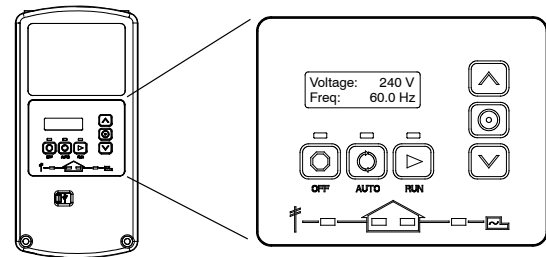

The RDC2 controller provides integrated control for the generator set, Kohler® Model RXT transfer switch, programmable interface module (PIM), and load management device.

The RDC2 controller's 2-line LCD screen displays status messages and system settings that are clear and easy to read, even in direct sunlight or low light.

RDC2 Controller Features

- Membrane keypad
 - OFF, AUTO, and RUN pushbuttons
 - Select and arrow buttons for access to system configuration and adjustment menus
- LED indicators for OFF, AUTO, and RUN modes
- LED indicators for utility power and generator set source availability and ATS position (Model RXT transfer switch required)
- LCD display
 - Two lines x 16 characters per line
 - Backlit display with adjustable contrast for excellent visibility in all lighting conditions
- Scrolling system status display
 - Generator set status
 - Voltage and frequency
 - Engine temperature
 - Oil pressure
 - Battery voltage
 - Engine runtime hours
- Date and time displays
- Smart engine cooldown senses engine temperature
- Digital isochronous governor to maintain steady-state speed at all loads
- Digital voltage regulation: ± 1.0% RMS no-load to full-load
- Automatic start with programmed cranking cycle
- Programmable exerciser can be set to start automatically on any future day and time, and run every week or every two weeks
- Exercise modes
 - Unloaded weekly exercise with complete system diagnostics
 - Unloaded full-speed exercise
 - Loaded full-speed exercise (Model RXT ATS required)
- Front-access mini USB connector for SiteTech™ or USB Utility connection
- Integral Ethernet connector for Kohler® OnCue® Plus
- Built-in 2.5 amp battery charger
- Remote two-wire start/stop capability for optional connection of Model RDT transfer switches

See additional controller features on the next page.

Additional RDC2 Controller Features

- Diagnostic messages
 - Displays diagnostic messages for the engine, generator, Model RXT transfer switch, programmable interface module (PIM), and load management
 - Over 70 diagnostic messages can be displayed
- Maintenance reminders
- System settings
 - System voltage, frequency, and phase
 - Voltage adjustment
 - Measurement system, English or metric
- ATS status (Model RXT ATS required)
 - Source availability
 - ATS position (normal/utility or emergency/generator)
 - Source voltage and frequency
- ATS control (Model RXT ATS required)
 - Source voltage and frequency settings
 - Engine start time delay
 - Transfer time delays
 - Voltage calibration
 - Fixed pickup and dropout settings
- Programmable Interface Module (PIM) status displays
 - Input status (active/inactive)
 - Output status (active/inactive)
- Load control menus

Generator Set Standard Features

- Battery cables
- Critical silencer
- EPA certified fuel system
- Field-connection terminal block
- Fuel solenoid valve and secondary regulator
- Line circuit breaker:
 - 10RESV: 50 amps
 - 12RESV: 60 amps
- Multi-fuel system, LPG/natural gas, field-convertible
- Oil drain extension with shutoff valve
- OnCue® Plus Generator Management System
- RDC2 generator set/ATS controller
- Rodent-resistant construction
- Sound enclosure with sound-deadening, flame-retardant foam per UL 94, class HF-1
- 5-year limited warranty

Available Accessories

Approvals and Listings

- CSA Approval (60 Hz only)

Concrete Mounting Pads

- Concrete mounting pad, 3 in. thick
- Concrete mounting pad, 4 in. thick (recommended for storm-prone areas)

Electrical System

- Battery

Fuel System

- Flexible fuel line

Available Accessories, Continued

Controller Accessories

- Programmable Interface Module (PIM) (provides 2 digital inputs and 6 relay outputs)
- Load shed kit
- Power relay modules (use up to 4 modules for each load management device)

Maintenance

- Maintenance kit

Literature

- General maintenance literature kit
- Overhaul literature kit
- Production literature kit

Starting Aids

- Carburetor heater, 120 VAC (recommended for reliable starting at temperatures below 0°C [32°F])

Kohler® Automatic Transfer Switch

- Model RXT, see specification sheet G11-121
- Model RDT, see specification sheet G11-98
- Model RXT with combined interface/load management board
- Other Kohler® ATS

10/12RESVL Model Packages

- 10RESVL with 100 amp RXT with 12-space load center and NEMA 1 steel enclosure for indoor installation
- 12RESVL with 100 amp RXT with 12-space load center and NEMA 1 steel enclosure for indoor installation

* Accessories are available through Kohler authorized distributors and dealers.

Generator Set Dimensions and Weights

Overall Size, L x W x H: 777 x 712 x 824 mm (30.6 x 28 x 32.4 in.)

Shipping Weight:

10RESV Generator Set	194 kg (428 lb.)
12RESV Generator Set	196 kg (433 lb.)
10RESVL w/ATS	203 kg (448 lb.)
12RESVL w/ATS	205 kg (453 lb.)

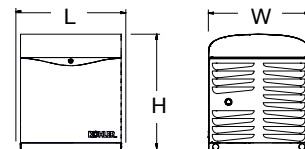

NOTE: Dimensions are provided for reference only and should not be used for planning installation. Contact your local distributor for more detailed information.

DISTRIBUTED BY:

Residential/Light Commercial Generator Accessories

KOHLER Power Systems

Concrete Mounting Pads

ISO 9001
KOHLER
POWER SYSTEMS
NATIONALLY REGISTERED



Models 8/10/12RESV/RESVL



Models 14/20RESA/RESAL, 20RESC/RESCL



Applicable Models

- 8RESV/RESVL
- 10RESV/RESVL
- 12RESV/RESVL
- 14RESA/RESAL
- 20RESA/RESAL
- 20RESC/RESCL

Description

Concrete mounting pads allow easy installation of the Kohler® residential generator models listed above. Mounting pads are available in 3 inch and 4 inch thicknesses. The 4-inch hurricane pad has a wind rating of 175 mph and is recommended for storm-prone areas.

- Fiber-reinforced concrete pad with rebar.
- Impact resistant.
- Flat bottom facilitates mounting and leveling of the generator and prevents the generator from sinking into the ground.
- Pad is sized and contoured for the generator models listed above.
- 3/8-16 threaded inserts are located at the generator mounting hole positions for easy installation.
- Pad contains 25% recycled materials.

Specifications

Specification	GM92228-KP1-QS 8/10/12RESV(L)	GM92228-KP2-QS 8/10/12RESV(L)	GM90969-KP1-QS 14/20RESA(L) 20RESC(L)	GM90969-KP2-QS 14/20RESA(L) 20RESC(L)
Dimensions, pallet of 10 (L x W x H)	940 mm x 864 mm x 1118 mm (37 in. x 34 in. x 44 in.)	945 mm x 869 mm x 1372 mm (37.2 in. x 34.2 in. x 54 in.)	1372 mm x 787 mm x 1118 mm (54 in. x 31 in. x 44 in.)	1372 mm x 787 mm x 1372 mm (54 in. x 31 in. x 54 in.)
Weight, pallet of 10	658 kg (1450 lbs.)	885 kg (1950 lbs.)	907 kg (2000 lbs.)	1293 kg (2850 lbs.)
Purchase quantity	10	10	10	10

Individual Pad Specification	GM92226 8/10/12RESV(L)	GM92227 8/10/12RESV(L)	GM90969 14/20RESA(L) 20RESC(L)	GM90970 14/20RESA(L) 20RESC(L)
Dimensions (L x W x H)	940 mm x 864 mm x 76 mm (37 in. x 34 in. x 3 in.)	945 mm x 869 mm x 102 mm (37.2 in. x 34.2 in. x 4 in.)	1372 mm x 787 mm x 76 mm (54 in. x 31 in. x 3 in.)	1372 mm x 787 mm x 102 mm (54 in. x 31 in. x 4 in.)
Thickness	76 mm (3 in.)	102 mm (4 in.)	76 mm (3 in.)	102 mm (4 in.)
Weight, each	61 kg (135 lbs.)	84 kg (185 lbs.)	86 kg (190 lbs.)	125 kg (275 lbs.)
Wind rating	NA	175 mph	NA	175 mph

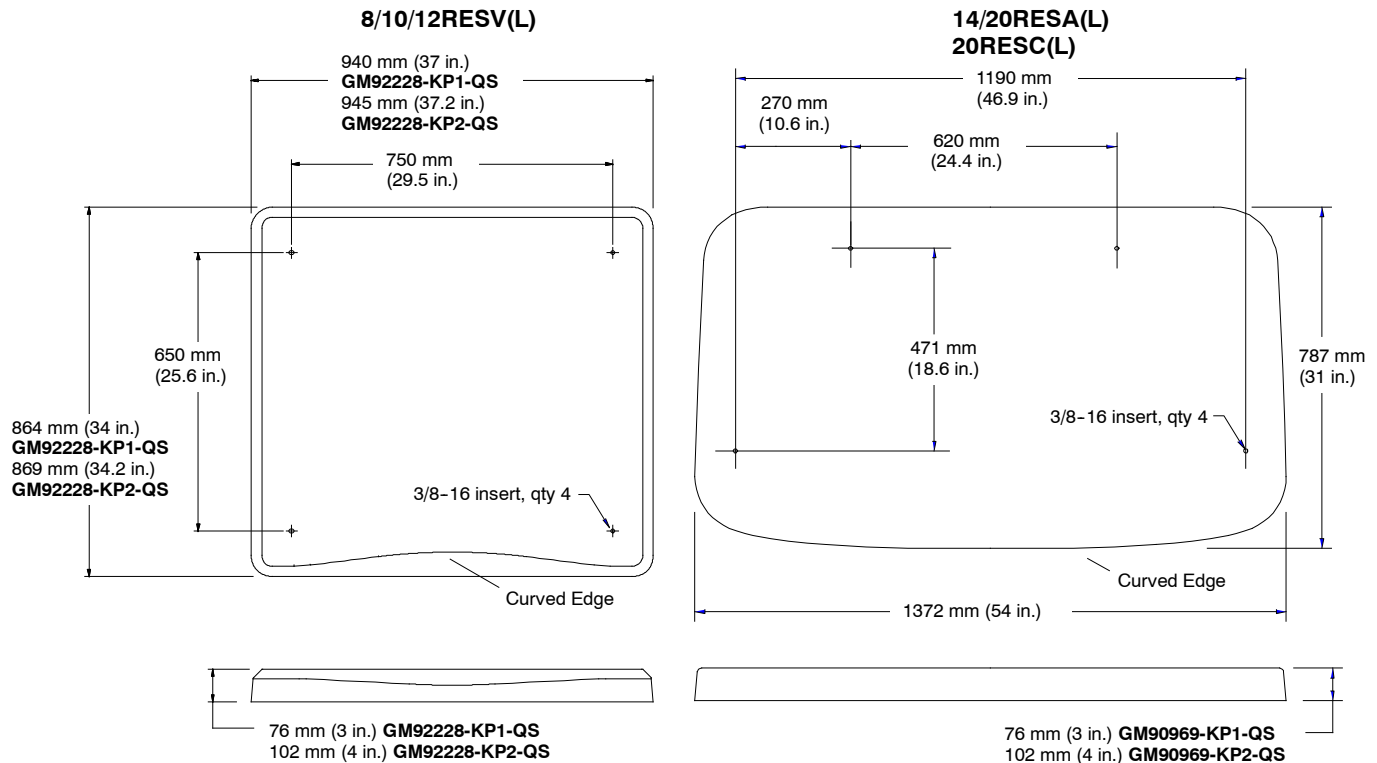

DISTRIBUTED BY:

Availability is subject to change without notice. Kohler Co. reserves the right to change the design or specifications without notice and without any obligation or liability whatsoever. Contact your local Kohler® generator distributor for availability.

© 2014, 2015 by Kohler Co. All rights reserved.

Residential/Light Commercial Generator Accessories



Kohler® OnCue® Plus Generator Management System

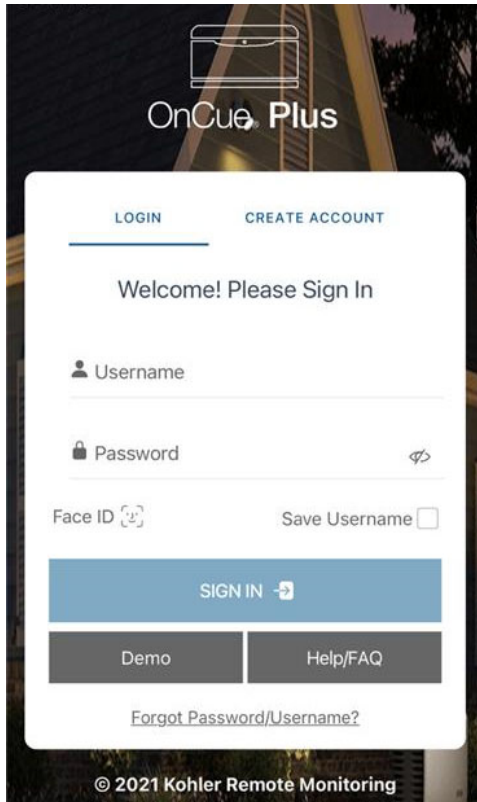

OnCue® Plus is a remote monitoring application that is included with Residential and Light Commercial generators equipped with the controllers listed below. It allows you to access your generator from a computer or smart device anytime, anywhere. You can easily monitor and control your generator set using this application.

Applicable Models

OnCue Plus can be used with Kohler Residential and Light Commercial generator sets equipped with the following controllers:

- RDC2 or DC2 Controller
- RDC or DC Controller
- VSC Controller (6VSG variable-speed DC generator set)

The optional OnCue Plus wireless kit is available for generator sets equipped with the following controllers:

- RDC2 or DC2 Controller
- VSC Controller (6VSG variable-speed DC generator set)

OnCue Plus Features

- Simple activation, required just once for each generator.
- Monitor your complete Kohler power system, including the generator, RXT automatic transfer switch, Load Control Module (LCM)*, and Programmable Interface Module (PIM)†.
- Control home automation when the generator set is paired with a Programmable Interface Module (PIM)†. Remote control features:
 - Remotely turn appliances, outdoor lighting, storm shutters, or other electrical equipment on or off.
 - The generator does not need to be running in order to use OnCue Plus for remote control of circuits connected to the PIM.
- Monitor total generator power and percent of generator's rated power on models equipped with a model RXT transfer switch and load shed accessory. *
- Monitor multiple generator sets on one account.
- View time- and date-stamped event history listing generator set starting and stopping, faults, and notifications. (RDC2)
- Receive generator alerts by email, text message, or push notifications on your mobile device or PC. Customize messages by selecting the events that will prompt a notification to be sent to each recipient.
- Start and stop generator exercises from your computer or mobile device, or using the OnCue Plus action/skill on Google Assistant or Amazon Alexa.
- Controller password and generator set serial number protect against access by unauthorized users.

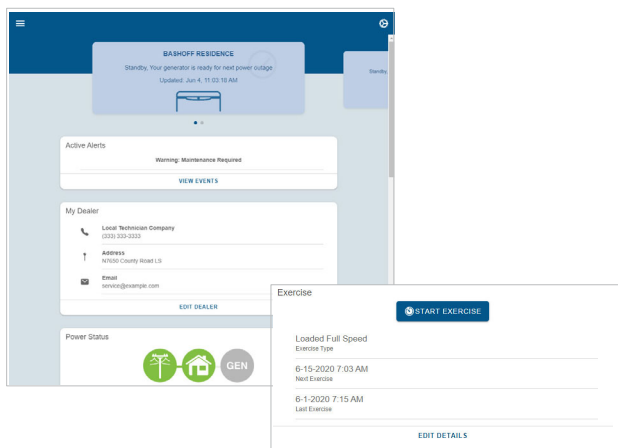

Apple, the Apple logo, iPhone and iPad are registered trademarks of Apple Inc., registered in the U.S. and other countries. App Store is a service mark of Apple Inc.

Alexa and all related marks are trademarks of Amazon.com, Inc or its affiliates.

Android, Google and Google Play are trademarks of Google LLC.

* Model RXT automatic transfer switch and LCM can be used with generator sets equipped with the RDC2 or DC2 controller.

† PIM can be used with generator sets equipped with the RDC2, DC2, or VSC controller.

Note: Views shown in this document are samples. Actual views may vary based on customer application and OnCue Plus program updates.

Typical Connections (using cables)

Residential/Light Commercial Generator Set with RDC2 or DC2 Controller

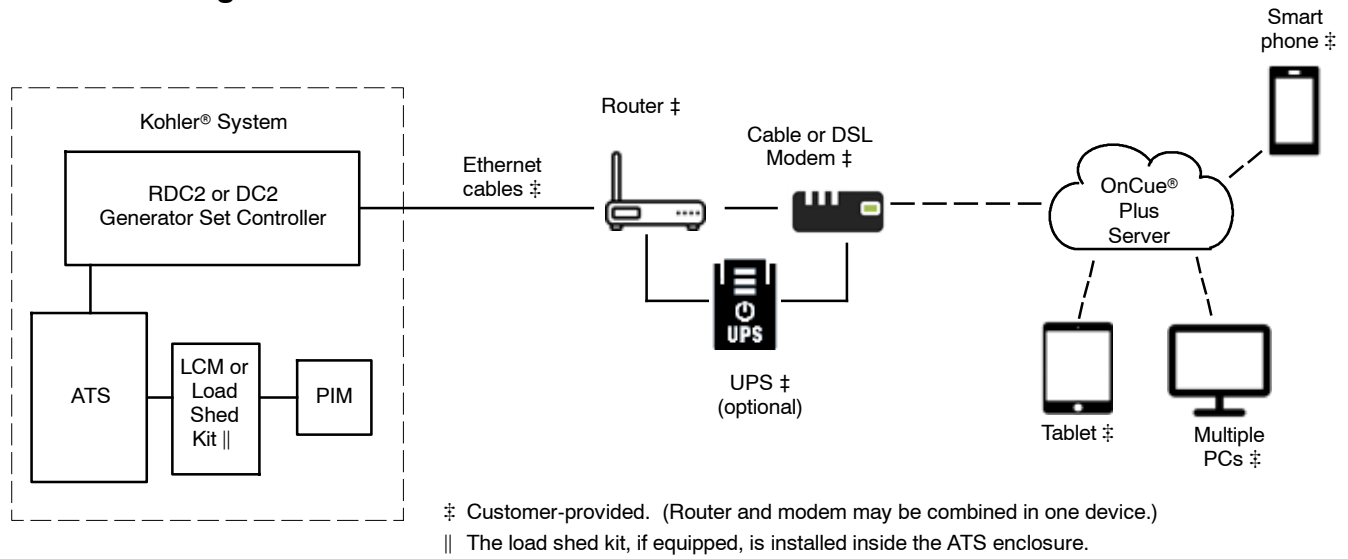

Model VSG Generator set with VSC Controller

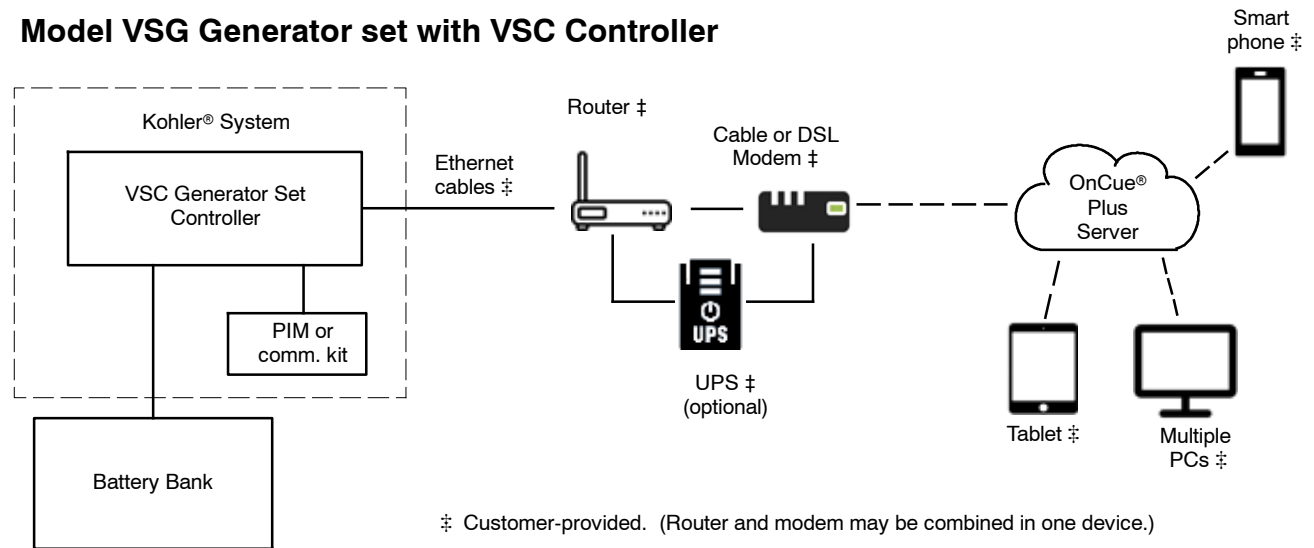

Typical Connections (using wireless kit)

Residential/Light Commercial Generator Set with RDC2 or DC2 Controller

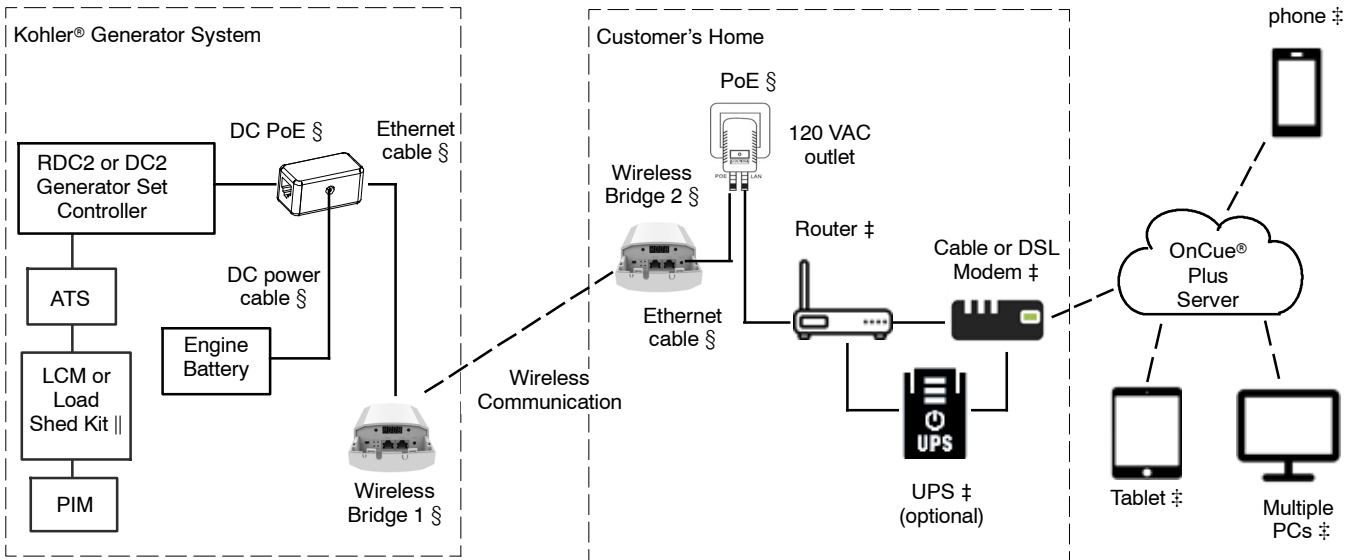

‡ Customer-provided. (Router and modem may be combined in one device.)

§ Provided in the Kohler wireless kit. (Two Ethernet cables for connecting the bridge to the Power over Ethernet [PoE] ports are provided.)

|| The load shed kit, if equipped, is installed inside the ATS enclosure.

Model VSG Generator Set with VSC Controller

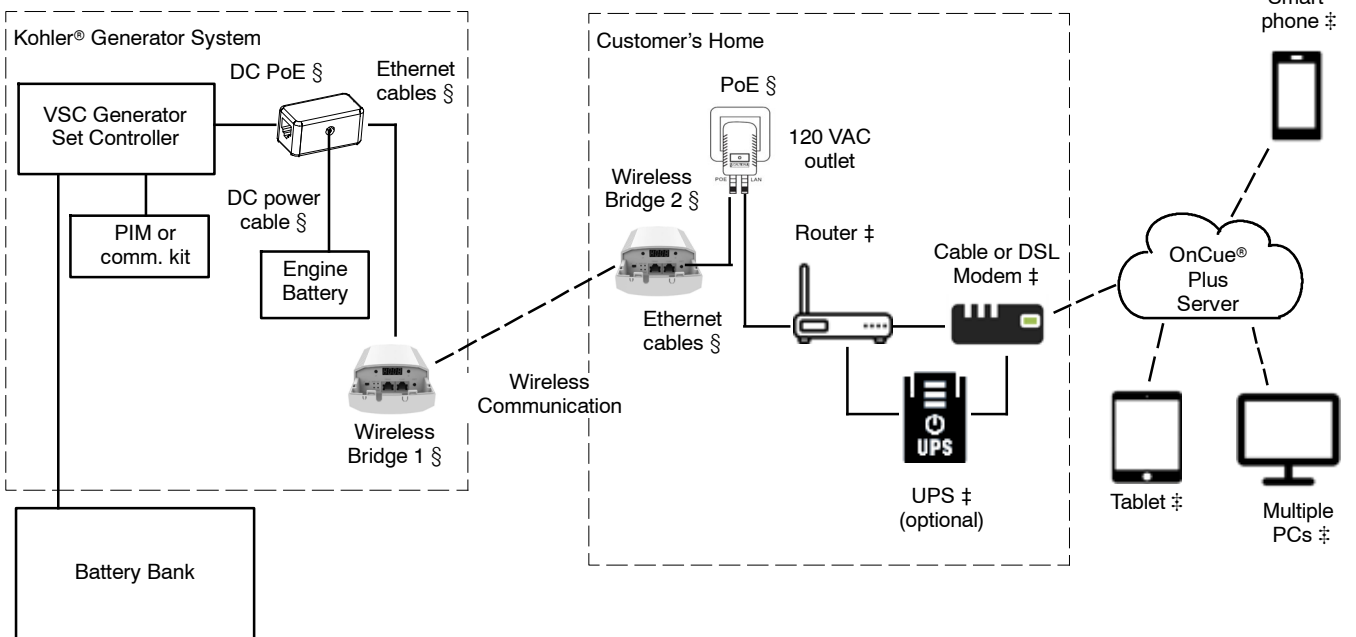

‡ Customer-provided. (Router and modem may be combined in one device.)

§ Provided in the Kohler wireless kit. (Two Ethernet cables for connecting the bridge to the Power over Ethernet [PoE] ports are provided.)

System Requirements

- Personal computer (PC) requires one of these Internet browsers:
 - Google Chrome
 - Apple Safari
 - Microsoft Edge 79+
 - Firefox
- Mobile devices require Android™ 5.0 or higher or iOS 11.0 or higher
- Always-on Internet access for the generator (for example, cable, DSL, or phone line modem connected 24 hours a day)
- Amazon Alexa or Google Assistant application on smart devices to access voice control (optional)
- OnCue Plus wireless kit (optional)
- Uninterruptible power supply (UPS) for modem and router (optional)
- See the connection diagrams for customer-provided cables and equipment

Wireless Bridge Specifications

- Environmental specifications:
 - Operating temperature: -30 to 55°C (-22 to 131°F)
 - Storage temperature: -40 to 70°C (-40 to 158°F)
 - Humidity: 5% to 95% (typical)
 - Waterproof level IP65
- Dimensions. L x W x H: 168 x 88 x 48 mm (6.6 x 3.5 x 1.9 in.)
- RF Frequency: 5.150-5.850 GHz
- Regulatory Compliance:
 - CE-LVD
 - EN 60950-1:2006 + A1: 2009 + A1: 2010 + A12: 2011 + A2: 2013
 - IEC 60950-1: 2005 + A1: 2009 + A2: 2013
- Protocol/Standard
 - IEEE 802.3 (Ethernet)
 - IEEE 802.3u (Fast Ethernet)
 - IEEE 802.11b/g/n/ac
- Power Specification:
 - DC PoE: 24 VDC @ 0.5A
- Wireless Bridge Operating Specifications:
 - Voltage 100-240 VAC
 - Frequency 50-60 Hz
 - Input current 300 mA max. @ 90 VAC min.
- LEDs for power and network connection status

View System Operation Data

Generator Set

- Home is powered by the generator or utility power
- Generator set status: running, standby, shutdown, or off
- Active fault indication
- Generator voltage
- Engine starting battery voltage, VDC
- Frequency, Hz
- Generator event history
- Event details, including description, time, and date
- Exercise type
- Next scheduled exercise date and time (estimated based on last exercise date and time)
- Over 20 different parameters
- Generator power, in kW (LCM required*)
- Engine hours
- Last exercise date and time
- Exercise interval, duration and mode

Load Management *

- Loads are added or shed automatically based on generator load
- View connected loads
- On/Off indicators for each circuit indicate status (powered or shed)
- Change load labels to identify the connected circuits

Programmable Interface Module (PIM) †

- View relay status
- On/Off indicators show connected circuits
- Change input and output labels to identify connected circuits

6VSG Communications Kit

- View input and output status
- On/Off indicators show connected circuits

* Model RXT automatic transfer switch and Load Control Module (LCM), load shed kit, or combined interface/load management board can be used with generator sets equipped with the RDC2 or DC2 controller.

† PIM can be used with generator sets equipped with the RDC2, DC2, or VSC controller.

Voice Activation

- Use Google Assistant or Amazon Alexa to control your generator by using your voice.
- Easy setup:
 - Confirm the setup of your OnCue Plus account.
 - Search for OnCue Plus action/skill on the Google Assistant or Amazon Alexa app and follow the simple step-by-step guide to link the accounts.
 - Start talking to your Kohler generator(s) by saying, "Hey Google, ask OnCue Plus," or "Alexa, ask OnCue Plus."
- Sample voice commands:
 - What is the status of my generator?
 - Does my generator have any active alerts?
 - What's the battery voltage?
 - What's the oil temperature?
 - What's the engine temperature?
 - When was my last exercise?
 - Start an exercise.
 - Stop an exercise.
 - Change my exercise details.

Notifications

Email, text messages, and push notifications are sent for the following events. Notifications for selected events can be turned off or on for different recipients. Push notifications can be turned on or off using a smart phone or tablet, and then viewed on a smart phone, tablet, or personal computer.

- Exercise Start
- Exercise Ended
- Generator Running
- Generator Stopped
- Generator Not in Auto/ In Auto
- Utility Loss/ Restored
- Communication Loss/ Restored
- Warnings Active/Cleared (includes maintenance reminders)
- Shutdowns Active/Reset

Remote Control/Home Automation

Generator Set

- Start/stop exercises remotely
- Manage exercise interval, duration and mode

Programmable Interface Module (PIM)‡

- Allows remote control of appliances and other electrical devices in your home
- Use your PC or mobile device to turn your lights or appliances on and off from any location with Internet access
- The generator does not need to be running in order to use OnCue Plus for remote control of circuits connected to the PIM.

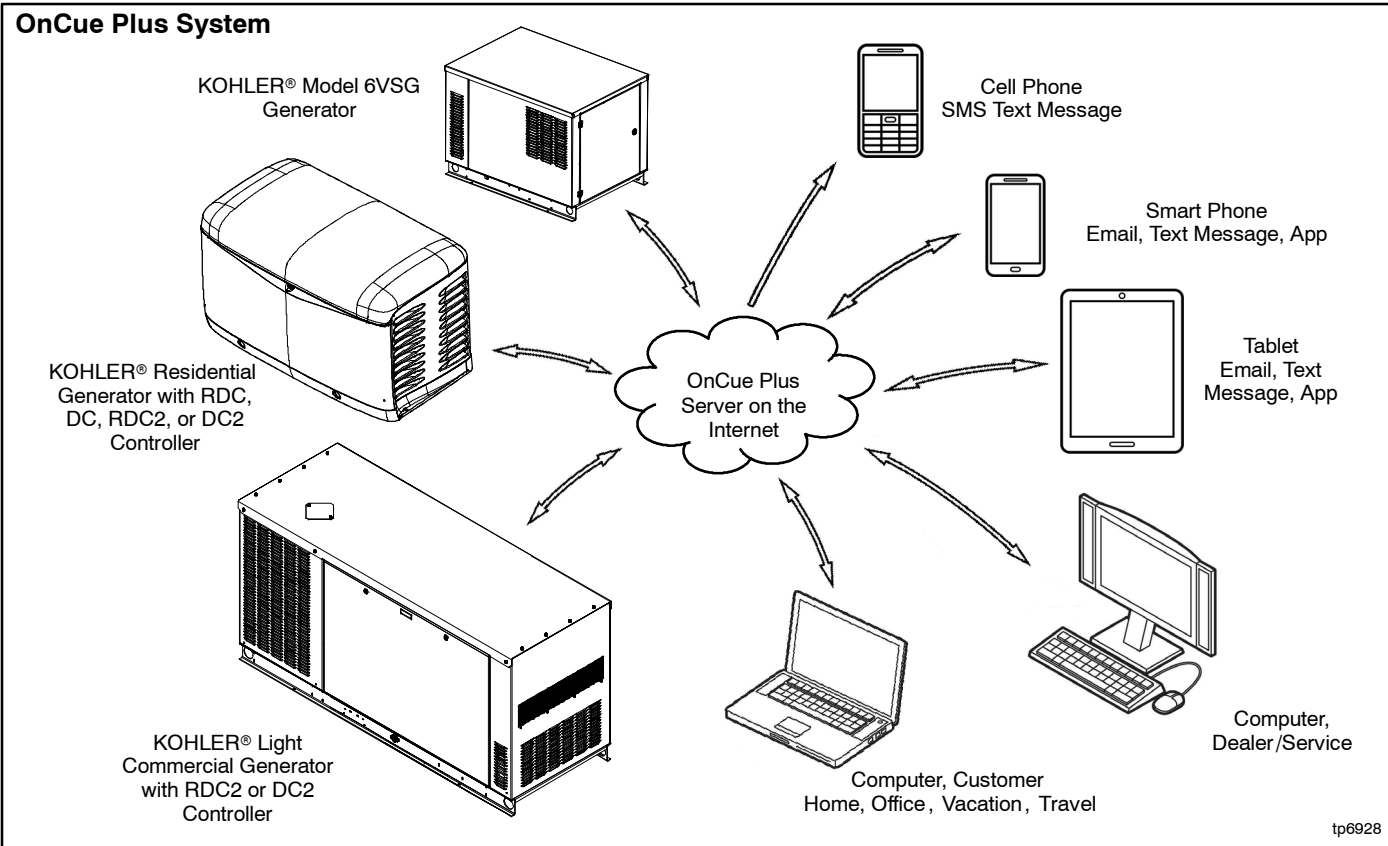

OnCue® Plus System Kit

Included with every Residential and Light Commercial generator set that is equipped with the RDC2 or VSG controller.

- Activation code decal
- Ethernet connector
- User manual
- Technical Manual

OnCue® Plus Wireless Kit

Optional kit provides wireless connectivity between the generator controller and the homeowner's router.

- Wireless bridges (quantity 2)
- AC power over Ethernet port
- DC power over Ethernet port
- DC power cable
- Ethernet cables (quantity 2 for power over Ethernet connection to wireless bridges)
- Installation instructions with connection diagrams

DISTRIBUTED BY:

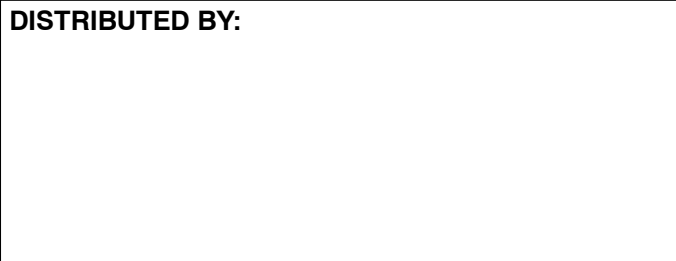

Availability is subject to change without notice. Kohler Co. reserves the right to change the design or specifications without notice and without any obligation or liability whatsoever. Contact your local Kohler® generator distributor for availability.

© 2021 Kohler Co. All rights reserved.