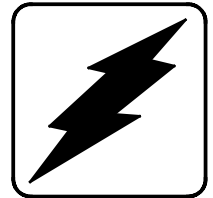


# Operation

## Residential/Commercial Generator Sets



Models:

**12RES**

Similar Models (no longer available):

**8.5/17/18RES**

**12/18TRES**

Controller:

Advanced Digital Control ADC-RES

**KOHLER®**

TP-6515 2/21g

**⚠ WARNING:** This product can expose you to chemicals, including carbon monoxide and benzene, which are known to the State of California to cause cancer and birth defects or other reproductive harm. For more information go to [www.P65warnings.ca.gov](http://www.P65warnings.ca.gov)

## Product Identification Information

---

Product identification numbers determine service parts. Record the product identification numbers in the spaces below immediately after unpacking the products so that the numbers are readily available for future reference. Record field-installed kit numbers after installing the kits.

### Generator Set Identification Numbers

Record the product identification numbers from the generator set nameplate(s).

Model Designation \_\_\_\_\_  
Specification Number \_\_\_\_\_  
Serial Number \_\_\_\_\_

| Accessory Number | Accessory Description |
|------------------|-----------------------|
| _____            | _____                 |
| _____            | _____                 |
| _____            | _____                 |
| _____            | _____                 |
| _____            | _____                 |
| _____            | _____                 |
| _____            | _____                 |
| _____            | _____                 |
| _____            | _____                 |
| _____            | _____                 |
| _____            | _____                 |
| _____            | _____                 |
| _____            | _____                 |
| _____            | _____                 |
| _____            | _____                 |
| _____            | _____                 |
| _____            | _____                 |
| _____            | _____                 |
| _____            | _____                 |
| _____            | _____                 |
| _____            | _____                 |
| _____            | _____                 |
| _____            | _____                 |

### Controller Identification

Record the controller description from the generator set operation manual, spec sheet, or sales invoice.

Controller Description \_\_\_\_\_

### Engine Identification

Record the product identification information from the engine nameplate.

Manufacturer \_\_\_\_\_  
Model Designation \_\_\_\_\_  
Serial Number \_\_\_\_\_

# Table of Contents

|   |           |
|---|-----------|
| <b>Product Identification Information</b> .....         | <b>2</b>  |
| <b>Safety Precautions and Instructions</b> .....        | <b>5</b>  |
| <b>Introduction</b> .....                               | <b>9</b>  |
| <b>Service Assistance</b> .....                         | <b>11</b> |
| <b>Section 1 Specifications</b> .....                   | <b>13</b> |
| 1.1 Introduction .....                                  | 13        |
| 1.2 Generator .....                                     | 13        |
| 1.3 Engine .....  | 13        |
| 1.4 Advanced Digital Control .....                      | 13        |
| 1.5 Accessories .....                                   | 14        |
| 1.5.1 Carburetor Heater .....                           | 14        |
| 1.5.2 Battery Heater Kit .....                          | 14        |
| 1.6 Service Views for Maintenance .....                 | 15        |
| <b>Section 2 Operation</b> .....                        | <b>19</b> |
| 2.1 Operating Area .....                                | 19        |
| 2.2 Prestart Checklist .....                            | 19        |
| 2.3 Exercising Generator Set .....                      | 20        |
| 2.4 ADC-RES Controls and Indicators .....               | 20        |
| 2.4.1 LED Display .....                                 | 20        |
| 2.4.2 Controller Keypad .....                           | 21        |
| 2.4.3 Generator Set Master Switch .....                 | 21        |
| 2.5 Controller Power .....                              | 22        |
| 2.5.1 Standby Mode .....                                | 22        |
| 2.5.2 Sleep Mode .....                                  | 22        |
| 2.6 Generator Set Operation .....                       | 22        |
| 2.6.1 Starting Generator Set .....                      | 22        |
| 2.6.2 Stopping Generator Set .....                      | 22        |
| 2.6.3 Emergency Stopping (TRES Models Only) .....       | 23        |
| 2.7 Faults .....  | 24        |
| 2.7.1 Shutdowns .....                                   | 24        |
| 2.7.2 Warnings .....                                    | 24        |
| 2.7.3 Resetting Controller after a Fault Shutdown ..... | 24        |
| 2.8 Battery Charger .....                               | 26        |
| 2.8.1 RES Battery Charger .....                         | 26        |
| 2.8.2 TRES Battery Charger .....                        | 27        |
| <b>Section 3 Scheduled Maintenance</b> .....            | <b>29</b> |
| 3.1 Scheduled Maintenance .....                         | 29        |
| 3.1.1 Service Schedule, 8.5/12 kW Models .....          | 30        |
| 3.1.2 Service Schedule, 17/18 kW Models .....           | 31        |
| 3.2 Lubrication System .....                            | 32        |
| 3.2.1 Low Oil Pressure Shutdown .....                   | 32        |
| 3.2.2 Oil Check .....                                   | 32        |
| 3.2.3 Engine Oil Recommendation .....                   | 32        |
| 3.2.4 Oil Change Procedure .....                        | 32        |
| 3.2.5 Oil Cooler, 17/18 kW .....                        | 33        |
| 3.3 Spark Plugs .....                                   | 34        |
| 3.4 Air Cleaner Service .....                           | 34        |
| 3.4.1 Air Cleaner, 8.5/12RES .....                      | 34        |
| 3.4.2 Air Cleaner, 17/18RES .....                       | 35        |
| 3.5 Cooling System .....                                | 36        |
| 3.6 Exhaust System .....                                | 36        |
| 3.7 Battery .....                                       | 37        |

# Table of Contents, continued

---

|  |                                       |           |
|--|---------------------------------------|-----------|
| 3.8                                    | Battery Charger .....                 | 37        |
| 3.9                                    | Circuit Protection .....              | 38        |
| 3.9.1                                  | Line Circuit Breaker .....            | 38        |
| 3.9.2                                  | Fuses .....                           | 38        |
| 3.10                                   | Storage Procedure .....               | 39        |
| 3.10.1                                 | Lubricating System .....              | 39        |
| 3.10.2                                 | Fuel System .....                     | 39        |
| 3.10.3                                 | Cylinder Lubrication .....            | 39        |
| 3.10.4                                 | Exterior Preparation .....            | 39        |
| 3.10.5                                 | Battery .....                         | 39        |
| <b>Section 4 Troubleshooting .....</b> |                                       | <b>41</b> |
| 4.1                                    | Introduction .....                    | 41        |
| 4.2                                    | Controller Troubleshooting .....      | 41        |
| 4.3                                    | Generator Set Troubleshooting .....   | 41        |
| 4.4                                    | Battery Charger Troubleshooting ..... | 43        |
| <b>Appendix A Abbreviations .....</b>  |                                       | <b>45</b> |

# Safety Precautions and Instructions

**IMPORTANT SAFETY INSTRUCTIONS.** Electromechanical equipment, including generator sets, transfer switches, switchgear, and accessories, can cause bodily harm and pose life-threatening danger when improperly installed, operated, or maintained. To prevent accidents be aware of potential dangers and act safely. Read and follow all safety precautions and instructions. **SAVE THESE INSTRUCTIONS.**

This manual has several types of safety precautions and instructions: Danger, Warning, Caution, and Notice.

## **DANGER**

**DANGER** indicates a hazardous situation which, if not avoided, will result in death or serious injury.

## **WARNING**

**WARNING** indicates a hazardous situation which, if not avoided, could result in death or serious injury.

## **CAUTION**





**CAUTION** indicates a hazardous situation which, if not avoided, could result in minor or moderate injury.

## **NOTICE**

**NOTICE** is used to address practices not related to physical injury.



Safety decals affixed to the equipment in prominent places alert the operator or service technician to potential hazards and explain how to act safely. The decals are shown throughout this publication to improve operator recognition. Replace missing or damaged decals.



## Accidental Starting

|  |
|--|
|  <b>WARNING</b>   |
|    |
| <b>Accidental starting.</b><br><b>Can cause severe injury or death.</b>  |
| Disconnect the battery cables before working on the generator set. Remove the negative (-) lead first when disconnecting the battery. Reconnect the negative (-) lead last when reconnecting the battery.  |

**Disabling the generator set. Accidental starting can cause severe injury or death.** Before working on the generator set or equipment connected to the set, disable the generator set as follows: (1) Move the generator set master switch to the OFF position. (2) Disconnect the power to the battery charger. (3) Remove the battery cables, negative (-) lead first. Reconnect the negative (-) lead last when reconnecting the battery. Follow these precautions to prevent starting of the generator set by an automatic transfer switch, remote start/stop switch, or engine start command from a remote computer.

## Battery

|  |
|--|
|  <b>WARNING</b> |
|                 |
| <b>Sulfuric acid in batteries.</b><br><b>Can cause severe injury or death.</b>                     |
| Wear protective goggles and clothing. Battery acid may cause blindness and burn skin.              |

|   |
|---|
|  <b>WARNING</b>                          |
|    |
| <b>Explosion.</b><br><b>Can cause severe injury or death.</b><br><b>Relays in the battery charger cause arcs or sparks.</b> |
| Locate the battery in a well-ventilated area. Isolate the battery charger from explosive fumes.                             |


**Battery electrolyte is a diluted sulfuric acid. Battery acid can cause severe injury or death.** Battery acid can cause blindness and burn skin. Always wear splashproof safety goggles, rubber gloves, and boots when servicing the battery. Do not open a sealed battery or mutilate the battery case. If battery acid splashes in the eyes or on the skin, immediately flush the affected area for 15 minutes with large quantities of clean water. Seek immediate medical aid in the case of eye contact. Never add acid to a battery after placing the battery in service, as this may result in hazardous spattering of battery acid.

**Battery acid cleanup. Battery acid can cause severe injury or death.** Battery acid is electrically conductive and corrosive. Add 500 g (1 lb.) of bicarbonate of soda (baking soda) to a container with 4 L (1 gal.) of water and mix the neutralizing solution. Pour the neutralizing solution on the spilled battery acid and continue to add the neutralizing solution to the spilled battery acid until all evidence of a chemical reaction (foaming) has ceased. Flush the resulting liquid with water and dry the area.

**Battery gases. Explosion can cause severe injury or death.** Battery gases can cause an explosion. Do not smoke or permit flames or sparks to occur near a battery at any time, particularly when it is charging. Do not dispose of a battery in a fire. To prevent burns and sparks that could cause an explosion, avoid touching the battery terminals with tools or other metal objects. Remove all jewelry before servicing the equipment. Discharge static electricity from your body before touching batteries by first touching a grounded metal surface away from the battery. To avoid sparks, do not disturb the battery charger connections while the battery is charging. Always turn the battery charger off before disconnecting the battery connections. Ventilate the compartments containing batteries to prevent accumulation of explosive gases.

**Battery short circuits. Explosion can cause severe injury or death.** Short circuits can cause bodily injury and/or equipment damage. Disconnect the battery before generator set installation or maintenance. Remove all jewelry before servicing the equipment. Use tools with insulated handles. Remove the negative (-) lead first when disconnecting the battery. Reconnect the negative (-) lead last when reconnecting the battery. Never connect the negative (-) battery cable to the positive (+) connection terminal of the starter solenoid. Do not test the battery condition by shorting the terminals together.

## Engine Backfire/Flash Fire


|   |
|---|
| <b>⚠ WARNING</b>  |
|    |
| <p><b>Risk of fire.</b><br/> <b>Can cause severe injury or death.</b></p> <p>Do not smoke or permit flames or sparks near fuels or the fuel system.</p> |

**Servicing the air cleaner. A sudden backfire can cause severe injury or death.** Do not operate the generator set with the air cleaner removed.

**Servicing the fuel system. A flash fire can cause severe injury or death.** Do not smoke or permit flames or sparks near the carburetor, fuel line, fuel filter, fuel pump, or other potential sources of spilled fuels or fuel vapors. Catch fuels in an approved container when removing the fuel line or carburetor.

**Combustible materials. A fire can cause severe injury or death.** Generator set engine fuels and fuel vapors are flammable and explosive. Handle these materials carefully to minimize the risk of fire or explosion. Equip the compartment or nearby area with a fully charged fire extinguisher. Select a fire extinguisher rated ABC or BC for electrical fires or as recommended by the local fire code or an authorized agency. Train all personnel on fire extinguisher operation and fire prevention procedures.

## Exhaust System

|  |
|--|
| <b>⚠ WARNING</b>   |
|    |
| <p><b>Carbon monoxide.</b><br/> <b>Can cause severe nausea, fainting, or death.</b></p> <p>The exhaust system must be leakproof and routinely inspected.</p> |

**Generator set operation. Carbon monoxide can cause severe nausea, fainting, or death.** Carbon monoxide is an odorless, colorless, tasteless, nonirritating gas that can cause death if inhaled for even a short time. Avoid breathing exhaust fumes when working on or near the generator set. Never operate the generator set inside a building. Never operate the generator set where exhaust gas could seep inside or be drawn into a potentially occupied building through windows, air intake vents, or other openings.

**Carbon monoxide symptoms. Carbon monoxide can cause severe nausea, fainting, or death.** Carbon monoxide is a poisonous gas present in exhaust gases. Carbon monoxide is an odorless, colorless, tasteless, nonirritating gas that can cause death if inhaled for even a short time. Carbon monoxide poisoning symptoms include but are not limited to the following:

- Light-headedness, dizziness
- Physical fatigue, weakness in joints and muscles
- Sleepiness, mental fatigue, inability to concentrate or speak clearly, blurred vision
- Stomachache, vomiting, nausea



If experiencing any of these symptoms and carbon monoxide poisoning is possible, seek fresh air immediately and remain active. Do not sit, lie down, or fall asleep. Alert others to the possibility of carbon monoxide poisoning. Seek medical attention if the condition of affected persons does not improve within minutes of breathing fresh air.

## Fuel System

|   |
|---|
| <b>⚠ WARNING</b>  |
|    |
| <p><b>Explosive fuel vapors.</b><br/> <b>Can cause severe injury or death.</b></p> <p>Use extreme care when handling, storing, and using fuels.</p> |




**Gas fuel leaks. Explosive fuel vapors can cause severe injury or death.** Fuel leakage can cause an explosion. Check the LPG vapor or natural gas fuel system for leakage by using a soap and water solution with the fuel system test pressurized to 6-8 ounces per square inch (10-14 inches water column). Do not use a soap solution containing either ammonia or chlorine because both prevent bubble formation. A successful test depends on the ability of the solution to bubble.



## Hazardous Noise


|   |
|---|
|  <b>CAUTION</b>  |
|    |
| <p><b>Hazardous noise.</b><br/><b>Can cause hearing loss.</b></p> <p>Never operate the generator set without a muffler or with a faulty exhaust system.</p> |

**Engine noise. Hazardous noise can cause hearing loss.** Generator sets not equipped with sound enclosures can produce noise levels greater than 105 dBA. Prolonged exposure to noise levels greater than 85 dBA can cause permanent hearing loss. Wear hearing protection when near an operating generator set.

## Hazardous Voltage/ Moving Parts

|  |
|--|
|  <b>DANGER</b>   |
|                      |
| <p><b>Hazardous voltage. Moving parts.</b><br/><b>Will cause severe injury or death.</b></p> <p>Operate the generator set only when all guards and electrical enclosures are in place.</p> |

|   |
|---|
|  <b>WARNING</b>  |
|    |
| <p><b>Hazardous voltage. Backfeed to the utility system.</b><br/><b>Can cause property damage, severe injury, or death.</b></p> <p>If the generator set is used for standby power, install an automatic transfer switch to prevent inadvertent interconnection of standby and normal sources of supply.</p> |

|  |
|--|
|  <b>CAUTION</b>   |
| <p><b>Welding the generator set.</b><br/><b>Can cause severe electrical equipment damage.</b></p> <p>Welding on generator set will cause serious damage to engine electronic controls components. Disconnect all engine electronic control connections before welding.</p> |

**Grounding electrical equipment. Hazardous voltage will cause severe injury or death.** Electrocution is possible whenever electricity is present. Ensure you comply with all applicable codes and standards. Electrically ground the generator set, transfer switch, and related equipment and electrical circuits. Turn off the main circuit breakers of all power sources before servicing the equipment. Never contact electrical leads or appliances when standing in water or on wet ground because these conditions increase the risk of electrocution.

**Welding on the generator set. Can cause severe electrical equipment damage.** Before welding on the generator set perform the following steps: (1) Remove the battery cables, negative (-) lead first. (2) Disconnect all engine electronic control module (ECM) connectors. (3) Disconnect all generator set controller and voltage regulator circuit board connectors. (4) Disconnect the engine battery-charging alternator connections. (5) Attach the weld ground connection close to the weld location.



**Connecting the battery and the battery charger. Hazardous voltage will cause severe injury or death.** Reconnect the battery correctly, positive to positive and negative to negative, to avoid electrical shock and damage to the battery charger and battery(ies). Have a qualified electrician install the battery(ies).

**Short circuits. Hazardous voltage/current will cause severe injury or death.** Short circuits can cause bodily injury and/or equipment damage. Do not contact electrical connections with tools or jewelry while making adjustments or repairs. Remove all jewelry before servicing the equipment.


**Electrical backfeed to the utility. Hazardous backfeed voltage can cause severe injury or death.** Install a transfer switch in standby power installations to prevent the connection of standby and other sources of power. Electrical backfeed into a utility electrical system can cause severe injury or death to utility personnel working on power lines.

Wear protective goggles and clothing when using power tools, hand tools, or compressed air.

## Heavy Equipment

|   |
|---|
|  <b>WARNING</b>  |
|    |
| <p><b>Unbalanced weight.</b><br/><b>Improper lifting can cause severe injury or death and equipment damage.</b></p> <p>Do not use lifting eyes.<br/>Lift the generator set using lifting bars inserted through the lifting holes on the skid.</p> |

## Hot Parts

|   |
|---|
| <b>⚠ WARNING</b>  |
|  |
| <b>Hot engine and exhaust system.<br/>Can cause severe injury or death.</b>       |
| Do not work on the generator set until it cools.                                  |

**Servicing the exhaust system. Hot parts can cause severe injury or death.** Do not touch hot engine parts. The engine and exhaust system components become extremely hot during operation.

**Servicing the engine heater. Hot parts can cause minor personal injury or property damage.** Install the heater before connecting it to power. Operating the heater before installation can cause burns and component damage. Disconnect power to the heater and allow it to cool before servicing the heater or nearby parts.

## Notice

### NOTICE

**Canadian installations only.** For standby service connect the output of the generator set to a suitably rated transfer switch in accordance with Canadian Electrical Code, Part 1.



This manual provides operation and maintenance instructions for residential/commercial generator sets equipped with ADC-RES controls. The generator set models covered by this manual are listed on the front cover.

This generator set is approved for use in stationary applications in locations served by a reliable utility power source. Have the generator set installed by an authorized distributor/dealer or service technician. Refer to TP-6514, Installation Manual, for installation instructions.

Information in this publication represents data available at the time of print. Kohler Co. reserves the right to change this publication and the products represented without notice and without any obligation or liability whatsoever.

Read this manual and carefully follow all procedures and safety precautions to ensure proper equipment operation and to avoid bodily injury. Read and follow the Safety Precautions and Instructions section at the beginning of this manual. Keep this manual with the equipment for future reference.

The equipment service requirements are very important to safe and efficient operation. Inspect the parts often and perform required service at the prescribed intervals. Obtain service from an authorized service distributor/dealer to keep equipment in top condition.

## List of Related Literature

Figure 1 identifies literature available for the generator sets covered in this manual and related accessories. Only trained and qualified personnel should install or service the generator set.

| <b>Generator Set Literature</b>  | <b>Part Number</b> |
|--|--------------------|
| Specification Sheet, 8.5RES  | G4- 97             |
| Specification Sheet, 12RES   | G4- 248            |
| Specification Sheet, 17RES   | G4- 120            |
| Specification Sheet, 18RES   | G4- 133            |
| Installation Manual, Generator Set, 8.5/18RES, 12/18TRES                 | TP-6792            |
| Installation Manual, Generator Set , 12RES                               | TP- 6967           |
| Service Manual, Generator Set,8.5/12RES                                  | TP-6196            |
| Service Manual, Generator Set, 17/18RES, 18TRES                          | TP- 6519           |
| <b>Accessory Literature</b>  |                    |
| Operation Manual, SiteTech™ Software                                     | TP- 6701           |
| Installation Instructions, Load Shed Kit                                 | TT- 1609           |
| Installation Instructions, Programmable Interface Module (PIM)           | TT- 1584           |
| Installation Instructions, PowerSync® Automatic Paralleling Module (APM) | TT-1596            |
| Installation Instructions, Battery Heater Kit                            | TT- 1634           |
| Installation Instructions, Carburettor Heater Kit                        | TT- 1297           |

**Figure 1** Related Literature

## Nameplate

The following illustration shows a typical generator set nameplate. Copy the model, serial, and specification numbers from the nameplate into the spaces provided in the product information section on the inside front cover of this manual. See Section 1.6 for the nameplate location.

|                                    |      |       |                                    |       |      |  |
|------------------------------------|------|-------|------------------------------------|-------|------|--|
| <b>KOHLER®</b>                     |      |       |                                    |       |      |  |
| MODEL:                             |      |       | SERIAL:                            |       |      |  |
| SPEC:                              |      |       | BUILD DATE MM/YY                   |       |      |  |
| HZ:                                |      | RPM:  |                                    | FUEL: |      |  |
| VOLTAGE                            | AMPS | PHASE | KVA                                | KVA   | P.F. |  |
| GEN. MODEL:                        |      |       | BATT.                              |       | V    |  |
| INSUL. NEMA CLASS _____, 40°C AMB. |      |       | KW VARIES WITH BTU CONTENT OF FUEL |       |      |  |
|                                    |      |       |                                    |       |      |  |
|                                    |      |       |                                    |       |      |  |
| MATL:                              |      |       |                                    |       |      |  |

## Emission Information

The Kohler® Model CH640 engine used on the model 8.5RES generator set, CH740 engine used on the 12RES generator set, and CH980 engine used on the 17/18RES generator set are certified to operate using natural gas or propane fuel.

The Emission Compliance Period referred to on the Emission Control or Air Index label indicates the number of operating hours for which the engine has been shown to meet CARB or EPA emission requirements. The following table provides the engine compliance period (in hours) associated with the category descriptor, which may be found on the certification label.

| Emission Compliance Period |                         |                           |                          |
|----------------------------|-------------------------|---------------------------|--------------------------|
| EPA                        | Category C<br>250 hours | Category B<br>500 hours   | Category A<br>1000 hours |
| CARB                       | Moderate<br>125 hours   | Intermediate<br>250 hours | Extended<br>500 hours    |

**Figure 2** Emission Compliance Period

Refer to the certification label for engine displacement.

The exhaust emission control system for the CH640, CH740, and CH980 engines is EM for U.S. EPA, California, and Europe.

The engine used in the Model 17/18RES generator set is certified for emergency standby use only.

For professional advice on generator set power requirements and conscientious service, please contact your nearest Kohler distributor or dealer.

- Visit the Kohler Co. website at KOHLERPower.com.
- Look at the labels and decals on your Kohler product or review the appropriate literature or documents included with the product.
- Call toll free in the US and Canada 1-800-544-2444.
- Outside the US and Canada, call the nearest regional office.

## **Headquarters Europe, Middle East, Africa (EMEA)**

Kohler EMEA Headquarters  
Netherlands B.V.  
Kristallaan 1  
4761 ZC Zevenbergen  
The Netherlands  
Phone: (31) 168 331630  
Fax: (31) 168 331631

## **Asia Pacific**

Power Systems Asia Pacific Regional Office  
Singapore, Republic of Singapore  
Phone: (65) 6264-6422  
Fax: (65) 6264-6455

## **China**

North China Regional Office, Beijing  
Phone: (86) 10 6518 7950  
(86) 10 6518 7951  
(86) 10 6518 7952  
Fax: (86) 10 6518 7955

East China Regional Office, Shanghai  
Phone: (86) 21 6288 0500  
Fax: (86) 21 6288 0550

## **India, Bangladesh, Sri Lanka**

India Regional Office  
Bangalore, India  
Phone: (91) 80 3366208  
(91) 80 3366231  
Fax: (91) 80 3315972

## **Japan, Korea**

North Asia Regional Office  
Tokyo, Japan  
Phone: (813) 3440-4515  
Fax: (813) 3440-2727

# Notes

## 1.1 Introduction

The generator set specification sheets provide specific generator and engine information. Refer to the spec sheet for data not supplied in this manual. Consult the generator set service manual, engine operation manual, and engine service manual for additional specifications. Obtain copies of the latest spec sheets, manuals, diagrams, and drawings from your local distributor/dealer.

## 1.2 Generator

The generator uses Kohler's unique PowerBoost™ voltage regulation system, which provides instant response to load changes.

PowerBoost™ ensures reliable motor starting and consistent voltage levels. PowerBoost™ utilizes a voltage excitation system that employs a winding independent of the main output windings to provide excitation voltage.

## 1.3 Engine

The generator set has a four-cycle, twin cylinder, air-cooled Kohler® engine. The engine operates on clean-burning natural gas or propane (LP) vapor. Engine features include:

- Efficient overhead valve design and full pressure lubrication for maximum power, torque, and reliability under all operating conditions.
- Dependable, maintenance-free electronic ignition.
- Precision-formulated cast iron construction of parts subjected to the most wear and tear.
- Field-convertible multi-fuel systems that allow fuel changeover from natural gas to LP vapor (and vice-versa) while maintaining CARB emission certification.
- Digital spark advance optimizes ignition timing for the selected fuel. (12 - 18 kW models)

## 1.4 Advanced Digital Control

The generator set is equipped with the Kohler® ADC-RES Advanced Digital Control. Controller features include the following:

- Compact controller
- Integrally mounted to the generator set
- LED display:
  - Engine runtime, hours
  - AC voltage
  - Frequency (Hz)
  - Battery voltage
  - Crank cycle status
  - Setup information
  - Application software version
- LED display communicates faults:
  - High battery voltage
  - High engine temperature
  - Low battery voltage
  - Low oil pressure
  - Overcrank safety
  - Overfrequency
  - Overspeed
  - Overvoltage
  - Underfrequency
  - Undervoltage
- Membrane keypad for configuration and adjustment
  - Password-protected user access to menus
  - Voltage, gain, and speed adjustment
  - System configuration (system voltage/frequency settings and generator set model)
- Remote two-wire start/stop capability
- Digital isochronous governor to maintain steady-state speed at all loads
- Digital voltage regulation:  $\pm 1.5\%$  RMS no-load to full-load
- Automatic start for programmed cranking cycle
- Master control switch mounted on the junction box: Run/Off-Reset/Auto
- Upgradeable application software

## 1.5 Accessories

The following optional accessories are offered for the generator sets.

### 1.5.1 Carburetor Heater

An optional carburetor heater is recommended for improved cold starting in locations where the ambient temperature drops below 0°C (32°F). The carburetor heater prevents condensation and carburetor icing. The heater requires a continuous source of AC power.

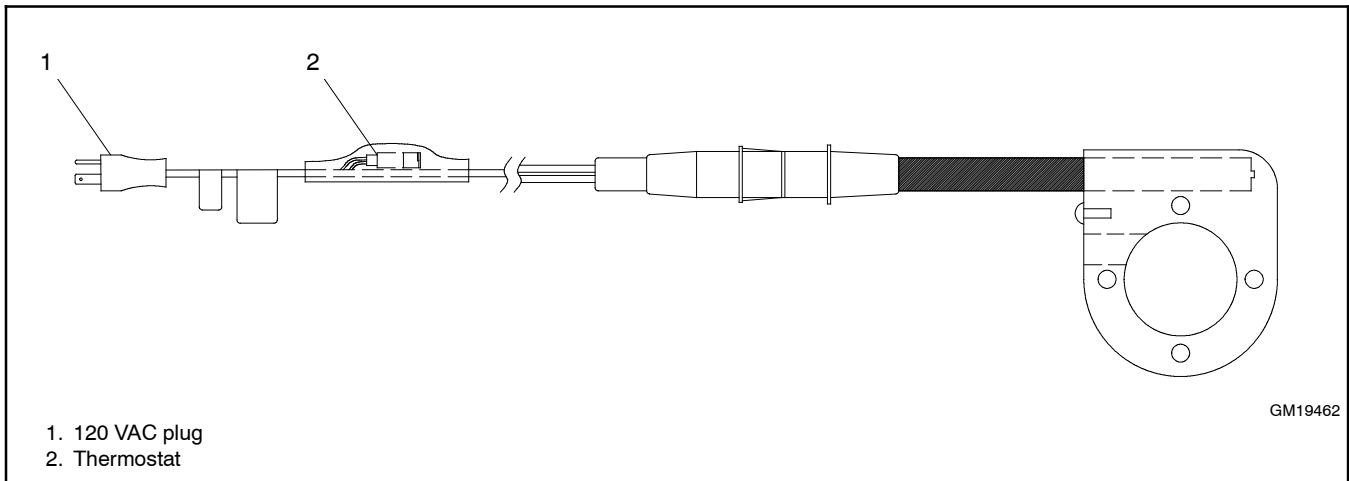
Install the heater between the engine air cleaner and the carburetor. Plug the carburetor heater into a 120 VAC

receptacle. Verify that AC power is connected to the generator set as described in the generator set Installation Manual. The circuit must be backed up by the generator set to provide power at all times.

See the generator set Installation manual for more information.

|                |                     |
|----------------|---------------------|
| Voltage        | 120 VAC             |
| Thermostat ON  | 4 ± 3°C (40 ± 5°F)  |
| Thermostat OFF | 16 ± 3°C (60 ± 5°F) |

**Figure 3** Heater Specifications



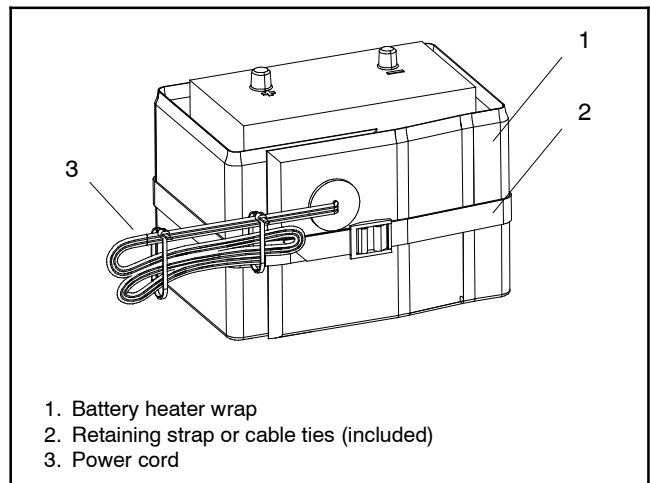
**Figure 4** Carburetor Heater

### 1.5.2 Battery Heater Kit

The battery heater kit contains a heating wrap to help warm the battery in cold climates. See Figure 5. The battery heater is equipped with a thermostat that turns the heater on at 16- 18°C (60- 65°F) and off at 27°C (80°F). Battery heaters are recommended for regions where the temperature regularly falls below 0°C (32°F).

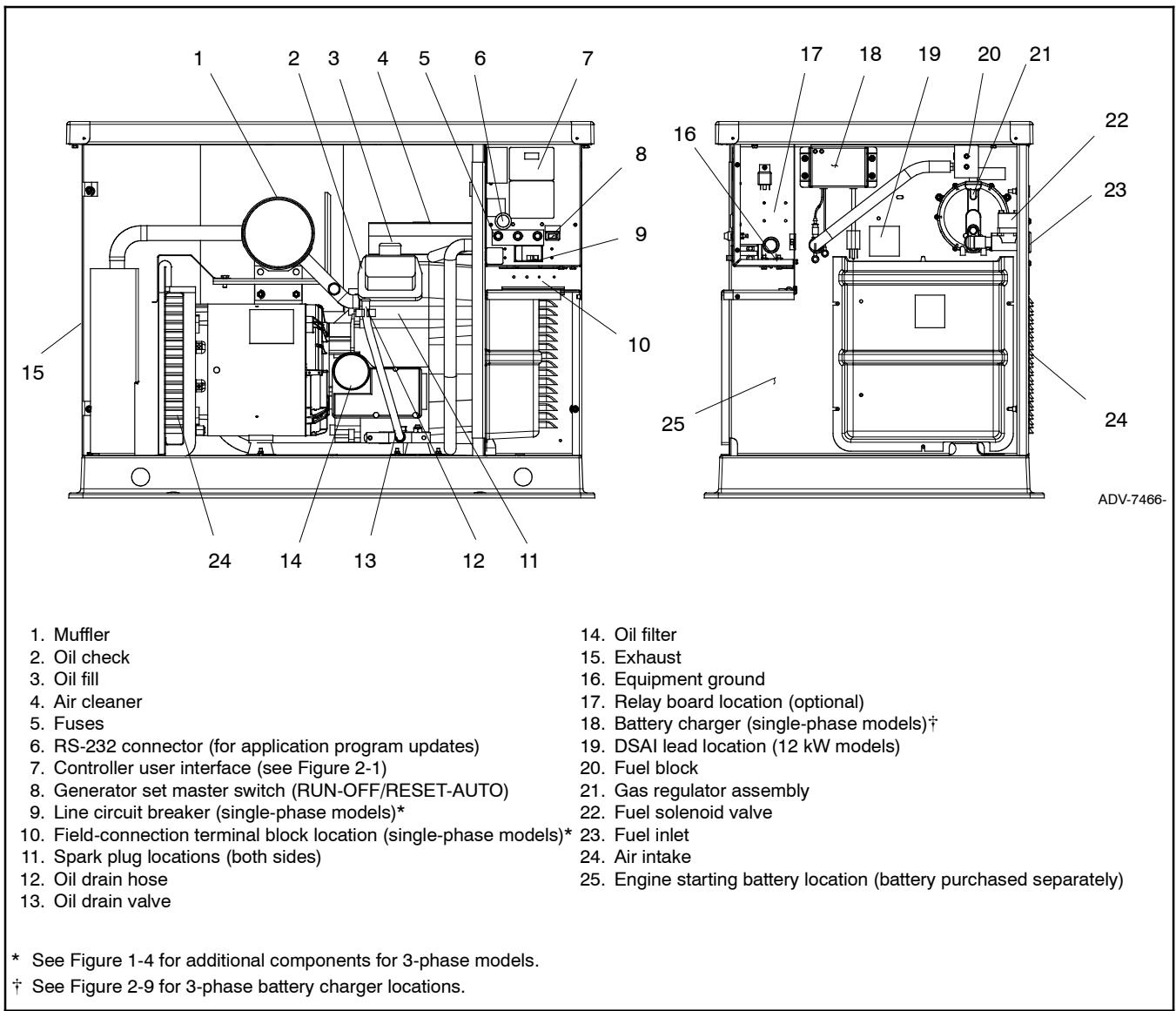
**Note:** Battery heaters are compatible with all Kohler-supplied lead-acid batteries.\* For other battery types, check the battery manufacturer's instructions for any restrictions regarding the use of battery heaters.

The battery heater requires a source of AC power. Verify that AC power is connected to the generator set as described in the generator set Installation Manual. The circuit must be backed up by the generator set to provide power at all times.

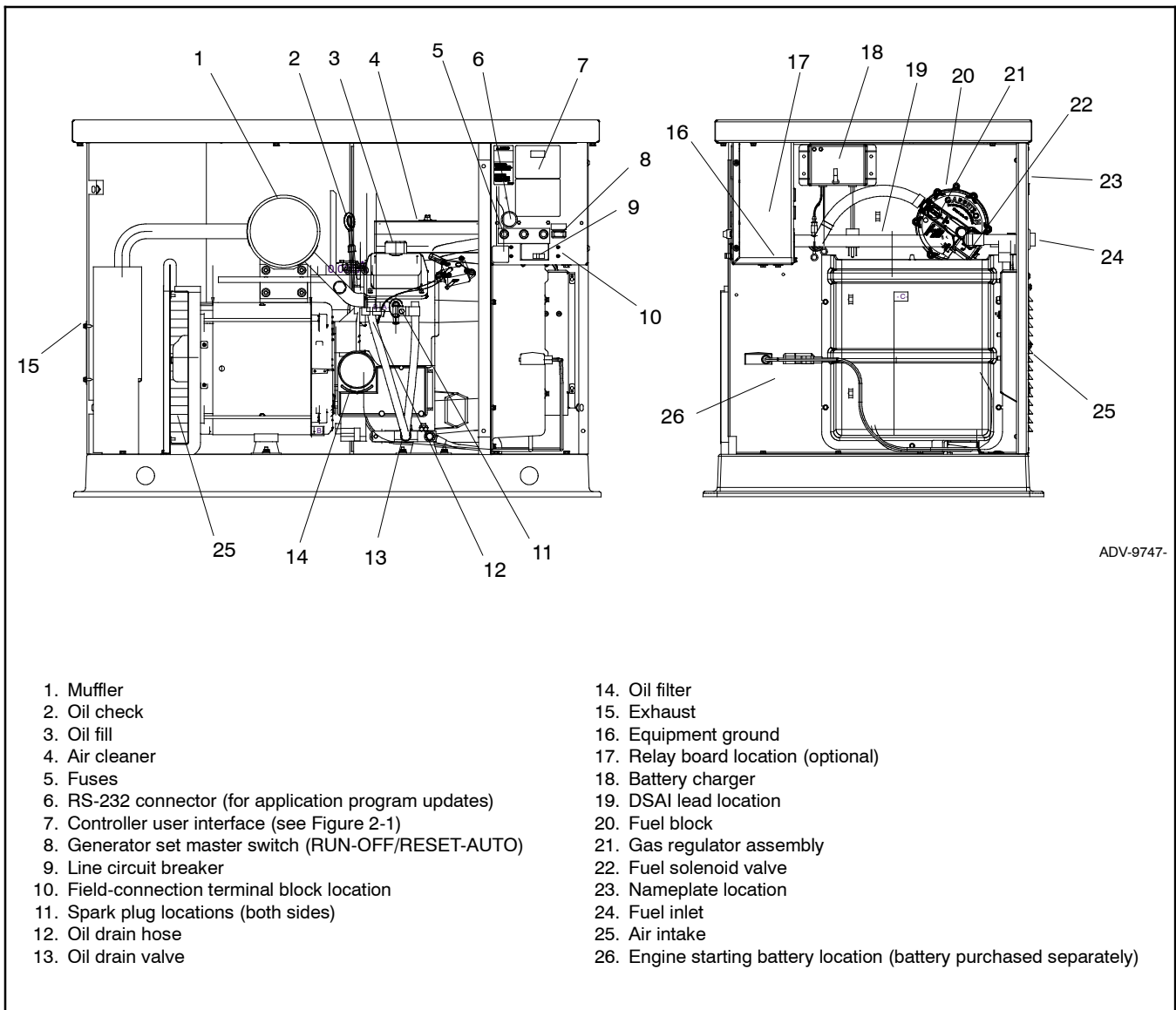


**Figure 5** Battery Heater (typical)

## 1.6 Service Views for Maintenance

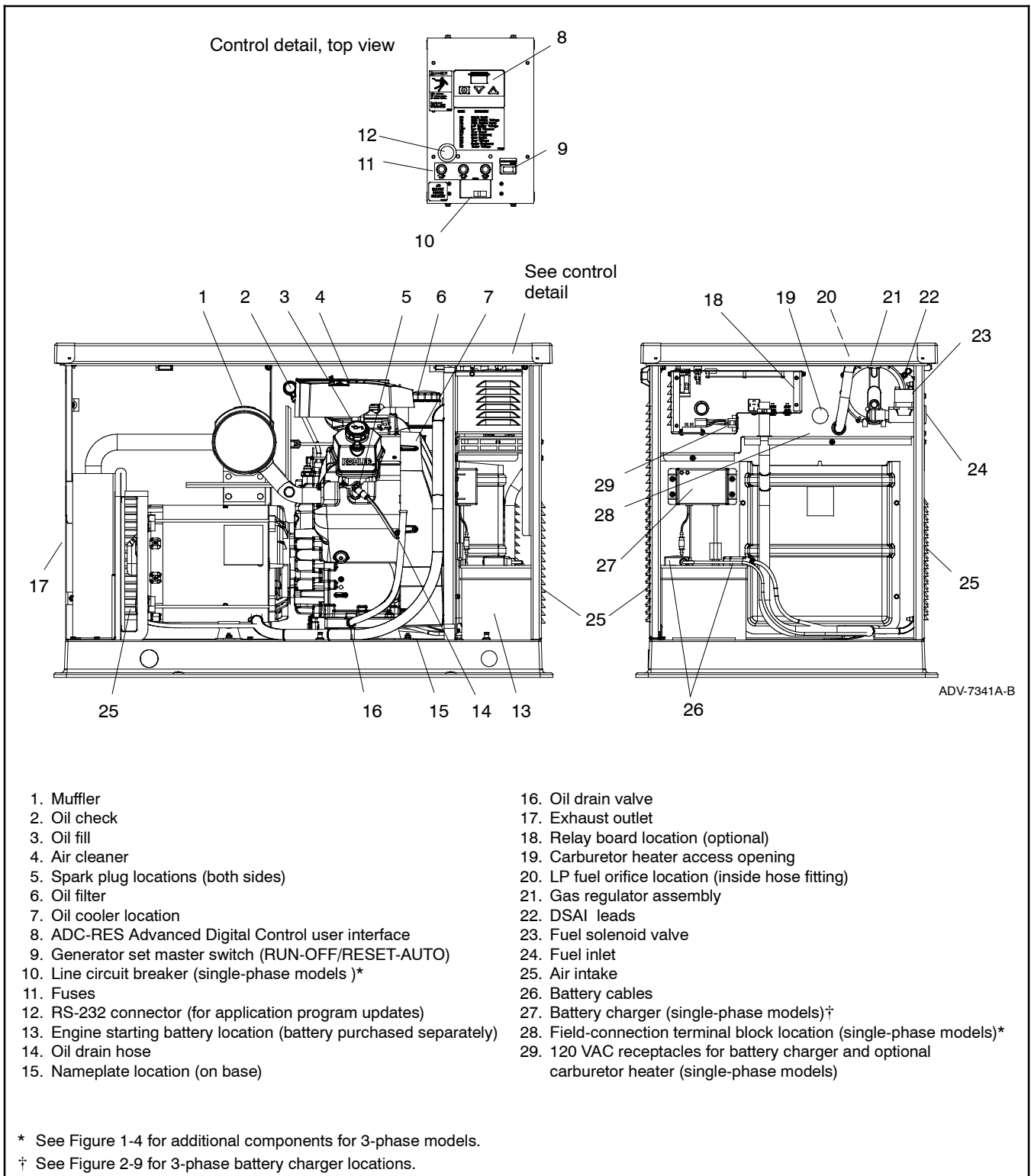


**Figure 1-1** Generator Set Components, 8.5kW

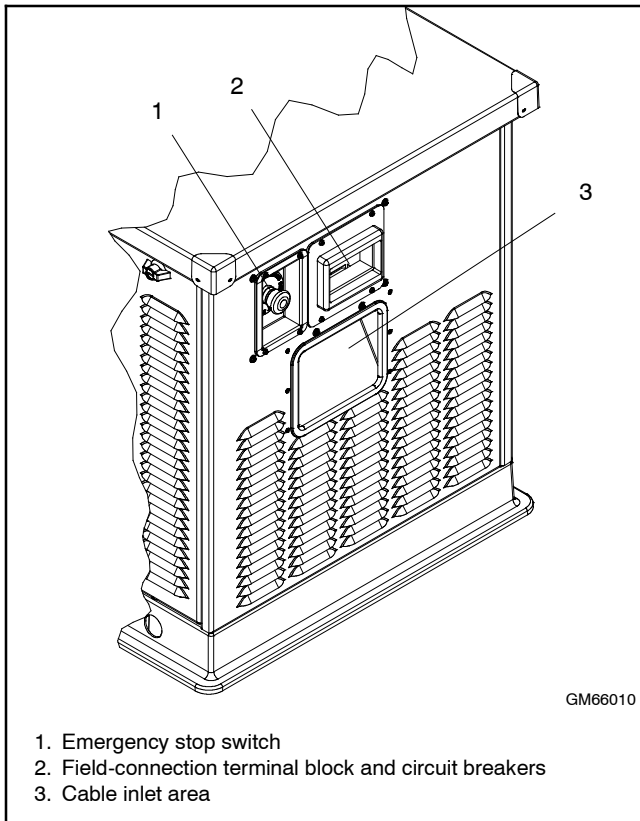


**Figure 1-2** Generator Set Components, 12kW



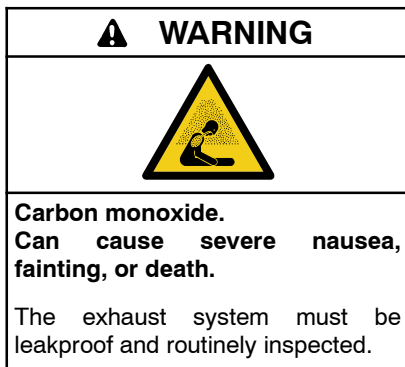
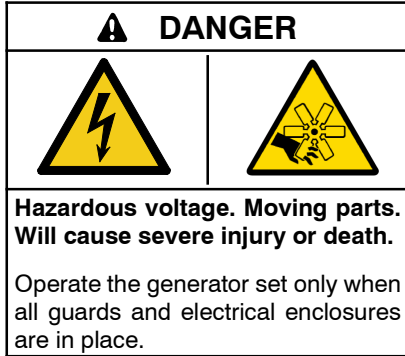


**Figure 1-3** Generator Set Components, 17/18 kW



**Figure 1-4** Additional Components, TRES (3-phase) Models

## 2.1 Operating Area



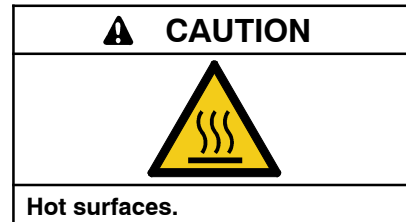
**Generator set operation. Carbon monoxide can cause severe nausea, fainting, or death.** Carbon monoxide is an odorless, colorless, tasteless, nonirritating gas that can cause death if inhaled for even a short time. Avoid breathing exhaust fumes when working on or near the generator set. Never operate the generator set inside a building. Never operate the generator set where exhaust gas could seep inside or be drawn into a potentially occupied building through windows, air intake vents, or other openings.

**Carbon monoxide symptoms. Carbon monoxide can cause severe nausea, fainting, or death.** Carbon monoxide is a poisonous gas present in exhaust gases. Carbon monoxide is an odorless, colorless, tasteless, nonirritating gas that can cause death if inhaled for even a short time. Carbon monoxide poisoning symptoms include but are not limited to the following:

- Light-headedness, dizziness
- Physical fatigue, weakness in joints and muscles
- Sleepiness, mental fatigue, inability to concentrate or speak clearly, blurred vision
- Stomachache, vomiting, nausea

If experiencing any of these symptoms and carbon monoxide poisoning is possible, seek fresh air immediately and remain active. Do not sit, lie down, or fall asleep. Alert others to the possibility of carbon monoxide poisoning. Seek medical attention if the condition of affected persons does not improve within minutes of breathing fresh air.

**Carbon monoxide detectors. Carbon monoxide can cause severe nausea, fainting, or death.** Install carbon monoxide detectors on each level of any building adjacent to the generator set. Locate the detectors to adequately warn the building's occupants of the presence of carbon monoxide. Keep the detectors operational at all times. Periodically test and replace the carbon monoxide detectors according to the manufacturer's instructions.



Remind family members, children, and visitors to use caution near the generator set. Generator sets connected to automatic transfer switches will start automatically during exercise periods and power outages. Some generator components become hot when the generator is running and remain hot for a time after the generator set shuts down.

## 2.2 Prestart Checklist

To ensure continued satisfactory operation, perform the following checks or inspections before or at each startup, as designated, and at the intervals specified in the service schedule. In addition, some checks require verification after the unit starts.

**Air Cleaner.** Check for a clean and installed air cleaner element to prevent unfiltered air from entering the engine.

**Air Inlets.** Check for clean and unobstructed air inlets.

**Battery.** Check for tight battery connections. Consult the battery manufacturer's instructions regarding battery care and maintenance.

**Exhaust System.** Check for exhaust leaks and blockages. Check the muffler condition and check for tight exhaust system connections.

Inspect the exhaust system components for cracks, leaks, and corrosion.

- Check for corroded or broken metal parts and replace them as needed.
- Check that the exhaust outlet is unobstructed.

**Oil Level.** Maintain the oil level at or near, not over, the full mark on the dipstick.

**Operating Area.** Check for obstructions that could block the flow of cooling air. Keep the air intake area clean. Do not leave rags, tools, or debris on or near the generator set.

### 2.3 Exercising Generator Set

Operate the generator set without load once each week for 20 minutes. If the generator set is not connected to an automatic transfer switch (ATS) with an exercise option, exercise the unit in the presence of an operator.

The operator should perform all of the prestart checks before starting the exercise procedure. Start the generator set according to the starting procedure in the controller section of this manual. While the generator set is operating, listen for a smooth-running engine and visually inspect the generator set for fluid or exhaust leaks. Check the air inlets and outlets and remove any items restricting the air flow.

### 2.4 ADC-RES Controls and Indicators

Figure 2-1 illustrates the ADC-RES user interface and other items on the generator set junction box. Figure 2-2 describes the ADC-RES controls and indicators.

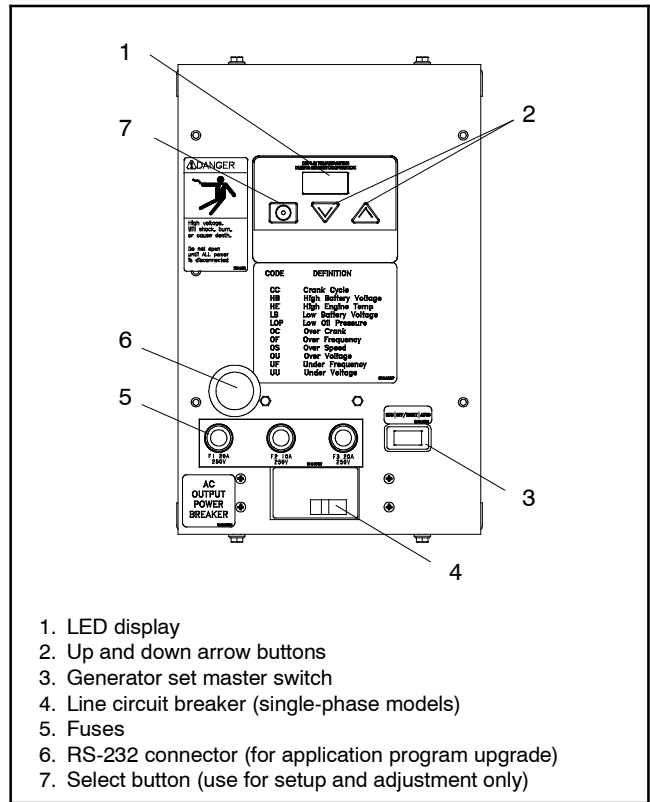


Figure 2-1 ADC-RES Controls

#### 2.4.1 LED Display

The LED display is activated by a start or RUN command as follows:

- Move the master switch to RUN.
- With the master switch in AUTO, send a remote start command (close the remote start contact across leads 3 and 4).

The LED display indicates generator set status as shown in Figure 2-2. When the generator set is running, engine runtime hours are shown unless the arrow buttons are used to step through the other displays as described in Section 2.4.2.

When the master switch is in AUTO, the display may turn off 48 hours after generator set shutdown. See Section 2.5, Controller Power.

| Control or Indicator        | Item                     | Description  |
|-----------------------------|--------------------------|--|
| LED display                 | Runtime hours            | Displays total generator set runtime hours while the generator set is running and when no other codes are displayed.   |
|                             | Metering display         | Displays AC voltage (output), frequency, and battery voltage. Press the up or down arrow when runtime hours are displayed to step through these displays.  |
|                             | Crank indication         | Displays CC_1, CC_2, or CC_3 to indicate the first, second, or third attempt to start the engine. The last digit flashes during the crank cycle rest periods.  |
|                             | Software version number  | The software version number (v#.##) is displayed when entering configuration mode. See the installation manual.  |
|                             | Fault codes              | Flashes a 2- or 3-letter fault code to indicate various fault conditions. See Section 2.7.   |
| Keypad                      | Select and arrow buttons | Use the arrow buttons to step through the data displays. See Figure 2-3.<br>The keypad is also used for controller setup and adjustment. The setup and adjustment functions are password-protected. Have setup and adjustments performed only by an authorized distributor/dealer. |
| Generator set master switch | Three-position switch    | Switch functions as the generator set operation and controller reset switch.   |

**Figure 2-2** ADC-RES Controls and Indicators

### 2.4.2 Controller Keypad

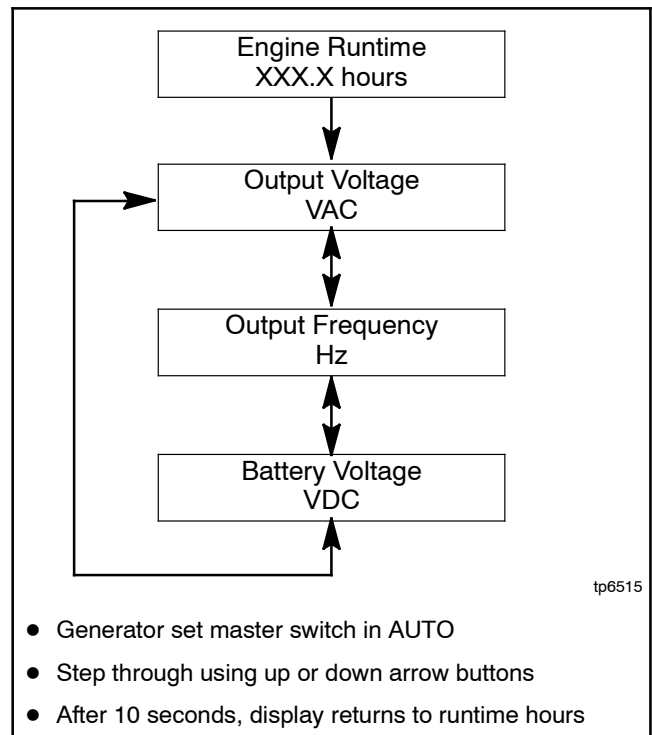
The three buttons on the controller keypad are Select, Up, and Down. See Figure 2-1.

When the generator set is running, the up and down arrow buttons can be used to step through system data displays as shown in Figure 2-3. After 10 seconds, the display returns to engine runtime hours.

The buttons on the controller keypad are also used for system configuration and adjustment. The system configuration is factory-set and should not require changes under normal operating conditions. Contact an authorized distributor/dealer or service technician if adjustments are required.

### 2.4.3 Generator Set Master Switch

The generator set master switch is located on the junction box below the ADC-RES user interface. The master switch positions are RUN, OFF/RESET, and AUTO. See Section 2.6 for operation instructions.



**Figure 2-3** Data Displays

## 2.5 Controller Power

The ADC-RES is powered by the generator set engine starting battery.

**Note:** The generator sets are equipped with factory-installed battery chargers to prevent battery discharge. The battery charger must be connected to utility power.

### 2.5.1 Standby Mode

When the generator set master switch is in the AUTO position and the engine is not running, the controller is in standby mode. Engine runtime hours are shown on the display. A remote start signal (contact closure) will start and run the generator set.

The controller can be set to go into sleep mode if there is no start signal for 48 hours.

### 2.5.2 Sleep Mode

Controllers with application code version 1.13 or higher are shipped with the sleep mode disabled and J1939 communication enabled. The controller will remain in standby mode whenever the master switch is in AUTO and the engine is not running.

Communication parameter Cn can be changed to disable communication and enable the sleep mode if remote communication is not required. See Installation Manual TP-6514 for instructions to change parameter Cn.

**Sleep Mode.** If the controller communication is disabled and the generator set master switch is in the AUTO position, the controller powers down automatically after 48 hours of inactivity. The controller display is dark and battery draw is minimized. A remote start signal from a transfer switch or a remote start/stop switch connected to controller leads 3 and 4 reactivates the controller. Moving the generator set master switch to the RUN position also activates the controller.

## 2.6 Generator Set Operation

### 2.6.1 Starting Generator Set

#### Local Starting

Move the generator set master switch to the RUN position to immediately start the generator set.

#### Auto (Automatic) Starting

Move the generator set master switch to the AUTO position to allow startup by an automatic transfer switch (ATS) or remote start/stop switch, if equipped. Close a contact across engine start leads 3 and 4 to signal the controller to start the generator set.

#### Crank Cycle

The controller attempts to start the generator set three times (three crank cycles, 15 seconds crank and 15 seconds off). See Figure 2-2 for display information during the crank cycle. If the generator set does not start in three attempts, the system shuts down on an overcrank fault. See Section 2.7.

### 2.6.2 Stopping Generator Set

#### Local Stopping

1. Run the generator set with no load for at least 2 minutes to ensure adequate engine cooldown.
2. Move the generator set master switch to the OFF/RESET position. The engine stops.

#### Automatic Stopping

With the generator set master switch in the AUTO position, open the contact across engine start leads 3 and 4 to signal the generator set to stop.

An automatic transfer switch (ATS) connected to controller leads 3 and 4 operates as follows:

1. The ATS disconnects the load from the generator set.
2. If the ATS is equipped with an engine cooldown time delay, the generator set continues to run for a preset engine cooldown time.

**Note:** There is no engine cooldown time delay on the ADC-RES controller.

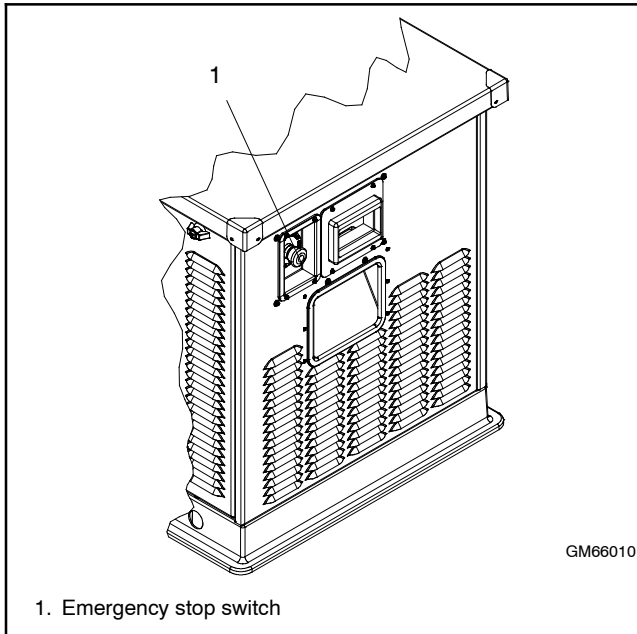
3. The ATS opens the connection between controller leads 3 and 4. The generator set shuts down. The controller enters standby mode and displays engine runtime hours.

### 2.6.3 Emergency Stopping (TRES Models Only)

Push the red emergency stop switch for immediate generator set shutdown in the case of an emergency. See Figure 2-4 for the emergency stop switch location.

The emergency stop switch shuts down the generator set immediately. The controller display shows AF (auxiliary fault) when the emergency stop button is activated.

Use the generator set master switch for normal shutdowns.



**Figure 2-4** Emergency Stop Switch, TRES Models

### Resetting Emergency Stop Switch (TRES Models only)

Use the following procedure to reset the generator set after shutdown by the emergency stop switch. See Section 2.7.3 to reset the generator set after a fault shutdown.

1. Place the generator set master switch in the OFF/RESET position.
2. Investigate and correct the cause of the emergency stop.
3. Rotate the emergency stop switch knob clockwise and release it. Check that the knob returns to the deactivated (out) position.
4. Move the generator set master switch to the RUN or AUTO position to restart the generator set. Verify that the controller display no longer shows a fault code. The generator set engine will not start until the reset procedure is complete.

## 2.7 Faults

### 2.7.1 Shutdowns

Under the fault shutdown conditions listed in Figure 2-5, the generator set shuts down automatically and the controller displays a fault code. The generator set cannot be restarted until the fault condition is corrected and the controller is reset. See Section 2.7.3 to reset the controller after a fault shutdown.

The shutdown switches on the generator set will automatically reset when the problem is corrected. For example, the high engine temperature switch resets automatically when the generator set cools. However, the fault does not clear until the controller is reset.

### 2.7.2 Warnings

The controller displays a fault code but the generator set does not shut down on a high battery voltage warning or a low battery voltage warning. The controller resets automatically after a battery voltage fault condition is corrected.

### 2.7.3 Resetting Controller after a Fault Shutdown

Always identify and correct the cause of a fault shutdown before resetting the controller. Check the fault code displayed on the ADC-RES and refer to Figure 2-5 to identify and correct the fault condition before proceeding.

Use the following procedure to reset the generator set controller after a fault shutdown.

1. Move the generator set master switch to OFF/RESET.
2. Disconnect the generator set from the load using the line circuit breaker or ATS. See the safety precautions at the beginning of this manual before proceeding.
3. Identify and correct the cause of the fault shutdown. See the safety precautions at the beginning of this manual before proceeding. Refer to Section 4, Troubleshooting.
4. Start the generator set by moving the generator set master switch to RUN. Test operate the generator set to verify that the cause of the shutdown has been corrected.
5. Move the generator set master switch to OFF/RESET.
6. Reconnect the generator set to the load using the line circuit breaker or ATS.
7. Move the generator set master switch to the AUTO position for startup by remote transfer switch or remote start/stop switch.

**Note:** The controller's LED display remains off until an engine start command is received.



| Code | Fault                            | Description   | Check  |
|------|----------------------------------|---|--|
| AF   | Auxiliary fault input shutdown   | Indicates a shutdown initiated by pushing the emergency stop switch. (TRES models only)<br>Not used on RES models.  | Check the position of the emergency stop button. (TRES models only)  |
| HE   | High engine temperature shutdown | Shutdown occurs if the engine coolant temperature exceeds the maximum temperature for more than 5 seconds. This function becomes active after the engine reaches the crank disconnect speed.  | Check for blocked air inlets and exhaust outlets.  |
| LOP  | Low oil pressure shutdown        | Shutdown occurs if a low oil pressure condition exists for more than 5 seconds. This function becomes active 30 seconds after the engine has reached crank disconnect speed (30 second inhibit).<br><b>Note:</b> The low oil pressure shutdown does not protect against low oil level. Check the oil level at the engine.             | Check for leaks in the lubrication system.<br>Check the oil level and add oil if the level is low.                           |
| OC   | Overcrank shutdown               | Shutdown occurs after 3 unsuccessful starting attempts. The crank cycle is set for three starting attempts of 15 seconds cranking and 15 seconds rest.  | Check the fuel supply, spark plug, and battery.<br>Check for loose connections.  |
|      | Locked rotor                     | The generator set also shuts down on OC if no engine rotation is sensed during cranking. Shuts down 3 seconds after the fault is detected.  | Contact an authorized distributor/dealer for service if problem continues.   |
| OF   | Overfrequency shutdown           | Shutdown occurs when the governed frequency exceeds 110% of the system's frequency setpoint for more than 5 seconds. This function becomes active 10 seconds after engine start (10 second inhibit).  | Contact an authorized distributor/dealer for service if problem continues.   |
| OS   | Overspeed shutdown               | Shutdown occurs if the engine speed exceeds 110% of the normal running speed for more than 0.3 seconds.   | Contact an authorized distributor/dealer for service if problem continues.   |
| OU   | Overvoltage shutdown             | Shutdown occurs if the voltage exceeds 120% of the system nominal voltage for more than 2 seconds.  | Contact an authorized distributor/dealer for service if problem continues.   |
| UF   | Underfrequency shutdown          | Shutdown occurs if the governed frequency falls below 54 Hz for more than 5 seconds.<br>Shutdown also occurs if the governed frequency falls below 56.5 Hz for more than 60 seconds.<br>This function becomes active 10 seconds after engine start. (10 second inhibit).  | Reduce the load and restart the generator set.<br>Contact an authorized distributor/dealer for service if problem continues. |
| UU   | Undervoltage shutdown            | Shutdown occurs if the voltage falls below 80% of the nominal system voltage for more than 10 seconds.  | Reduce the load and restart the generator set.<br>Contact an authorized distributor/dealer for service if problem continues. |
| HB   | High battery voltage warning     | Fault code is displayed if the engine starting battery voltage rises above 16 VDC for more than 30 seconds when the engine is running. Not operative during the engine crank cycle, this fault condition does not inhibit engine starting.<br>The fault condition clears when the battery voltage returns to an acceptable level.     | Check the battery rating and condition.<br>Check the battery charger operation.  |
| LB   | Low battery voltage warning      | Fault code is displayed if the engine starting battery voltage falls below 11 VDC for more than 30 seconds when the engine is not running. Not operative during the engine crank cycle, this fault condition does not inhibit engine starting.<br>The fault condition clears when the battery voltage returns to an acceptable level. | Check the battery rating and condition.<br>Check the battery charger operation.<br>Charge or replace the battery.            |

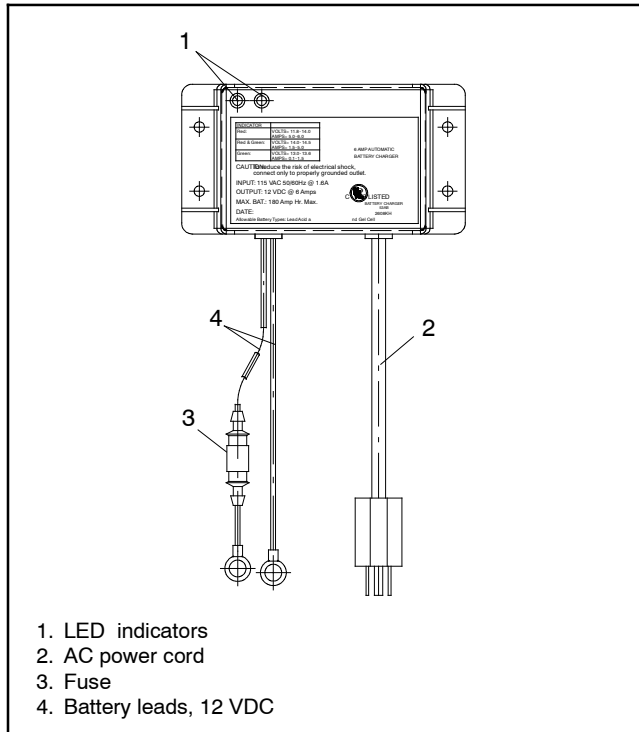
Figure 2-5 ADC-RES Fault Codes

## 2.8 Battery Charger

### 2.8.1 RES Battery Charger

RES model generator sets are equipped with a 6-amp float/equalize battery charger to maintain the engine starting battery. The charger's power cord must be connected to a 120 VAC power source. Figure 2-6 illustrates the battery charger.

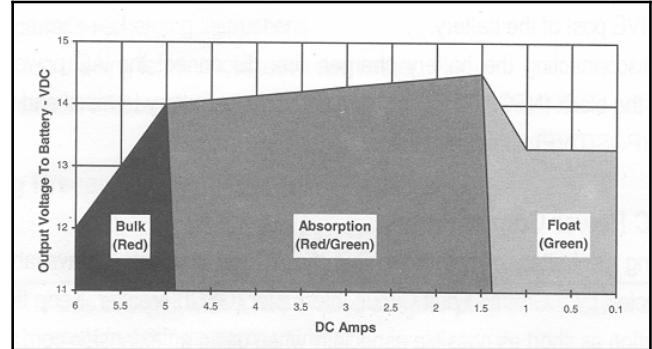
The battery charger uses an AGS 10 inline fuse. The fuse is located in the battery lead. See Figure 2-6.



**Figure 2-6** 6-Amp Float/Equalize Battery Charger

### Battery Charger Operation

Figure 2-7 illustrates the three-stage charging method. Red and green LEDs indicate charger operation. The chart in Figure 2-8 describes the LED indicator operation during each stage of the charging process. See Section 4.4 for battery charger troubleshooting information, if necessary.



**Figure 2-7** Charging Method

| Display             | Operating Condition   |
|---------------------|---|
| Red ON<br>Green OFF | When the red LED is on, it indicates the battery is discharged and the battery charger is recharging at the BULK rate (stage 1). This charging rate is 6 amps. While the red LED is on, the voltage measured (with the battery charger on) will be 11.8- 14 volts.<br><br>If the red LED stays on for more than 24 hours, refer to Section 4.4 in this manual.  |
| Red ON<br>Green ON  | When both the green and the red LEDs are on, the battery charger is charging at an ABSORPTION rate of between 1.5 and 5 amps (stage 2). This mode of charging gradually tops off your battery, and reduces harmful sulfating. While both LEDs are on, the voltage measured (with the battery charger on) should be approximately 14.0- 14.5 VDC.<br><br>If both LEDs stay on longer than 24 hours, refer to Section 4.4 in this manual.                         |
| Red OFF<br>Green ON | When the green LED is on, the battery charger is charging at a FLOAT or MAINTENANCE rate of less than 1.5 amps (stage 3). Your battery is now 90% charged and ready for use. This float charging current will gradually decrease to as low as 0.1 amps as the battery reaches 100% charge. It will now be kept at full charge without overcharging.<br><br>If the green LED stays on when your battery is known to be low, refer to Section 4.4 in this manual. |

**Figure 2-8** Battery Charger LED Indicator Functions

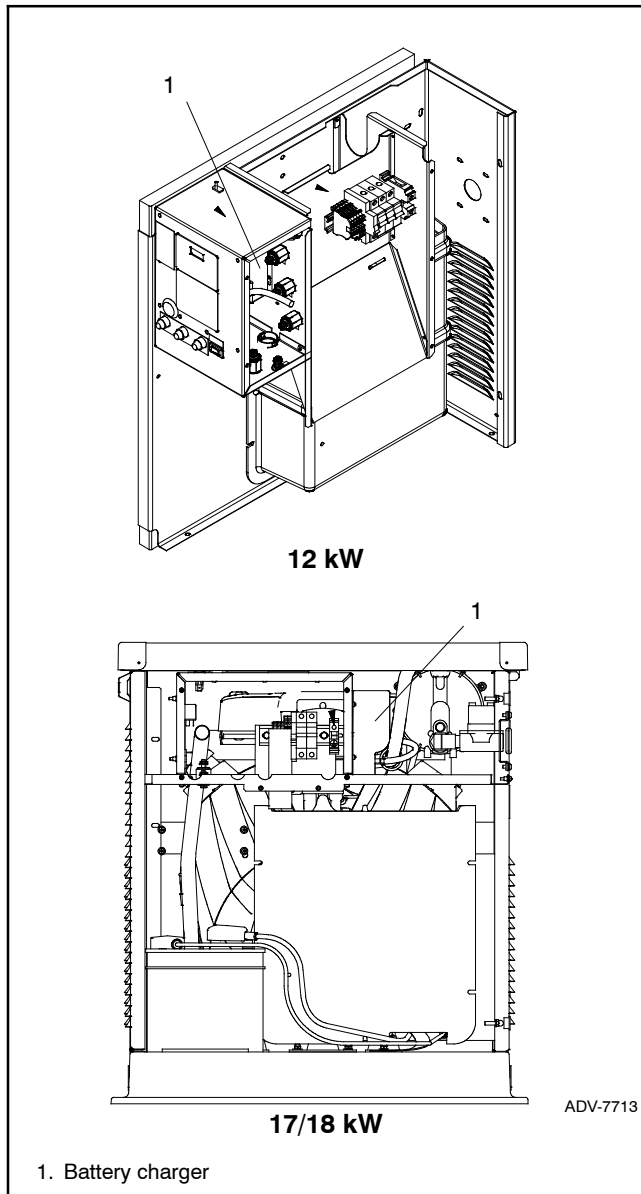
## 2.8.2 TRES Battery Charger

Three-phase model TRES generator sets are equipped with a 2.5-amp battery charger to maintain the engine starting battery. Utility power must be supplied to the generator set for the battery charger.

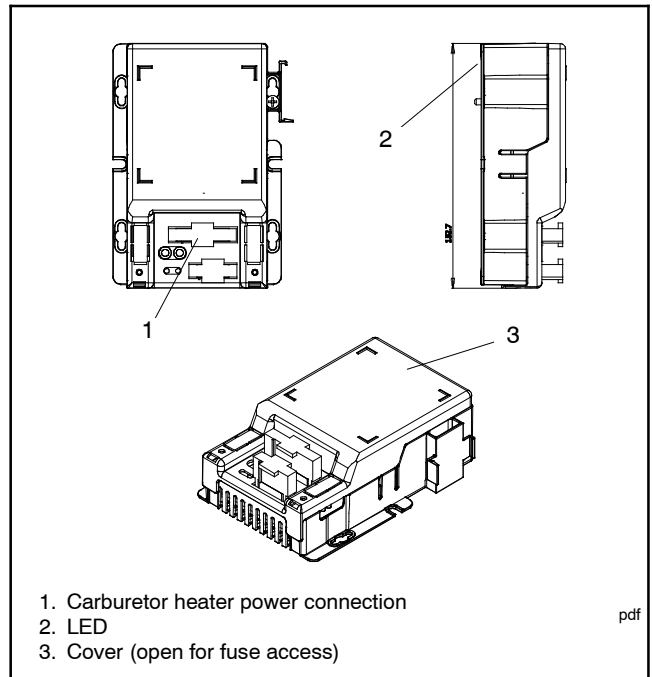
The battery charger is located in or near the controller junction box. See Figure 2-9 for the battery charger location.

A green LED on the side of the battery charger indicates battery charger operation. See Figure 2-10.

Two internal fuses protect the battery charger. See Section 4.4 for battery charger troubleshooting information, if necessary.



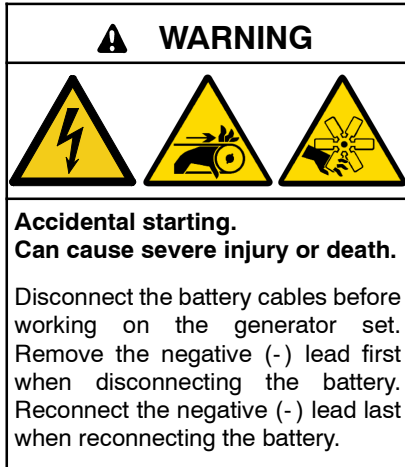
**Figure 2-9** Battery Charger Location, TRES (3-phase) Models



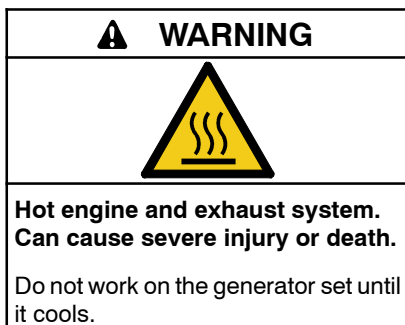
**Figure 2-10** Battery Charger for 3-Phase Models

# Notes

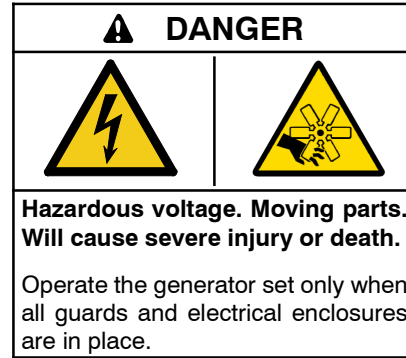
## Section 3 Scheduled Maintenance



**Disabling the generator set. Accidental starting can cause severe injury or death.** Before working on the generator set or equipment connected to the set, disable the generator set as follows: (1) Move the generator set master switch to the OFF position. (2) Disconnect the power to the battery charger. (3) Remove the battery cables, negative (-) lead first. Reconnect the negative (-) lead last when reconnecting the battery. Follow these precautions to prevent starting of the generator set by an automatic transfer switch, remote start/stop switch, or engine start command from a remote computer.



**Servicing the exhaust system. Hot parts can cause severe injury or death.** Do not touch hot engine parts. The engine and exhaust system components become extremely hot during operation.



**Servicing the generator set when it is operating. Exposed moving parts will cause severe injury or death.** Keep hands, feet, hair, clothing, and test leads away from the belts and pulleys when the generator set is running. Replace guards, screens, and covers before operating the generator set.

### 3.1 Scheduled Maintenance

Refer to the following service schedules and the runtime hours displayed on the ADC-RES display to schedule routine maintenance. Intervals are shown in hours of operation and/or time intervals (i.e. weekly, monthly, quarterly, etc.) Have an authorized distributor/dealer service the generator set at the designated intervals in the service schedule for the life of the generator set. Service units subject to extreme weather, long operating hours, or dusty or dirty conditions more frequently.

Contact an authorized distributor/dealer for parts.

### 3.1.1 Service Schedule, 8.5/12 kW Models

| System Component or Procedure   | See Section | Procedure                            |       |        |       |      | Frequency             |
|---|-------------|--------------------------------------|-------|--------|-------|------|-----------------------|
|   |             | Visually Inspect                     | Check | Change | Clean | Test |                       |
| <b>Fuel</b>   |             |                                      |       |        |       |      |                       |
| Flexible lines and connections  |             | X                                    |       | R      |       |      | Quarterly             |
| Main tank supply level  |             |                                      | X     |        |       |      | Weekly                |
| Fuel piping   |             | X                                    |       |        |       |      | Yearly                |
| <b>Lubrication</b>  |             |                                      |       |        |       |      |                       |
| Oil level   | 3.2         | X                                    | X     |        |       |      | 8 hours or before use |
| Crankcase breather hose   |             | X                                    |       |        |       |      | Yearly or 500 hours   |
| Change oil  |             |                                      |       | X      |       |      | Yearly or 100 hours   |
| Replace filter  |             |                                      |       | X      |       |      | Yearly or 200 hours   |
| <b>Cooling</b>  |             |                                      |       |        |       |      |                       |
| Air ducts, louvers  | 3.5         |                                      | X     |        | X     |      | Yearly                |
| <b>Exhaust Line</b>   |             |                                      |       |        |       |      |                       |
| Leakage   | 3.6         | X                                    | X     |        |       |      | Weekly                |
| Insulation, fire hazards  |             | X                                    |       |        |       |      | Yearly                |
| Obstructions or combustible materials near exhaust outlet   |             | X                                    |       |        |       |      | Weekly                |
| <b>DC Electrical System</b>   |             |                                      |       |        |       |      |                       |
| Battery charger operation, charge rate (if equipped)  | 3.7         | X                                    |       |        |       |      | Monthly               |
| Remove corrosion, clean and dry battery and rack  |             | X                                    |       |        | X     |      | Yearly                |
| Clean and tighten battery terminals and inspect boots   |             | X                                    | X     |        |       |      | Yearly                |
| Battery electrolyte level and specific gravity *  |             |                                      | X     |        |       |      | Yearly                |
| <b>AC Electrical System</b>   |             |                                      |       |        |       |      |                       |
| Tighten control and power wiring connections  |             |                                      | X     |        |       |      | Yearly                |
| Remote control system, if equipped  |             |                                      |       |        |       | X    | Monthly               |
| Visible wear or damage  |             | X                                    |       |        |       |      | Quarterly             |
| Wire abrasions where subject to motion  |             | X                                    | X     |        |       |      | Six Months            |
| Wire-cable insulation condition   |             | X                                    |       |        |       |      | 3 Years or 500 hours  |
| <b>Engine and Mounting</b>  |             |                                      |       |        |       |      |                       |
| Visible wear or damage  |             | X                                    |       |        |       |      | Weekly                |
| Air cleaner and precleaner service †  | 3.4         |                                      |       | R      |       |      | Yearly or 100 hours   |
| Spark plugs   | 3.3         |                                      |       | X      |       |      | Yearly or 300 hours   |
| Replace stepper motor coupling and bushing  |             |                                      |       | D      |       |      | 500 hours             |
| <b>Generator</b>  |             |                                      |       |        |       |      |                       |
| Visible wear or damage  |             | X                                    |       |        |       |      | Quarterly             |
| Exercise generator set  |             |                                      |       |        |       | X    | Weekly                |
| Brushes and collector ring  |             |                                      | D     |        | D     |      | Yearly                |
| Measure and record resistance readings of windings with insulation tester (Megger®, with SCR assembly or rectifier and load leads disconnected) * |             |                                      |       |        |       | D    | 3 Years               |
| <b>General Condition of Equipment</b>   |             |                                      |       |        |       |      |                       |
| Evidence of vibration, leakage, excessive noise, temperature, or deterioration  |             | X                                    | X     |        | X     |      | Weekly                |
| Interior of sound enclosure   |             | X                                    |       |        | X     |      | Quarterly             |
| * *Not necessary for maintenance-free batteries.  |             | X Action                             |       |        |       |      |                       |
| † Service more frequently under extremely dusty/dirty conditions.   |             | D Authorized distributor/dealer only |       |        |       |      |                       |
| Megger® is a registered trademark of Biddle Instruments.  |             | R Replace as necessary               |       |        |       |      |                       |

### 3.1.2 Service Schedule, 17/18 kW Models

| System Component or Procedure   | See Section | Procedure        |       |                                      |       |      | Frequency                  |
|---|-------------|------------------|-------|--------------------------------------|-------|------|----------------------------|
|   |             | Visually Inspect | Check | Change                               | Clean | Test |                            |
| <b>Fuel</b>   |             |                  |       |                                      |       |      |                            |
| Flexible lines and connections  |             | X                |       | R                                    |       |      | Quarterly                  |
| Main tank supply level  |             |                  | X     |                                      |       |      | Weekly                     |
| Fuel piping   |             | X                |       |                                      |       |      | Yearly                     |
| <b>Lubrication</b>  |             |                  |       |                                      |       |      |                            |
|   | 3.2         |                  |       |                                      |       |      |                            |
| Oil level   |             |                  | X     |                                      |       |      | 8 hours or before each use |
| Change oil  |             |                  |       | X                                    |       |      | Yearly or 150 hours        |
| Replace filter  |             |                  |       | X                                    |       |      | Yearly or 150 hours        |
| Crankcase breather hose   |             | X                |       |                                      |       |      | Yearly or 500 hours        |
| Oil cooler  |             | X                |       |                                      | X     |      | Yearly or 100 hours        |
| <b>Cooling</b>  |             |                  |       |                                      |       |      |                            |
|   | 3.5         |                  |       |                                      |       |      |                            |
| Air ducts, louvers  |             |                  | X     |                                      | X     |      | Yearly                     |
| <b>Exhaust System</b>   |             |                  |       |                                      |       |      |                            |
|   | 3.6         |                  |       |                                      |       |      |                            |
| Leakage   |             | X                | X     |                                      |       |      | Weekly                     |
| Insulation, fire hazards  |             | X                |       |                                      |       |      | Yearly                     |
| Obstructions or combustible materials near exhaust outlet   |             | X                |       |                                      |       |      | Weekly                     |
| <b>DC Electrical System</b>   |             |                  |       |                                      |       |      |                            |
|   | 3.7         |                  |       |                                      |       |      |                            |
| Battery charger operation, charge rate  |             | X                |       |                                      |       |      | Monthly                    |
| Remove corrosion, clean and dry battery and rack  |             | X                |       |                                      | X     |      | Yearly                     |
| Clean and tighten battery terminals and inspect boots   |             | X                | X     |                                      |       |      | Yearly                     |
| Battery electrolyte level and specific gravity *  |             |                  | X     |                                      |       |      | Yearly                     |
| <b>AC Electrical System</b>   |             |                  |       |                                      |       |      |                            |
| Tighten control and power wiring connections  |             |                  | X     |                                      |       |      | Yearly                     |
| Remote control system, if equipped  |             |                  |       |                                      |       | X    | Monthly                    |
| Visible wear or damage  |             | X                |       |                                      |       |      | Quarterly                  |
| Wire abrasions where subject to motion  |             | X                | X     |                                      |       |      | Six Months                 |
| Wire-cable insulation condition   |             | X                |       |                                      |       |      | 3 Years or 500 hours       |
| <b>Engine and Mounting</b>  |             |                  |       |                                      |       |      |                            |
| Visible wear or damage  |             | X                |       |                                      |       |      | Weekly                     |
| Air cleaner service †   | 3.4         |                  | 150   | 300                                  |       |      | Yearly or hours shown      |
| Spark plugs   | 3.3         |                  | 150   | 300                                  |       |      | Yearly or hours shown      |
| Replace stepper motor coupling and bushing  |             |                  |       | D                                    |       |      | 500 hours                  |
| <b>Generator</b>  |             |                  |       |                                      |       |      |                            |
| Visible wear or damage  |             | X                |       |                                      |       |      | Quarterly                  |
| Exercise generator set  |             |                  |       |                                      |       | W    | Weekly                     |
| Brushes and collector ring  |             | D                |       |                                      | D     |      | Yearly                     |
| Measure and record resistance readings of windings with insulation tester (Megger®, with SCR assembly or rectifier and load leads disconnected) |             |                  |       |                                      |       | D    | 3 Years                    |
| <b>General Condition of Equipment</b>   |             |                  |       |                                      |       |      |                            |
| Evidence of vibration, leakage, deterioration, unusual or excessive noise or temperature  |             | X                | X     |                                      | X     |      | Weekly                     |
| Interior of sound enclosure   |             | X                |       |                                      | X     |      | Quarterly                  |
| * Not necessary for maintenance-free batteries.   |             |                  |       | X = Action                           |       |      |                            |
| † Service more frequently under extremely dusty/dirty conditions.   |             |                  |       | D Authorized distributor/dealer only |       |      |                            |
| Megger® is a registered trademark of Biddle Instruments.  |             |                  |       | R Replace as necessary               |       |      |                            |

## 3.2 Lubrication System

See the service schedules in Section 3.1 for oil change and oil filter replacement intervals. See the service views in Section 1.6 for the oil drain, oil check, oil fill, and oil filter locations.

### 3.2.1 Low Oil Pressure Shutdown

The low oil pressure (LOP) shutdown feature protects the engine against internal damage if the oil pressure drops below a minimum pressure because of oil pump failure or other malfunction.

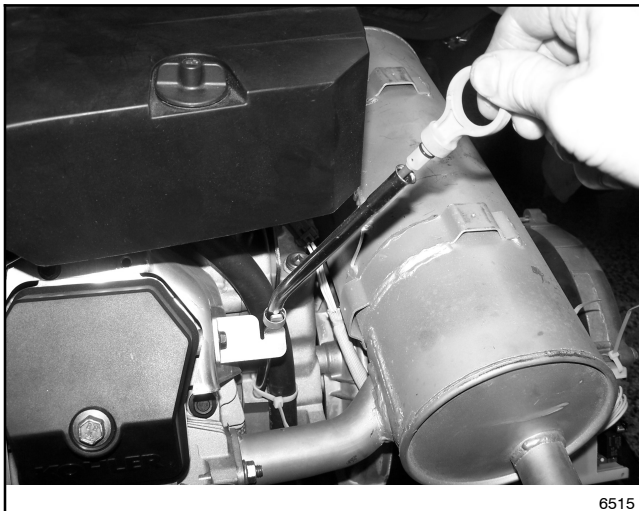
**Note:** The LOP shutdown feature does not protect against damage caused by operating when the oil level is low; it is not a low oil level shutdown. Check the oil level regularly, and add oil as needed.

### 3.2.2 Oil Check

The generator set is shipped with oil. Before operating the generator set, check the engine oil in the crankcase. See Figure 3-1.

Maintain the oil level at or near, not over, the full mark on the dipstick. Add 5W-30 synthetic oil when the oil level is low.

Check the oil level before each use. For extended operation, check the oil level every 8 hours. Do not check the oil level when the generator set is running. Shut down the generator set and wait several minutes before checking the oil.



**Figure 3-1** Oil Check (17/18 kW shown)

### 3.2.3 Engine Oil Recommendation

Use 5W-30 API (American Petroleum Institute) Service Class SG, SH, or SJ synthetic oil. Synthetic oil oxidizes and thickens less than other oils and leaves the engine intake valves and pistons cleaner.

### 3.2.4 Oil Change Procedure

**Note:** Dispose of all waste materials (engine oil, fuel, filter, etc.) in an environmentally safe manner.

Drain the oil while it is still warm.

#### 1. Drain the oil.

- a. Place the generator set master switch in the OFF position.
- b. Disconnect the power to the battery charger.
- c. Disconnect the generator set engine starting battery, negative (-) lead first.
- d. Remove the housing side panel.
- e. Clean the area around the dipstick and oil fill cap.
- f. Remove the oil drain hose from its retaining clip. Remove the cap from the oil drain hose and lower the hose into an oil collection container.
- g. Open the oil drain valve on the engine.
- h. Remove the dipstick and oil fill cap. Allow time for the engine oil to drain completely.
- i. Close the oil drain valve. Replace the cap on the oil drain hose. Replace the oil drain hose in its retaining clip.
- j. Replace the dipstick.

#### 2. Replace the oil filter.

- a. Clean the area around the oil filter. Remove the oil filter by rotating it counterclockwise with an oil filter wrench.
- b. Clean the gasket sealing surface of the oil filter adapter.
- c. Apply a light coat of clean oil to the rubber seal of the new oil filter.
- d. Install the new oil filter following the instructions provided with the filter.



### 3. Fill with oil.

- a. Fill the engine to the F mark on the dipstick. The engine oil capacity is shown in Figure 3-2. See Section 3.2.3, Engine Oil Recommendation, for oil selection.

| Generator Set | Oil Capacity, L (qt.) |
|---------------|-----------------------|
| 8.5/12RES     | 1.9 (2.0)             |
| 17/18RES      | 2.8 (3.0)             |

**Figure 3-2** Engine Oil Capacity

- b. Reinstall the dipstick and the oil fill cap.
- c. Check that the generator set master switch is in the OFF position.
- d. Reconnect the generator set engine starting battery, negative (-) lead last.
- e. Reconnect the power to the battery charger.
- f. Start and run the generator set for a minute to allow the oil pressure to reach operating range.
- g. Stop the generator set, wait 1 minute, and then recheck the oil level. Add oil to bring the level up to the F mark on the dipstick.

### 4. Check for leaks.

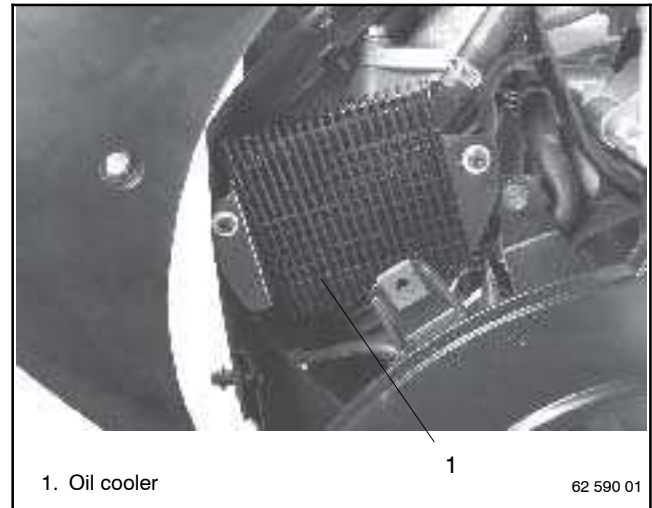
- a. Check for oil leaks.
- b. Fix leaks and recheck the oil level.
- c. Reinstall the housing side panel.

### 3.2.5 Oil Cooler, 17/18 kW

Inspect and clean the oil cooler at the intervals indicated in the service schedule. The oil cooler must be kept free of debris.

See Figure 3-3 for the oil cooler location. The oil cooler is located under the No. 2 cylinder shroud. Remove the top mounting screw and loosen the two side screws, then lift off the cylinder shroud.

Clean the outside of the oil cooler fins with a brush or with compressed air.



**Figure 3-3** Oil Cooler Location

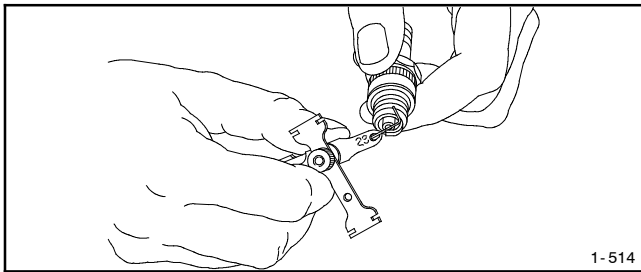
### 3.3 Spark Plugs

Reset the spark plug gap or replace the plugs with new plugs as necessary.

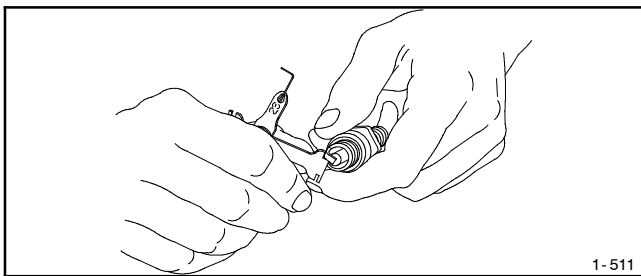
1. Clean the area around the base of the spark plug to keep dirt and debris out of the engine.
2. Remove the spark plug and check its condition. Replace the spark plug if it is worn or if its reuse is questionable.
3. Check the spark plug gap using a wire feeler gauge. See Figure 3-4 for the recommended spark plug gap. Adjust the gap by carefully bending the ground electrode. See Figure 3-5 and Figure 3-6.
4. Reinstall the spark plug into the cylinder head. Torque the spark plug to 24.4-29.8 Nm (18-22 ft. lb.)

| Generator Set | Spark Plug Gap      |
|---------------|---------------------|
| 8.5 kW        | 0.51 mm (0.020 in.) |
| 12/17/18RES   | 0.76 mm (0.030 in.) |

**Figure 3-4** Spark Plug Gap



**Figure 3-5** Checking the Spark Plug Gap

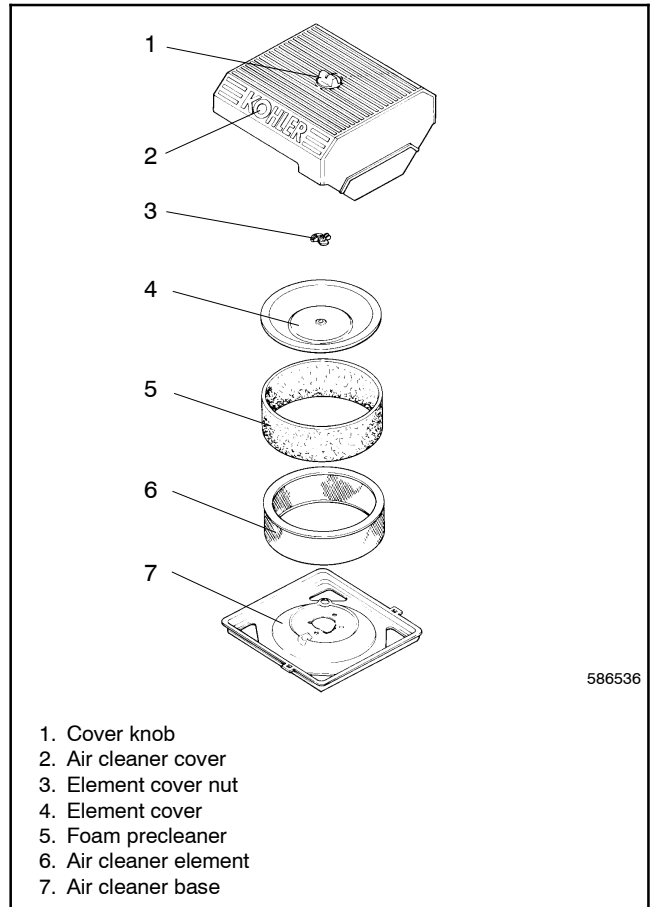


**Figure 3-6** Adjusting the Spark Plug Gap

### 3.4 Air Cleaner Service

#### 3.4.1 Air Cleaner, 8.5/12RES

The engine has a replaceable high-density paper air cleaner element with an oiled foam precleaner. See Figure 3-7.



**Figure 3-7** Air Cleaner Components

Check for a buildup of dirt and debris around the air cleaner system. Keep this area clean. Also check for loose or damaged components. Replace all bent or damaged air cleaner components.

**Note:** Operating the engine with loose or damaged air cleaner components could allow unfiltered air into the engine causing premature wear and failure.

#### Precleaner Service

Use the following procedure to wash and reoil the pre-cleaner as indicated in the service schedule. Wash and reoil the pre-cleaner more often under extremely dusty or dirty conditions.

1. Place the generator set master switch in the OFF/RESET position.

2. Disconnect the power to the battery charger.
3. Disconnect the battery, negative (-) lead first.
4. Loosen the cover retaining knob and remove the cover. Remove the precleaner from the paper element. Wash the precleaner in warm water with detergent. Rinse the precleaner thoroughly until all traces of detergent are eliminated. Squeeze out excess water (do not wring). Allow the precleaner to air dry.
5. Saturate the precleaner with new engine oil. Squeeze out all of the excess oil.
6. Reinstall the precleaner over the paper element.
7. Reinstall the air cleaner cover. Secure the cover with the cover retaining knob.
8. Reconnect the power to the battery charger.
9. Reconnect the generator set engine starting battery, negative (-) lead last.

### Paper Element Service

Use the following procedure to replace the paper element at the intervals specified in the service schedule. Replace the paper element more often under extremely dusty or dirty conditions.

1. Place the generator set master switch in the OFF/RESET position.
2. Disconnect the power to the battery charger.
3. Disconnect the generator set engine starting battery, negative (-) lead first.
4. Loosen the cover retaining knob and remove the cover.
5. Remove the element cover nut, element cover, and the paper element with precleaner.
6. Remove the precleaner from the paper element.
 

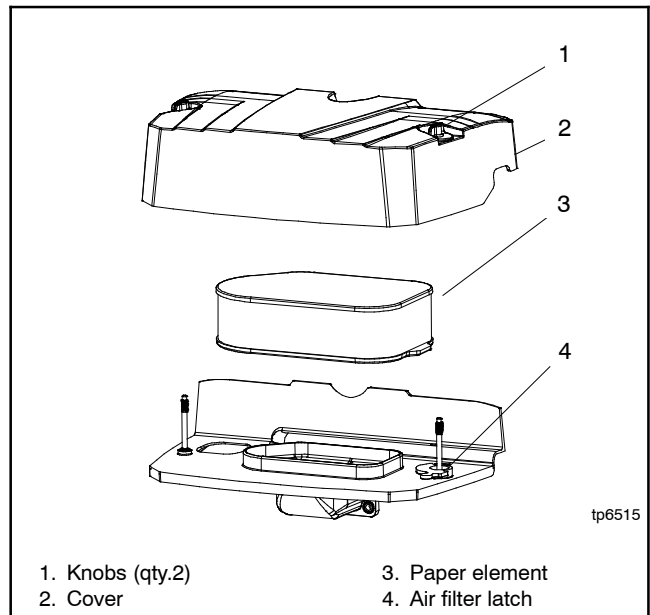
**Note:** Do not wash the paper element or clean it with pressurized air, as this will damage the element.
7. Replace the element if it is dirty, bent, or damaged.
8. Check the air cleaner base. Make sure it is secure and not bent or damaged. Also check the element cover for damage and fit. Replace all damaged air cleaner components. Remove any loose dirt or debris from the air cleaner base. Wipe the base carefully so that no dirt drops into the intake throat.

Check the condition of the rubber seal on the air cleaner stud and replace the seal if necessary.

9. Reinstall the paper element, precleaner, element cover, element cover nut, and the air cleaner cover. Secure the cover with the cover retaining knob.
10. Reconnect the power to the battery charger.
11. Reconnect the generator set engine starting battery, negative (-) lead last.

### 3.4.2 Air Cleaner, 17/18RES

The engine is equipped with a replaceable, high density paper air cleaner element. See Figure 3-8.



**Figure 3-8** Air Cleaner Components

Check the air cleaner daily or before starting the engine. Check for a buildup of dirt and debris around the air cleaner system. Keep this area clean. Also check for loose or damaged components. Replace all bent or damaged air cleaner components.

**Note:** Operating the engine with loose or damaged air cleaner components could allow unfiltered air into the engine causing premature wear and failure.

## Paper Element Service

Replace the paper element at the intervals indicated in the service schedule. See Section 3.1.2 for the service schedule. See Figure 3-8 for the air cleaner components.

1. Loosen the two cover retaining knobs and remove the cover.
2. Rotate the air filter latch counterclockwise to unlock, then remove the paper element.
3. Do not wash the paper element or use pressurized air, as this will damage the element. Replace a dirty, bent, or damaged element. Handle new elements carefully; do not use if the sealing surfaces are bent or damaged.
4. When servicing the air cleaner, check the air cleaner base and latch. Make sure it is secured and not bent or damaged. Also, check the element cover for damage or improper fit. Replace all damaged air cleaner components.

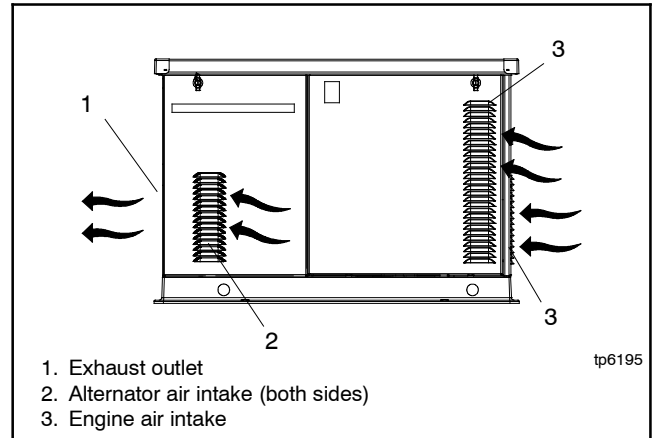
**Note:** If any loose dirt or debris fell on the air cleaner base when the element was removed, carefully remove it and wipe the base clean. Be careful that none of it drops into the intake throat.

5. Reinstall the paper element onto the air cleaner base. Make sure the element is flat and properly seated. Rotate the latch clockwise, over the molded lip on the element.
6. Install the air cleaner cover and secure with the two retaining knobs.
7. When element replacement is necessary, order genuine Kohler parts.

## 3.5 Cooling System

The engine fan draws cooling air through the openings in the sides and end near the battery. The alternator fan draws cooling air through openings on the side walls of the enclosure. The cooling air mixes with the engine exhaust and is discharged at the exhaust outlet. See Figure 3-9. To prevent generator set damage caused by overheating, keep the housing cooling inlets and outlets clean and unobstructed at all times.

**Note:** Do not block the generator set cooling air inlets or mount other equipment above them. Overheating and severe generator damage may occur.



**Figure 3-9** Cooling Air Intake and Exhaust

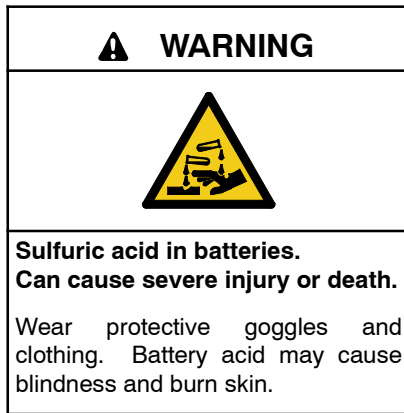
## 3.6 Exhaust System

Remove all combustible materials from the exhaust location. Combustible materials include building materials as well as natural surroundings. Keep dry field grass, foliage, and combustible landscaping material a minimum of 1.5 m (5 ft.) from the exhaust outlet.

Periodically inspect the exhaust system components for cracks, leaks, and corrosion.

- Check for corroded or broken metal parts and replace them as needed.
- Check that the exhaust outlet is clear.

## 3.7 Battery



**Battery electrolyte is a diluted sulfuric acid. Battery acid can cause severe injury or death.** Battery acid can cause blindness and burn skin. Always wear splashproof safety goggles, rubber gloves, and boots when servicing the battery. Do not open a sealed battery or mutilate the battery case. If battery acid splashes in the eyes or on the skin, immediately flush the affected area for 15 minutes with large quantities of clean water. Seek immediate medical aid in the case of eye contact. Never add acid to a battery after placing the battery in service, as this may result in hazardous spattering of battery acid.

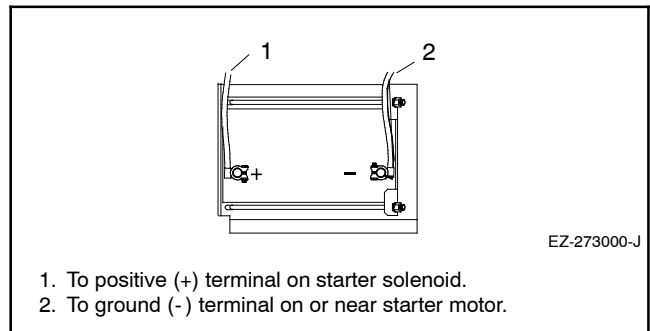
**Battery acid cleanup. Battery acid can cause severe injury or death.** Battery acid is electrically conductive and corrosive. Add 500 g (1 lb.) of bicarbonate of soda (baking soda) to a container with 4 L (1 gal.) of water and mix the neutralizing solution. Pour the neutralizing solution on the spilled battery acid and continue to add the neutralizing solution to the spilled battery acid until all evidence of a chemical reaction (foaming) has ceased. Flush the resulting liquid with water and dry the area.

**Battery gases. Explosion can cause severe injury or death.** Battery gases can cause an explosion. Do not smoke or permit flames or sparks to occur near a battery at any time, particularly when it is charging. Do not dispose of a battery in a fire. To prevent burns and sparks that could cause an explosion, avoid touching the battery terminals with tools or other metal objects. Remove all jewelry before servicing the equipment. Discharge static electricity from your body before touching batteries by first touching a grounded metal surface away from the battery. To avoid sparks, do not disturb the battery charger connections while the battery is charging. Always turn the battery charger off before disconnecting the battery connections. Ventilate the compartments containing batteries to prevent accumulation of explosive gases.

**Battery short circuits. Explosion can cause severe injury or death.** Short circuits can cause bodily injury and/or equipment damage. Disconnect the battery before generator set installation or maintenance. Remove all jewelry before servicing the equipment. Use tools with insulated handles. Remove the negative (-) lead first when disconnecting the battery. Reconnect the negative (-) lead last when reconnecting the battery. Never connect the negative (-) battery cable to the positive (+) connection terminal of the starter solenoid. Do not test the battery condition by shorting the terminals together.

Refer to this section for general battery information and maintenance. Also consult the battery manufacturer's instructions for battery maintenance.

All generator set models use a negative ground with a 12-volt engine electrical system. Consult the generator set nameplate for the engine electrical system voltage. Consult the generator spec sheet for battery capacity recommendations for replacement purposes. Wiring diagrams provide battery connection information. See Figure 3-10 for typical battery connections.



**Figure 3-10** 12-Volt Engine Electrical System Single Starter Motor, Typical Battery Connection

Clean the battery and cables and tighten battery terminals using the service schedule recommendations. To prevent corrosion, maintain tight, dry electrical connections at the battery terminals. To remove corrosion from battery terminals, disconnect the cables from the battery and scrub the terminals with a wire brush. Clean the battery and cables with a solution of baking soda and water. After cleaning, flush the battery and cables with clean water and wipe them with a dry, lint-free cloth.

After reconnecting the battery cables, coat the battery terminals with petroleum jelly, silicone grease, or other nonconductive grease.

## 3.8 Battery Charger

The generator set is equipped with a battery charger to maintain the engine starting battery. The charger's DC leads are factory-wired. Periodically check and tighten all connections.

See Section 2.8, Battery Charger.

### 3.9 Circuit Protection

If the generator set circuit breaker trips or the fuses blow repeatedly, see Section 4, Troubleshooting, for possible causes.

#### 3.9.1 Line Circuit Breaker

A line circuit breaker interrupts the generator output in the event of a fault in the wiring between the generator and the load. The line circuit breaker location is shown in Figure 1-3. The circuit breaker rating is shown in Figure 3-11. If the circuit breaker trips, reduce the load and switch the breaker back to the ON position. With the breaker in the OFF position the generator set runs but the generator output is disconnected from the load.

| Model    | Circuit Breaker Rating, Amp |
|----------|-----------------------------|
| 8.5RES   | 40                          |
| 12RES    | 50                          |
| 12TRES   | 20                          |
| 17/18RES | 80                          |
| 18TRES   | 25                          |

Figure 3-11 Line Circuit Breaker Rating

#### 3.9.2 Fuses

Three panel-mounted fuses protect the alternator and electrical controls. See Section 1.6 for fuse locations. Another 10-amp fuse protects the battery charger.

See Figure 3-12 for fuse part numbers. Always identify and correct the cause of a blown fuse before restarting the generator set. Refer to Section 4, Troubleshooting, for conditions that may indicate a blown fuse. Replace blown fuses with identical replacement parts.

| Fuse                  | Rating, Amp | Label | Part Number |
|-----------------------|-------------|-------|-------------|
| Auxiliary winding     | 20          | F1    | 292937      |
| Relay interface board | 10          | F2    | 223316      |
| Controller            | 10          | F3    | 223316      |
| Battery charger (RES) | 10          | —     | 223316      |

Figure 3-12 Fuses

## 3.10 Storage Procedure

Perform the following storage procedure before removing the generator set from service for three months or longer. Follow the engine manufacturer's recommendations for storage, if available.

**Note:** Run the generator set monthly whenever possible.

### 3.10.1 Lubricating System

1. Operate the generator set until it reaches operating temperature, or about 15 minutes.
2. Stop the generator set.
3. While the engine is still warm, drain the engine lubrication oil from the engine crankcase.
4. Refill engine crankcase with oil. See Section 3.2.3 for oil recommendations.
5. Run the generator set for a few minutes to distribute the clean oil.
6. Stop the generator set.

### 3.10.2 Fuel System

1. Start the generator set.
2. With the generator set running, shut off the gas supply.
3. Run the generator set until the engine stops.
4. Place the generator set master switch in the OFF/RESET position.

### 3.10.3 Cylinder Lubrication

1. Remove the spark plugs.
2. Pour one tablespoon of engine oil into each spark plug hole. Install the spark plugs and *ground* the spark plug leads. *Do not connect the leads to the plugs.*
3. Toggle the generator set master switch to crank the engine two or three revolutions to lubricate the cylinders.

### 3.10.4 Exterior Preparation

1. Clean the exterior surface of the generator set.
2. Seal all openings in the engine with nonabsorbent adhesive tape.
3. Mask all areas to be used for electrical contact.
4. Spread a light film of oil over unpainted metallic surfaces to prevent rust and corrosion.

### 3.10.5 Battery

Perform battery storage last.

1. Place the generator set master switch in the OFF/RESET position.
2. Disconnect the battery, negative (-) lead first.
3. Clean the battery.
4. Place the battery in a warm, dry location.
5. Connect the battery to a float/equalize battery charger, or charge the battery monthly using a trickle charger. Follow the battery charger manufacturer's recommendations.

# Notes



# Section 4 Troubleshooting

## 4.1 Introduction

Use the following charts to diagnose and correct common problems. First check for simple causes such as a dead engine starting battery, loose connections, or an open circuit breaker. The charts include a list of common problems, possible causes of the problem, and recommended corrective actions.

If the procedures in this manual do not explain how to correct the problem, contact an authorized distributor/dealer. Maintain a record of repairs and adjustments performed on the equipment. Use the record to help describe the problem and repairs or adjustments made to the equipment.

## 4.2 Controller Troubleshooting

Figure 4-1 contains troubleshooting, diagnostic, and repair information for the ADC-RES controller.

## 4.3 Generator Set Troubleshooting

Figure 4-2 contains generator set troubleshooting, diagnostic, and repair information. Check for loose connections before replacing parts.

### Fault Codes

The Advanced Digital Control displays fault codes to aid in troubleshooting. Fault codes, descriptions, and recommended actions are listed in Section 2.7.

If a fault code is displayed, identify and correct the cause of the fault condition. Then reset the controller. See Section 2.7.3.

| Problem                       | Possible Cause  | Corrective Action   |
|-------------------------------|---|---|
| Controller LED display is off | No power to the controller:<br>Controller fuse (F3) is blown.<br><br>Low or no battery voltage. | Replace the fuse. If the fuse blows again, contact an authorized distributor/dealer.<br><br>Check connections.<br>Check the engine starting battery and battery charger.<br>See Figure 4-3.   |
|                               | Generator set master switch is in the OFF/RESET position.                                       | Move generator set master switch to the AUTO or RUN position. In AUTO, the display will not turn on until the first start command is received.  |
|                               | The controller is in sleep mode. See Section 2.5.2.   | Controller display will activate when a remote start command is received or the generator set master switch is moved to the RUN position. Use the remote switch to start generator set and activate the controller display, if desired. See Section 2.5.<br><br>Controllers with application code version 1.13 or higher can be configured to enable or disable the sleep mode. See the generator set Installation Manual for instructions. |

Figure 4-1 ADC-RES Troubleshooting Chart

| <b>Problem</b>  | <b>Possible Cause</b>  | <b>Corrective Action</b>   |
|---|--|--|
| The generator set does not crank.   | Fault shutdown   | Check for a fault code on the controller display. See Section 2.7.                                   |
|   | Battery weak or dead   | Check power to the battery charger. Recharge or replace the battery.                                 |
|   | Battery charger fuse blown   | Replace the fuse. Contact an authorized distributor/dealer for service if fuse blows repeatedly.     |
|   | Battery connections reversed or poor   | Check the connections.   |
|   | Fuse F2 blown  | Replace the fuse. Contact an authorized distributor/dealer for service if fuse blows repeatedly.     |
|   | Fuse F3 blown  | Replace the fuse. Contact an authorized distributor/dealer for service if fuse blows repeatedly.     |
|   | Generator set master switch in the OFF position  | Move the master switch to AUTO for remote start or to RUN for local start.                           |
| The generator set cranks but does not start, starts hard, lacks power, or operates erratically. | Air cleaner clogged  | Clean and/or replace the air cleaner.  |
|   | Battery weak or dead   | Check power to the battery charger. Recharge or replace the battery.                                 |
|   | Battery connection poor  | Clean and tighten the battery connections.   |
|   | Spark plug wire connection loose   | Check the spark plug wires.  |
|   | Low oil pressure shutdown  | Check the oil level.   |
|   | Fuel pressure insufficient   | Check the fuel supply and valves.  |
|   | Engine malfunction   | Contact an authorized distributor/dealer.  |
| No AC output.   | AC circuit breaker in the OFF position   | Place the circuit breaker in the ON position.  |
|   | AC circuit breaker tripping because of overload  | Reduce the load on the generator set.  |
|   | AC circuit breaker tripping because of short circuit   | Contact an authorized distributor/dealer for service.  |
|   | Auxiliary winding fuse (F1) blown  | Replace the fuse. Contact an authorized distributor/dealer for service if fuse blows repeatedly.     |
| Low output or excessive drop in voltage.  | Generator set overloaded   | Reduce the load.   |
| Generator set stops suddenly.   | Low oil pressure shutdown  | Check the oil level. Check for signs of oil leaks.   |
|   | Out of fuel  | Check fuel supply.   |
|   | Overcrank shutdown   | Reset the controller. If the overcrank fault occurs again, contact an authorized distributor/dealer. |
|   | Controller fuse (F3) blown   | Replace the fuse. If the fuse blows again, contact an authorized distributor/dealer.                 |
|   | Overspeed shutdown   | Reset the controller. If the overspeed fault occurs again, contact an authorized distributor/dealer. |
|   | Generator set master switch in the OFF/RESET position  | Move the switch to the correct position (RUN or AUTO).   |
|   | Remote stop command received from a remote switch or ATS   | Check the remote switch position.  |
|   | Engine malfunction   | Contact an authorized distributor/dealer.  |
| Auxiliary winding fuse (F1) blown   | Replace the fuse. Contact an authorized distributor/dealer for service if fuse blows repeatedly. |  |

**Figure 4-2** General Troubleshooting Chart

## 4.4 Battery Charger Troubleshooting

Use the battery charger's LED indicators and the table in Figure 4-3 or Figure 4-4 to troubleshoot battery charger operation problems.

| Problem  | Cause   | Solution  |
|--|---|---|
| Red LED stays on for more than 24 hours                  | One or more inoperative or damaged cells.   | Load test the battery and replace, if necessary   |
|  | Battery charger has reduced its output voltage below the normal level due to a DC overload or a DC short. | Remove the source of the overload or short. Disconnect the battery charger's black (NEGATIVE) ring terminal from the battery. Reapply AC power and the green LED only should now light. |
|  | Onboard DC systems are drawing more current than the battery charger can replace.                         | Turn off all DC equipment while charging.   |
| Red and green LEDs stay on for more than 24 hours        | Onboard DC systems are drawing between 1.5 and 5 amps.  | Turn off all DC equipment while charging.   |
|  | One or more inoperative or damaged cells.   | Load test the battery and replace, if necessary   |
|  | Extremely low AC voltage at the battery charger.  | Apply a higher AC voltage source or reduce the length of the extension cord.  |
| Green LED stays on when the battery is known to be low   | Open DC output fuse.  | Replace AGS-10 fuse.  |
|  | Faulty or contaminated terminal connections.  | Clean and tighten or repair all terminal connections.   |
|  | One or more inoperative or damaged cells.   | Load test the battery and replace, if necessary.  |
| Neither of the LEDs turn on when the AC power is applied | No AC power available at the battery charger.   | Connect AC power or reset the AC breaker on the main panel.   |
|  | Component failure.  | Replace battery charger.  |

**Figure 4-3** 6-Amp Battery Charger Troubleshooting (for single-phase models)

| Problem  | Cause  | Solution  |
|--|--|---|
| Green LED is off and there is no output voltage.                       | No power to the battery charger.   | Check the power supply to the charger.<br>Check the upstream circuit breakers and fuses.<br>Check fuse FS (1A-T) inside the battery charger.  |
| Abnormal low voltage, charger is operating.                            | The battery completely discharged and the charger is operating at the current limit. | Disconnect the battery and verify that the charger output is 13.2 VDC.<br>Reconnect the charger and allow time for the battery to recharge. The battery voltage should rise gradually.<br>Test the battery. |
| The battery is discharged, but the charger has power and is operating. | Blown fuse.  | Check the 5-amp fuse F2 (5A-T) <i>inside</i> the battery charger and replace if necessary.<br>Check inline fuse F4 and replace if necessary.  |

**Figure 4-4** 2.5-Amp Battery Charger Troubleshooting (for three-phase models)

# Notes

# Appendix A Abbreviations

The following list contains abbreviations that may appear in this publication.

|           |  |                             |  |                      |  |
|-----------|--|-----------------------------|--|----------------------|--|
| A, amp    | ampere   | cfm                         | cubic feet per minute  | exh.                 | exhaust  |
| ABDC      | after bottom dead center   | CG                          | center of gravity  | ext.                 | external   |
| AC        | alternating current  | CID                         | cubic inch displacement  | F                    | Fahrenheit, female                                   |
| A/D       | analog to digital  | CL                          | centerline   | FHM                  | flat head machine (screw)                            |
| ADC       | advanced digital control;<br>analog to digital converter                                   | cm                          | centimeter   | fl. oz.              | fluid ounce  |
| adj.      | adjust, adjustment   | CMOS                        | complementary metal oxide<br>substrate (semiconductor)                               | flex.                | flexible   |
| ADV       | advertising dimensional<br>drawing   | com                         | communications (port)  | freq.                | frequency  |
| Ah        | amp-hour   | coml                        | commercial   | FS                   | full scale   |
| AHWT      | anticipatory high water<br>temperature   | Coml/Rec                    | Commercial/Recreational<br>connection  | ft.                  | foot, feet   |
| AISI      | American Iron and Steel<br>Institute   | conn.                       | connection   | ft. lb.              | foot pounds (torque)                                 |
| ALOP      | anticipatory low oil pressure  | cont.                       | continued  | ft./min.             | feet per minute                                      |
| alt.      | alternator   | CPVC                        | chlorinated polyvinyl chloride   | ftp                  | file transfer protocol                               |
| Al        | aluminum   | crit.                       | critical   | g                    | gram   |
| ANSI      | American National Standards<br>Institute (formerly American<br>Standards Association, ASA) | CSA                         | Canadian Standards<br>Association  | ga.                  | gauge (meters, wire size)                            |
| AO        | anticipatory only  | CT                          | current transformer  | gal.                 | gallon   |
| APDC      | Air Pollution Control District   | Cu                          | copper   | gen.                 | generator  |
| API       | American Petroleum Institute   | cUL                         | Canadian Underwriter's<br>Laboratories   | genset               | generator set  |
| approx.   | approximate, approximately   | CUL                         | Canadian Underwriter's<br>Laboratories   | GFI                  | ground fault interrupter                             |
| APU       | Auxiliary Power Unit   | cu. in.                     | cubic inch   | GND, ⊕               | ground   |
| AQMD      | Air Quality Management District  | cw.                         | clockwise  | gov.                 | governor   |
| AR        | as required, as requested  | CWC                         | city water-cooled  | gph                  | gallons per hour                                     |
| AS        | as supplied, as stated, as<br>suggested  | cyl.                        | cylinder   | gpm                  | gallons per minute                                   |
| ASE       | American Society of Engineers  | D/A                         | digital to analog  | gr.                  | grade, gross   |
| ASME      | American Society of<br>Mechanical Engineers  | DAC                         | digital to analog converter  | GRD                  | equipment ground                                     |
| assy.     | assembly   | dB                          | decibel  | gr. wt.              | gross weight   |
| ASTM      | American Society for Testing<br>Materials  | dB(A)                       | decibel (A weighted)   | H x W x D            | height by width by depth                             |
| ATDC      | after top dead center  | DC                          | direct current   | HC                   | hex cap  |
| ATS       | automatic transfer switch  | DCR                         | direct current resistance  | HCHT                 | high cylinder head temperature                       |
| auto.     | automatic  | deg., °                     | degree   | HD                   | heavy duty   |
| aux.      | auxiliary  | dept.                       | department   | HET                  | high exhaust temp., high<br>engine temp.             |
| avg.      | average  | dia.                        | diameter   | hex                  | hexagon  |
| AVR       | automatic voltage regulator  | DI/EO                       | dual inlet/end outlet  | Hg                   | mercury (element)                                    |
| AWG       | American Wire Gauge  | DIN                         | Deutsches Institut für Normung<br>e. V. (also Deutsche Industrie<br>Normenausschuss) | HH                   | hex head   |
| AWM       | appliance wiring material  | DIP                         | dual inline package  | HHC                  | hex head cap   |
| bat.      | battery  | DPDT                        | double-pole, double-throw  | HP                   | horsepower   |
| BBDC      | before bottom dead center  | DPST                        | double-pole, single-throw  | hr.                  | hour   |
| BC        | battery charger, battery<br>charging   | DS                          | disconnect switch  | HS                   | heat shrink  |
| BCA       | battery charging alternator  | DVR                         | digital voltage regulator  | hsg.                 | housing  |
| BCI       | Battery Council International  | E <sup>2</sup> PROM, EEPROM | electrically-erasable<br>programmable read-only<br>memory                            | HVAC                 | heating, ventilation, and air<br>conditioning        |
| BDC       | before dead center   | E, emer.                    | emergency (power source)   | HWT                  | high water temperature                               |
| BHP       | brake horsepower   | ECM                         | electronic control module,<br>engine control module                                  | Hz                   | hertz (cycles per second)                            |
| blk.      | black (paint color), block<br>(engine)   | EDI                         | electronic data interchange  | IBC                  | International Building Code                          |
| blk. htr. | block heater   | EFR                         | emergency frequency relay  | IC                   | integrated circuit                                   |
| BMEP      | brake mean effective pressure  | e.g.                        | for example ( <i>exempli gratia</i> )  | ID                   | inside diameter, identification                      |
| bps       | bits per second  | EG                          | electronic governor  | IEC                  | International Electrotechnical<br>Commission         |
| br.       | brass  | EGSA                        | Electrical Generating Systems<br>Association   | IEEE                 | Institute of Electrical and<br>Electronics Engineers |
| BTDC      | before top dead center   | EIA                         | Electronic Industries<br>Association   | IMS                  | improved motor starting                              |
| Btu       | British thermal unit   | EI/EO                       | end inlet/end outlet   | in.                  | inch   |
| Btu/min.  | British thermal units per minute   | EMI                         | electromagnetic interference   | in. H <sub>2</sub> O | inches of water                                      |
| C         | Celsius, centigrade  | emiss.                      | emission   | in. Hg               | inches of mercury                                    |
| cal.      | calorie  | eng.                        | engine   | in. lb.              | inch pounds  |
| CAN       | controller area network  | EPA                         | Environmental Protection<br>Agency   | Inc.                 | incorporated   |
| CARB      | California Air Resources Board   | EPS                         | emergency power system   | ind.                 | industrial   |
| CAT5      | Category 5 (network cable)   | ER                          | emergency relay  | int.                 | internal   |
| CB        | circuit breaker  | ES                          | engineering special,<br>engineered special   | int./ext.            | internal/external                                    |
| CC        | crank cycle  | ESD                         | electrostatic discharge  | I/O                  | input/output   |
| cc        | cubic centimeter   | est.                        | estimated  | IP                   | internet protocol                                    |
| CCA       | cold cranking amps   | E-Stop                      | emergency stop   | ISO                  | International Organization for<br>Standardization    |
| ccw.      | counterclockwise   | etc.                        | et cetera (and so forth)   | J                    | joule  |
| CEC       | Canadian Electrical Code   |                             |  | JIS                  | Japanese Industry Standard                           |
| cert.     | certificate, certification, certified  |                             |  | k                    | kilo (1000)  |
| cfh       | cubic feet per hour  |                             |  | K                    | kelvin   |
|           |  |                             |  | kA                   | kiloampere   |
|           |  |                             |  | KB                   | kilobyte (2 <sup>10</sup> bytes)                     |
|           |  |                             |  | KBus                 | Kohler communication protocol                        |
|           |  |                             |  | kg                   | kilogram   |

|                      |  |           |   |         |   |
|----------------------|--|-----------|---|---------|---|
| kg/cm <sup>2</sup>   | kilograms per square centimeter                      | NBS       | National Bureau of Standards                        | RTU     | remote terminal unit  |
| kgm                  | kilogram-meter                                       | NC        | normally closed                                     | RTV     | room temperature vulcanization  |
| kg/m <sup>3</sup>    | kilograms per cubic meter                            | NEC       | National Electrical Code                            | RW      | read/write  |
| kHz                  | kilohertz  | NEMA      | National Electrical Manufacturers Association       | SAE     | Society of Automotive Engineers                                       |
| kJ                   | kilojoule  | NFPA      | National Fire Protection Association                | scfm    | standard cubic feet per minute  |
| km                   | kilometer  | Nm        | newton meter  | SCR     | silicon controlled rectifier  |
| kOhm, kΩ             | kilo-ohm   | NO        | normally open                                       | s, sec. | second  |
| kPa                  | kilopascal   | no., nos. | number, numbers                                     | SI      | <i>Systeme international d'unites</i> , International System of Units |
| kph                  | kilometers per hour                                  | NPS       | National Pipe, Straight                             | SI/EO   | side in/end out   |
| kV                   | kilovolt   | NPSC      | National Pipe, Straight-coupling                    | sil.    | silencer  |
| kVA                  | kilovolt ampere                                      | NPT       | National Standard taper pipe thread per general use | SMTP    | simple mail transfer protocol   |
| kVAR                 | kilovolt ampere reactive                             | NPTF      | National Pipe, Taper-Fine                           | SN      | serial number   |
| kW                   | kilowatt   | NR        | not required, normal relay                          | SNMP    | simple network management protocol                                    |
| kWh                  | kilowatt-hour  | ns        | nanosecond  | SPDT    | single-pole, double-throw   |
| kWm                  | kilowatt mechanical                                  | OC        | overcrank   | SPST    | single-pole, single-throw   |
| kWth                 | kilowatt-thermal                                     | OD        | outside diameter                                    | spec    | specification   |
| L                    | liter  | OEM       | original equipment manufacturer                     | specs   | specification(s)  |
| LAN                  | local area network                                   | OF        | overfrequency                                       | sq.     | square  |
| L x W x H            | length by width by height                            | opt.      | option, optional                                    | sq. cm  | square centimeter   |
| lb.                  | pound, pounds  | OS        | oversize, overspeed                                 | sq. in. | square inch   |
| lbm/ft <sup>3</sup>  | pounds mass per cubic feet                           | OSHA      | Occupational Safety and Health Administration       | SMS     | short message service   |
| LCB                  | line circuit breaker                                 | OV        | overvoltage   | SS      | stainless steel   |
| LCD                  | liquid crystal display                               | oz.       | ounce   | std.    | standard  |
| LED                  | light emitting diode                                 | p., pp.   | page, pages   | stl.    | steel   |
| Lph                  | liters per hour                                      | PC        | personal computer                                   | tach.   | tachometer  |
| Lpm                  | liters per minute                                    | PCB       | printed circuit board                               | TB      | terminal block  |
| LOP                  | low oil pressure                                     | pF        | picofarad   | TCP     | transmission control protocol   |
| LP                   | liquefied petroleum                                  | PF        | power factor  | TD      | time delay  |
| LPG                  | liquefied petroleum gas                              | ph., ∅    | phase   | TDC     | top dead center   |
| LS                   | left side  | PHC       | Phillips® head Crimptite® (screw)                   | TDEC    | time delay engine cooldown  |
| L <sub>wa</sub>      | sound power level, A weighted                        | PHH       | Phillips® hex head (screw)                          | TDEN    | time delay emergency to normal  |
| LWL                  | low water level                                      | PHM       | pan head machine (screw)                            | TDES    | time delay engine start   |
| LWT                  | low water temperature                                | PLC       | programmable logic control                          | TDNE    | time delay normal to emergency  |
| m                    | meter, milli (1/1000)                                | PLC       | programmable logic control                          | TDOE    | time delay off to emergency   |
| M                    | mega (10 <sup>6</sup> when used with SI units), male | PMG       | permanent magnet generator                          | TDON    | time delay off to normal  |
| m <sup>3</sup>       | cubic meter  | pot       | potentiometer, potential                            | temp.   | temperature   |
| m <sup>3</sup> /hr.  | cubic meters per hour                                | ppm       | parts per million                                   | term.   | terminal  |
| m <sup>3</sup> /min. | cubic meters per minute                              | PROM      | programmable read-only memory                       | THD     | total harmonic distortion   |
| mA                   | milliampere  | psi       | pounds per square inch                              | TIF     | telephone influence factor  |
| man.                 | manual   | psig      | pounds per square inch gauge                        | tol.    | tolerance   |
| max.                 | maximum  | pt.       | pint  | turbo.  | turbocharger  |
| MB                   | megabyte (2 <sup>20</sup> bytes)                     | PTC       | positive temperature coefficient                    | typ.    | typical (same in multiple locations)                                  |
| MCCB                 | molded-case circuit breaker                          | PTO       | power takeoff                                       | UF      | underfrequency  |
| MCM                  | one thousand circular mils                           | PVC       | polyvinyl chloride                                  | UHF     | ultrahigh frequency   |
| meggar               | megohmmeter  | qt.       | quart, quarts                                       | UIF     | user interface  |
| MHz                  | megahertz  | qty.      | quantity  | UL      | Underwriter's Laboratories, Inc.                                      |
| mi.                  | mile   | R         | replacement (emergency) power source                | UNC     | unified coarse thread (was NC)  |
| mil                  | one one-thousandth of an inch                        | rad.      | radiator, radius                                    | UNF     | unified fine thread (was NF)  |
| min.                 | minimum, minute                                      | RAM       | random access memory                                | univ.   | universal   |
| misc.                | miscellaneous  | RDO       | relay driver output                                 | URL     | uniform resource locator (web address)                                |
| MJ                   | megajoule  | ref.      | reference   | US      | undersize, underspeed   |
| mJ                   | millijoule   | rem.      | remote  | UV      | ultraviolet, undervoltage   |
| mm                   | millimeter   | Res/Coml  | Residential/Commercial                              | V       | volt  |
| mOhm, mΩ             | milliohm   | RFI       | radio frequency interference                        | VAC     | volts alternating current   |
| MOhm, MΩ             | megohm   | RH        | round head  | VAR     | voltampere reactive   |
| MOV                  | metal oxide varistor                                 | RHM       | round head machine (screw)                          | VDC     | volts direct current  |
| MPa                  | megapascal   | rly.      | relay   | VFD     | vacuum fluorescent display  |
| mpg                  | miles per gallon                                     | rms       | root mean square                                    | VGA     | video graphics adapter  |
| mph                  | miles per hour                                       | rnd.      | round   | VHF     | very high frequency   |
| MS                   | military standard                                    | RO        | read only   | W       | watt  |
| ms                   | millisecond  | ROM       | read only memory                                    | WCR     | withstand and closing rating  |
| m/sec.               | meters per second                                    | rot.      | rotate, rotating                                    | w/      | with  |
| mtg.                 | mounting   | rpm       | revolutions per minute                              | WO      | write only  |
| MTU                  | Motoren-und Turbinen-Union                           | RS        | right side  | w/o     | without   |
| MW                   | megawatt   | RTDs      | Resistance Temperature Detectors                    | wt.     | weight  |
| mW                   | milliwatt  |           |   | xfrm    | transformer   |
| μF                   | microfarad   |           |   |         |   |
| N, norm.             | normal (power source)                                |           |   |         |   |
| NA                   | not available, not applicable                        |           |   |         |   |
| nat. gas             | natural gas  |           |   |         |   |

## Notes

**TP-6515 2/21g**

© 2007 Kohler Co. All rights reserved.

**KOHLER®**

KOHLER CO., Kohler, Wisconsin 53044  
Phone 920-457-4441, Fax 920-459-1646  
For the nearest sales/service outlet in the  
US and Canada, phone 1-800-544-2444  
[KOHLERPower.com](http://KOHLERPower.com)