



Features

- Integral flange.
- Left drain.
- Slotted overflow for deep soaking.
- VibrAcoustic® technology emits sound waves and offers a surround sound experience.
- Six transducers and a control amplifier with 25' (7.6 m) of wiring.
- High-resolution color screen in polished chrome.
- Integral apron with removable access panel.
- Integral lumbar support and armrests for comfort.
- Coordinates with other products in the Archer® collection.
- 66" (1676 mm) x 32" (813 mm) x 19" (483 mm)

Material

- Acrylic

Installation

- Alcove
- Syncs with devices enabled with BLUETOOTH® wireless technology including smart phones, MP3 players, tablets and laptops located up to 33 feet away.*

Required Accessories

K-7271 Brass Slotted Overflow Bath Drain

or

K-7272 PVC Slotted Overflow Bath Drain



ADA

Codes/Standards

CSA B45.5/IAPMO Z124
UL 1795
CSA C22.2 No. 218.2
Greenguard UL 2818 - Gold
ADA
ICC/ANSI A117.1
CARB P2

KOHLER® One-Year Limited Warranty

See website for detailed warranty information.

*The BLUETOOTH® word mark and logos are registered trademarks owned by Bluetooth SIG, Inc. and any use of such marks by Kohler Co. is under license. Other trademarks and trade names are those of their respective owners.

Available Color/Finishes

Color tiles intended for reference only.

Color	Code	Description
	0	White
	96	Biscuit
	47	Almond
	NY	Dune
	95	Ice™ Grey
	G9	Sandbar
	33	Mexican Sand™
	K4	Cashmere

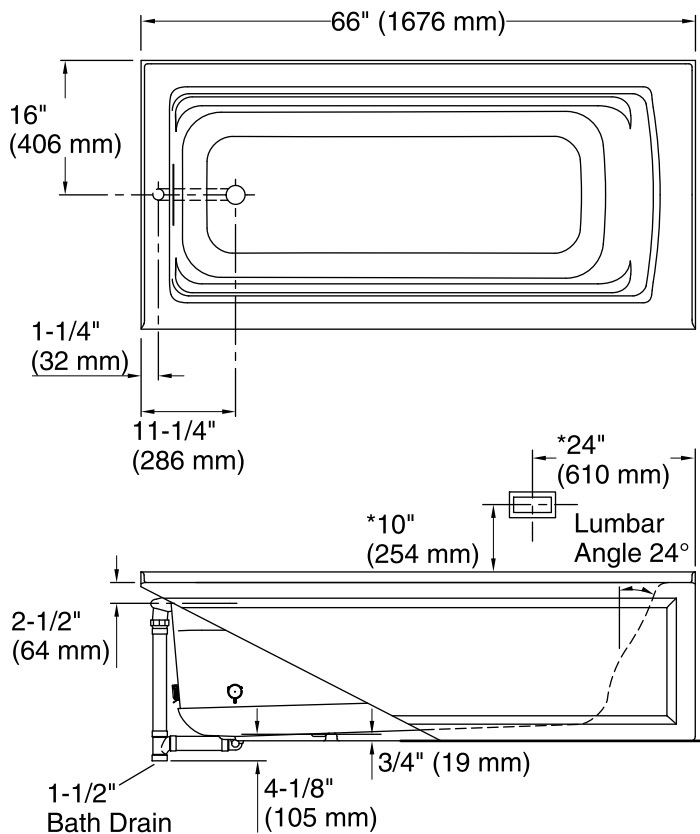

No change in measurements if connected with drain illustrated. (K-7272)

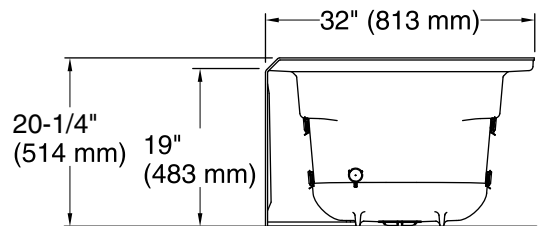
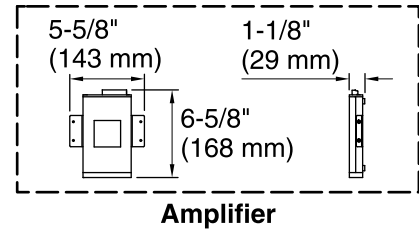
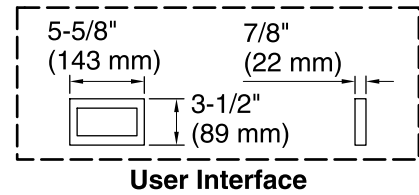
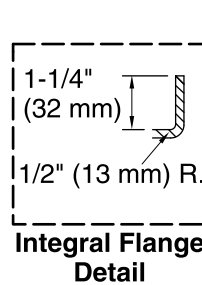

Required Electrical Service

One circuit required, protected with Class A Ground-Fault Circuit-Interrupter (GFCI) or Residual Current Device (RCD).

Amplifier: 120 V, 15 A, 50/60 Hz

Technical Information

All product dimensions are nominal.

Installation: 3-Wall Alcove

Drain location: Left

Basin area, bottom: 50-3/8" x 19-5/8" (1280 mm x 498 mm)

Basin area, top: 57-5/16" x 24-1/16" (1456 mm x 611 mm)

Weight: 83 lbs (37.6 kg)

Minimum floor load: 45 lbs/ft² (219.7 kg/m²)

Water depth: 15-5/16" (389 mm)

Water capacity: 66 gal (249.8 L)

Electrical component rating: Amplifier: 120 V, 1.1 A, 50/60 Hz

Amplifier channels: 2 at 15 W per channel
 2 at 30 W per channel

Minimum flat for door: 2-3/16" (55 mm)

Notes

Measure your actual product for rough-in details.

Install this product according to the installation instructions.

Control amplifier fits 16" (406 mm) center studs. 25' (7.6 m) cables are included.

ADA compliant when installed to the specific requirements of these regulations.