

CAUTION

WHEN INSTALLING KICHLER® LANDSCAPE LIGHTING (LINE VOLTAGE OR LOW VOLTAGE), CARE SHOULD BE TAKEN TO KEEP CLEAR OF POTENTIALLY COMBUSTIBLE MATERIALS. FIXTURES SHOULD NOT BE MOUNTED ON OR ADJACENT TO COMBUSTIBLE MATERIALS. WHEN MAINTAINING THE FIXTURES, BE SURE TO REMOVE LEAVES, PINE NEEDLES, GRASS CLIPPINGS, MULCH, OR ANY DEBRIS THAT HAS ACCUMULATED ON THE LIGHT BULB, LENS, OR BODY OF THE FIXTURE.

ASSEMBLY AND INSTALLATION

- Installation should be done by a qualified electrician in accordance with local, state and national electric codes.
- Excavation for conduit and conduit runs should be completed before proceeding.
- If installing fixture in concrete using Kichler pour kit 15608AZ (sold separately) follow directions included with pour kit and skip steps 3,5 and 6.

- 1) Turn off power.
- 2) Remove retaining ring, glass and yoke assembly.
- 3) At desired location, dig hole approximately 3" larger in diameter and depth than well light.
- 4) Attach conduit to bottom of well light. To avoid water from entering well light, thread sealant should be used. NOTE: Bottom of well light has two holes for connection of conduit. Hole not being used should be plugged using plug provided. Conduit connector may be torqued to a maximum 16 ft. lb (200 in. lb) for 12.7mm (1/2 in.) opening or 36 ft. lb (432 in. lb) for 19mm (3/4 in.) opening.
- 5) Fill bottom of hole with approximately 3" of pea gravel or equivalent granular material. Top edge of well light should be at or slightly above finish grade. Adjust by adding or removing material.
- 6) Back fill area between well light and hole with pea gravel or equivalent granular material.
- 7) Completely seal conduit connections inside well light using provided gel encapsulate.
- 8) Connect supply wires to ballast leads (wire connectors not included). Fixture is supplied with a quad-tap ballast, make connections as shown below. Supply hot lead must be connected to proper ballast tap or damage to ballast may occur.

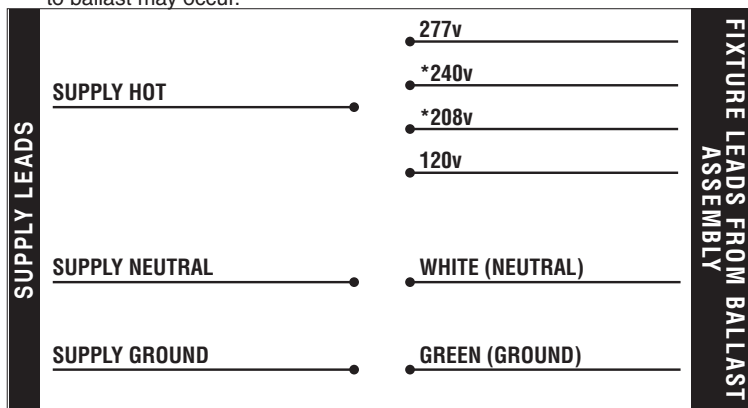

- 9) Adjust angle for bulb by loosening wing nuts inside yoke assembly and adjust bottom end of yoke. Once at desired angle tighten wing nuts.
- 10) Slip yoke assembly into well light and secure in place with screws. *NOTE: Reflector must be used with ED17 lamp. When using PAR 30/38 lamp, remove reflector.
- 11) Insert recommended lamp. Lamp strike time may vary from instantaneous to 5 minutes depending upon lamp/manufacturer used.
- 12) Insure that all gasket seating surfaces and screw holes are free and clear of debris. If screw holes are not clear blow debris out or clear with #10-32 tap.
- 13) Slip glass with gasket into well light.
- 14) Slip screws previously removed in step 2 through holes in retaining ring.
- 15) Align screws with holes in well light and tighten using an alternating torque sequence at 20-30 inch-lbs. (SEE ILLUSTR. – Numbers indicate order in which to tighten screws.)

* Input voltages of 208v. and 240v. not for use in Canada.

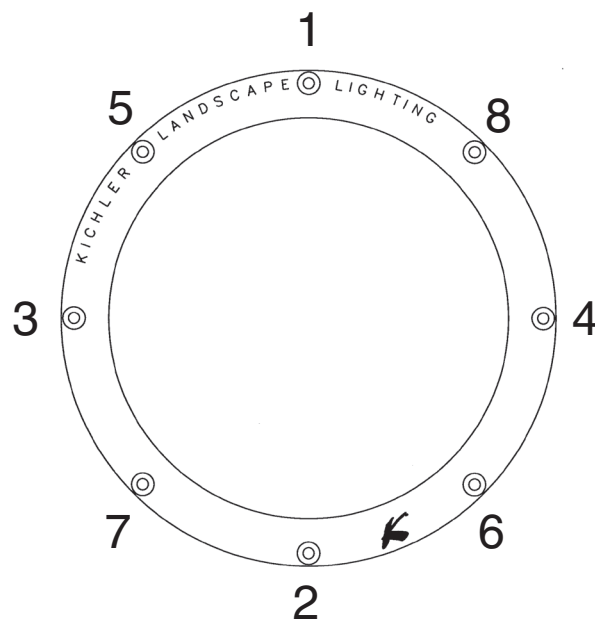
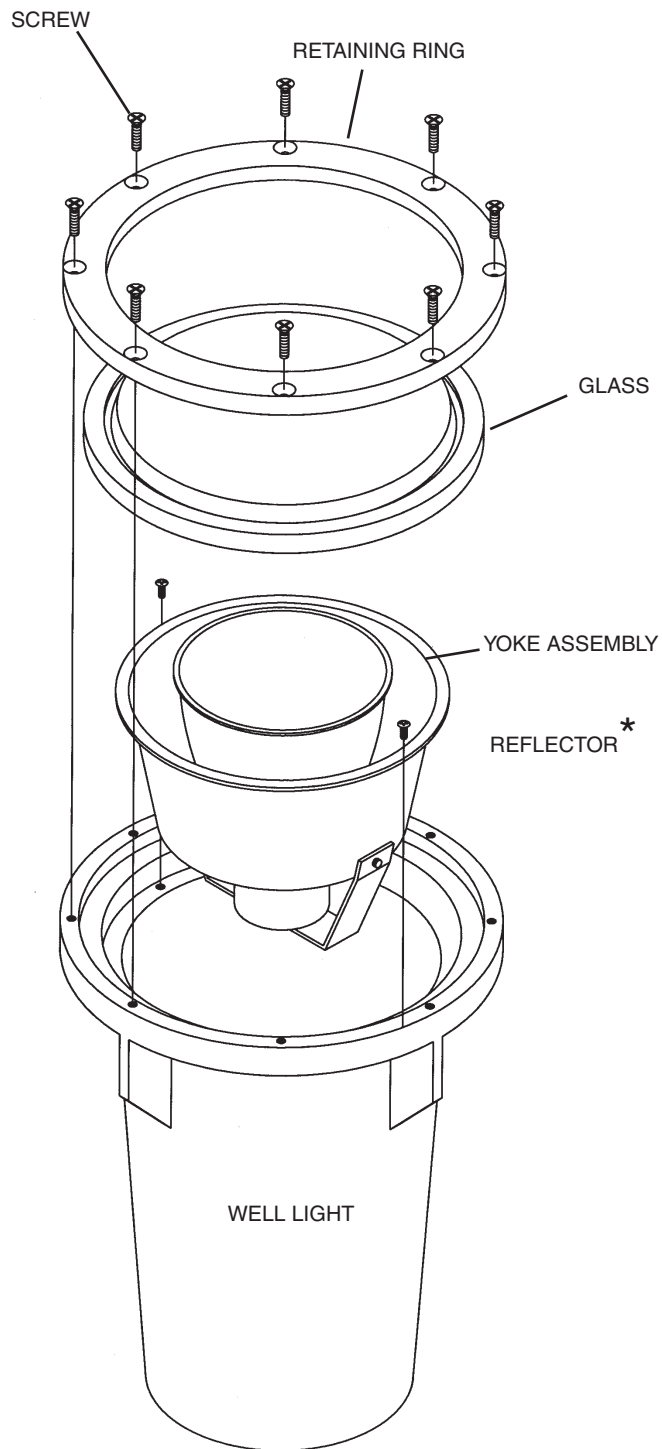

WARRANTY

WE WARRANT THE LANDSCAPE PRODUCTS FEATURED IN OUR LANDSCAPE LIGHTING CATALOG (WITH THE EXCEPTION OF LIGHT BULBS) FOR FIVE YEARS AGAINST DEFECTS IN MATERIALS AND WORKMANSHIP IF IT WAS PROPERLY INSTALLED AND FAILED UNDER NORMAL OPERATING CONDITIONS, PROVIDED IT IS RETURNED TO THE POINT OF PURCHASE, WHERE IT WILL BE REPAIRED OR, AS IT MAY BE DETERMINED, TO REPLACE THE LANDSCAPE PRODUCT OR PARTS USED ON THAT PRODUCT.