

FEATURES

- Variable speed pump
- Bath mounted electronic control with feedback
- Additional remote control
- In-line water heater
- Cast iron construction

CODES/STANDARDS APPLICABLE

Specified model meets or exceeds the following:

- ADA
- ASME A112.19.7/CSA B45.10
- ASME A112.19.1/CSA B45.2
- CSA C22.2 No 218.2
- ICC/ANSI A117.1
- UL 1795

**P50014-H2,
P50014-BA**

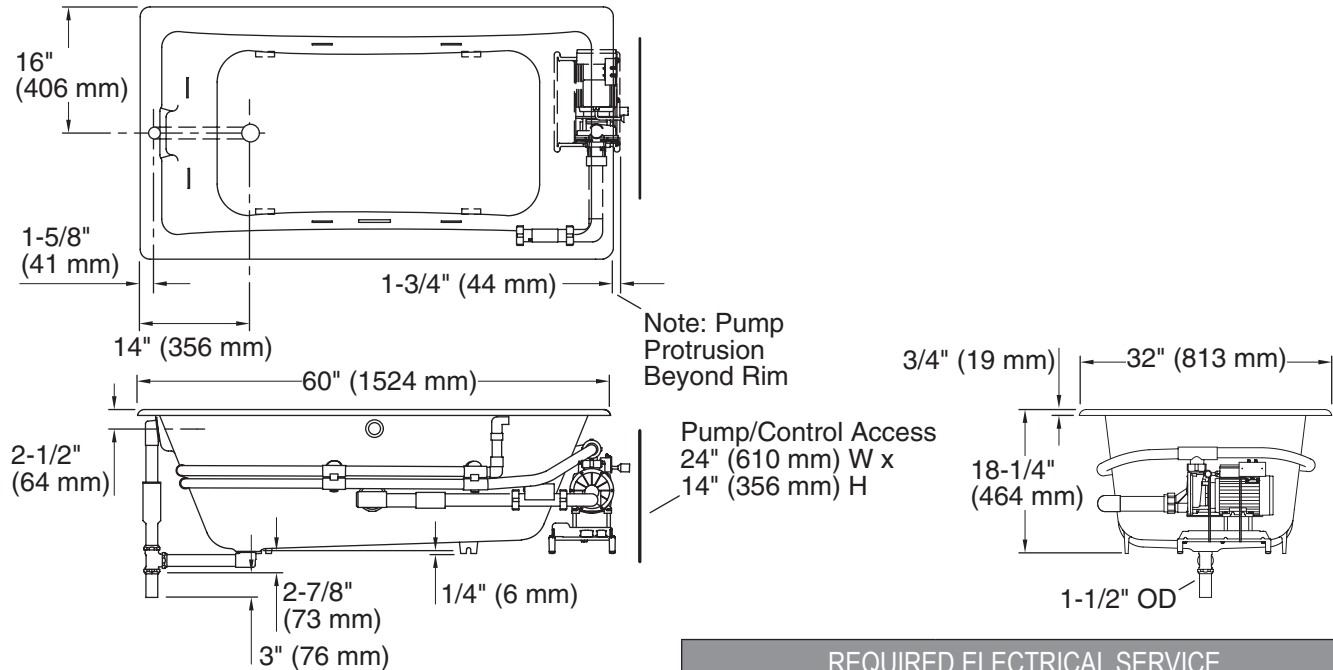

PRODUCT INFORMATION			
Fixture*:	Top Area	Inside Area	Weight
Bathing Well	40-1/2" (1029 mm) x 20" (508 mm)	54" (1372 mm) x 24" (610 mm)	290 lbs (131.5 kg)
	Water Depth	Capacity	
To Overflow	13-5/8" (346 mm)	60 gal (227.1 L)	
*Approximate measurements for comparison only.			
Heater	Voltage	Frequency	Amperage
1.5 kW	240 V	50/60 Hz	11 A

REQUIRED ELECTRICAL SERVICE	
Dedicated circuit required, protected with Class A Ground-Fault Circuit-Interrupter (GFCI) or Residual Current Device (RCD):	
Pump/Control:	220-240 V, 20 A, 50/60 Hz

ROUGHING-IN NOTES	
No change in measurements if connected with drain illustrated.	
Drop-in Cutout	58-1/2" (1486 mm) x 30-1/2" (775 mm)
Floor support under whirlpool must provide for a minimum of 60 lbs/square foot (290 kg/square meter) loading.	
Hot water supply must be 70% of capacity or greater.	

SPECIFIED MODEL			
Model	Description	Finishes	
P50014-H2	Barbara Barry Whirlpool	<input type="checkbox"/> 0 Stucco White	<input type="checkbox"/> 96 Linen
P50014-BA	Barbara Barry Bath	<input type="checkbox"/> 0 Stucco White	<input type="checkbox"/> 96 Linen
Required Accessories (Pick One)			
P21573-00	Barbara Barry Waste and Overflow	<input type="checkbox"/> CP Polished Chrome	<input type="checkbox"/> AD Nickel Silver <input type="checkbox"/> AG Brushed Nickel
P21575-00	Standard Waste and Overflow	<input type="checkbox"/> CP Polished Chrome	<input type="checkbox"/> AD Nickel Silver <input type="checkbox"/> AG Brushed Nickel
Optional Accessories			
P51002-00	Whirlpool Trim Kit, 6-Jet	<input type="checkbox"/> CP Polished Chrome	<input type="checkbox"/> AD Nickel Silver <input type="checkbox"/> AG Brushed Nickel

We reserve the right to make revisions without notice in the design of products or in packaging unless this right has specifically been waived at the time the order is accepted.