

KALLISTA® & Pressure Balance Valve Trim with Diverter

For Town Pressure Balance Valve Trim

FEATURES

- Solid Brass Construction for Durability and Reliability
- Pressure-Balancing Technology Maintains Water Temperature within +/-3 Degrees Fahrenheit
- High-Temperature Limit Stop Helps Eliminate Scalding
- Coordinates with the For Town Collection

CODES/STANDARDS APPLICABLE

- Specified model meets or exceeds the following:
- ASME A112.18.1/CSA B125.1

P22715,
P22716

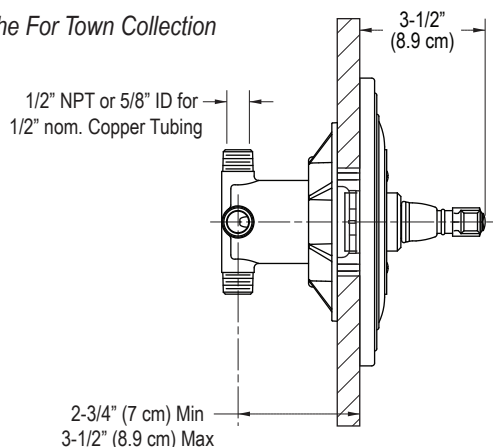

P22715

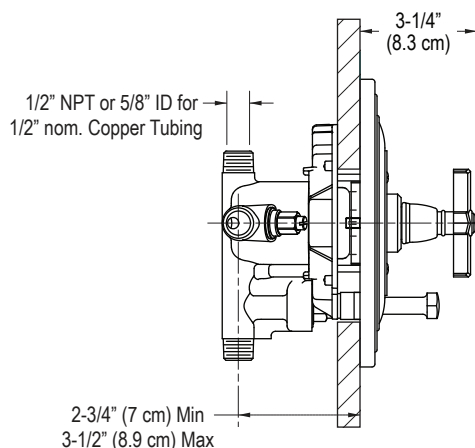
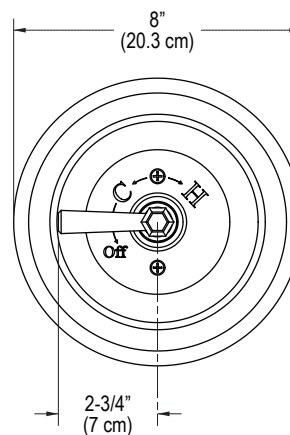

P22716

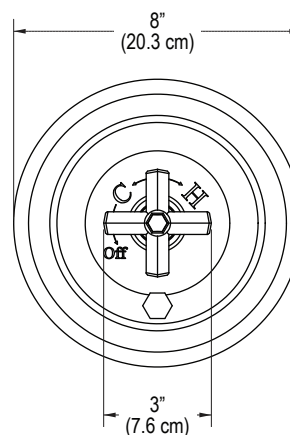

SPECIFIED MODEL

Model	Description	Finishes		
P22715-XX	For Town Pressure Balance Valve Trim, Cross Handle	<input type="checkbox"/> CP Polished Chrome	<input type="checkbox"/> AD Nickel Silver	<input type="checkbox"/> AG Brushed Nickel
P22715-LX	For Town Pressure Balance Valve Trim, Lever Handle	<input type="checkbox"/> CP Polished Chrome	<input type="checkbox"/> AD Nickel Silver	<input type="checkbox"/> AG Brushed Nickel
P22716-XX	For Town Pressure Balance Valve Trim with Diverter, Cross Handle	<input type="checkbox"/> CP Polished Chrome	<input type="checkbox"/> AD Nickel Silver	<input type="checkbox"/> AG Brushed Nickel
P22716-LX	For Town Pressure Balance Valve Trim with Diverter, Lever Handle	<input type="checkbox"/> CP Polished Chrome	<input type="checkbox"/> AD Nickel Silver	<input type="checkbox"/> AG Brushed Nickel
Required Rough-in				
P19300-00	Rough-in for P22715	<input type="checkbox"/> NA		
P19300-WS	Rough-in with Stops for P22715	<input type="checkbox"/> NA		
P29306-WS	High-Flow Rough-in for P22715	<input type="checkbox"/> NA		
P29305-00	Rough-in for P22716	<input type="checkbox"/> NA		
P29305-WS	Rough-in with Stops for P22716	<input type="checkbox"/> NA		

We reserve the right to make revisions without notice in the design of products or in packaging unless this right has specifically been waived at the time the order is accepted.