

FEATURES

- Solid metal construction for durability and reliability
- Pressure-balancing technology maintains water temperature within +/- 3 degrees Fahrenheit
- High-temperature limit stop allows you to preset a comfortable maximum temperature to eliminate scalding
- Complements the Per Se collection

CODES/STANDARDS APPLICABLE

Specified model meets or exceeds the following:

- ASME A112.18.1/CSA B125.1
- ICC/ANSI A117.1
- ADA* (pending)
- OBC* (pending)
- CSA B651* (pending)

ADA **CSA B651** **OBC**

* Compliant when installed to the specific requirement of this regulation

P24715

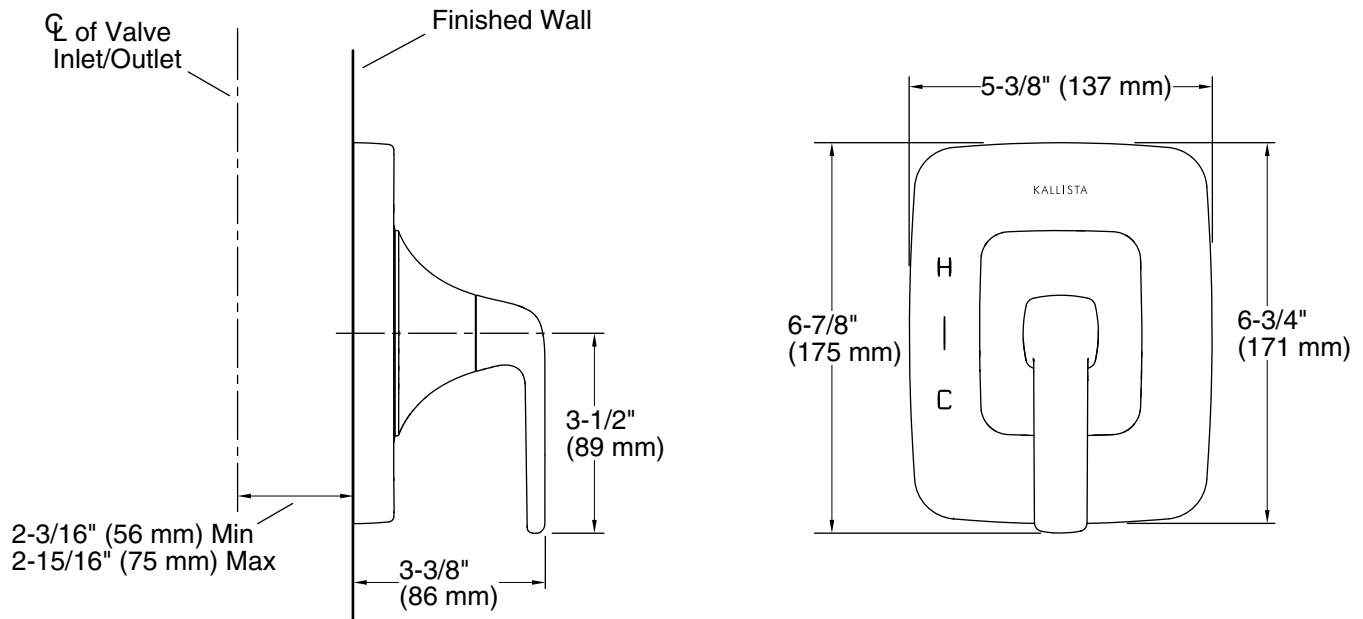

SPECIFIED MODEL						
Model	Description	Finishes				
P24715-LV	Per Se Pressure Balance Valve Trim, Lever Handle	<input type="checkbox"/> CP Polished Chrome	<input type="checkbox"/> AD Nickel Silver	<input type="checkbox"/> AG Brushed Nickel	<input type="checkbox"/> W7 Black Nickel	<input type="checkbox"/> 24K Polished Gold
Required Rough-In						
P19310-00	Pressure Balance Valve	<input type="checkbox"/> NA				
P19310-US	Pressure Balance Valve, with stops - PEX inlet (cold expansion)	<input type="checkbox"/> NA				
P19310-WS	Pressure Balance Valve, with stops	<input type="checkbox"/> NA				

We reserve the right to make revisions without notice in the design of products or in packaging unless this right has specifically been waived at the time the order is accepted.