

Kalamazoo Gaucho Grill

USE AND CARE GUIDE



Important Safety Warnings

This appliance is FOR OUTDOOR USE ONLY. It is not to be used inside a garage, other building or any type of enclosed area.

WARNING: Failure to follow the information in this Use and Care Guide exactly may result in fire or explosion, causing property damage, personal injury or death. Read and follow all warnings and instructions before assembling and using the appliance.

WARNING: This appliance is not intended to be installed in or on a boat or recreational vehicle.



DANGER: IF YOU SMELL GAS:

1. Shut-off gas to the appliance.
2. Extinguish any open flame.
3. Remove grill cover.
4. If odor continues, keep away from the appliance and immediately call your gas supplier or fire department.

Failure to follow these instructions could result in fire or explosion which could cause property damage, personal injury or death.



WARNING: FOR YOUR SAFETY:

1. Do not store or use gasoline or other flammable liquids or vapors in the vicinity of this or any other appliance.
2. An LP cylinder not connected for use shall not be stored in the vicinity of this or any other appliance.

IMPORTANT: Damage caused by a failure to heed the warnings or follow the safety instructions and practices described in this Use and Care Guide is not covered by the warranty.

This Use and Care Guide contains important information necessary for the proper assembly and safe use of the grill.

Read and follow all warnings and instructions before assembling and using the grill.

Follow all warnings and instructions when using the grill.

Keep the Use and Care Guide for future reference.



Version 24.10.2017

Thank you for choosing Kalamazoo Outdoor Gourmet cooking equipment.

Because of the high performance nature and unique design of Kalamazoo grills, we recommend familiarizing yourself with this book before using your grill for the first time. Your *Use and Care Guide* contains important safety information as well as helpful guidance for successful cooking experiences and care. Following the guidance of this book will help ensure many years of outdoor cooking enjoyment.

Should you ever have any questions about cooking with or caring for your Kalamazoo grill, we are here to help. Contact Kalamazoo Outdoor Gourmet Customer Service at:

1.800.868.1699

or

customerservice@KalamazooGourmet.com

Please have your model number and serial number ready or include it in your email.

Model Number

K750GB K750GT K750GS

Fuel Type

Natural Gas Liquid Propane Bulk Liquid Propane

Serial Number

Table of Contents

Safe Operation	2
Liquid Propane Tank Safety	4
Gas Requirements	6
Leak Testing	9
Locating the Grill	10
Required Clearances	10
Grill Dimensions	11
Initial Assembly	14
Get to Know Your Grill	16
Grill Controls	22
Lighting Your Grill	24
Ignition System Power Supply	26
Burner Adjustments	27
Valve Adjustments	28
Cooking with Your Grill	29
Food Temperature Chart	31
Caring for Your Grill	32
Troubleshooting	34
Electrical Diagrams	36
Installation Checklist	40

Safe Operation

WARNING: When in use, portions of your grill get hot enough to cause severe burns. Children and pets should never be left alone or unattended in the area where the grill is being used. Never allow children to sit, stand or play on or around the grill. Do not allow someone operate the grill if they have not read this manual.

IMPORTANT: Improper use or installation is dangerous. Because this grill produces intense heat, the risk of accidents or potential injuries is increased. Extreme care must be taken.

Carefully follow all instructions, including the following:

- To reduce the risk of fire, burns or other injury, read this Use and Care Guide thoroughly. Begin by ensuring proper installation and servicing. Do not repair or replace any part of the grill yourself unless it is specifically recommended in this Use and Care Guide. All other service must be carried out by a qualified gas technician.
- Never allow children to operate the grill. Do not store items of interest to children in or around the grill.
- Do not heat unopened food containers in the grill. The build up of pressure resulting from the heat may cause the container to burst.
- Never lean on any part of the grill.
- When lighting the grill, always pay close attention to what you are doing. Make sure you are aware of which burner you are lighting and can see whether or not it is lit. Make sure you have ready access to the burner valves when you are lighting the burner. Make sure you are pushing in the burner valve to activate the ignition when you attempt to light the burner.
- When the burners are on or the grill is hot, do not touch the grilling surface, grill rack, upper structure, any part of the grill's interior or any surface of areas surrounding the grilling surface. These areas become extremely hot and may cause severe burns. Do not touch any surface of the fire box that can be accessed within the cabinet below the grill. Do not touch or operate the chute closure or ash cleanout bin.
- The cabinet below the grill is not for storage. It is for service access and cleaning. Do not store combustible materials in the cabinet below the grill. Likewise, do not store items made with materials that might melt or otherwise be damaged by heat.
- Do not use any cleaner, including water, on a hot grill.
- Be sure all control knobs are in the OFF position and the grill is cool before using any aerosol cleaner on it or near it. The chemical used for aerosol propellant could ignite in the presence of heat.
- Do not burn manufactured logs, driftwood, trash, leaves, paper, cardboard, plywood, painted or stained or pressure treated wood. Avoid using softwoods such as pine or cedar that can throw sparks.
- Do not use near or under overhanging trees and shrubs.
- Do not use in windy conditions.
- Do not operate the grill under overhead combustible construction. Use only in a well-ventilated area. The grill is for outdoor use only.
- Do not leave the fire unattended.
- Always wait at least 24 hours after the last time the grill was hot before emptying the ash bin.

Safe Operation CONTINUED

- Always use dry pot holders or gloves on hot surfaces or cooking tools: moist or damp pot holders or gloves may cause steam burns. Never use a towel or bulky cloth in place of pot holders. Do not let pot holders touch hot portions of the grill or allow them to get near the open flame.
- Do not obstruct any of the openings on the grill or otherwise obstruct the flow of combustion and ventilation air.
- Do not build the grill into any combustible structure that is closer than 12 inches from the sides and back below the body of the grill, or 36 inches from the sides and back above the body of the grill.
- Keep all gas hoses away from the hot surfaces of the grill, including all external surfaces of the unit.
- Keep all electrical supply cords away from the hot surfaces of the grill, including all external surfaces of the unit.
- Ensure proper installation and servicing by following all instructions in this Use and Care Guide and any other instructions or markings provided with this product. Have your grill installed by a qualified technician. Have the installer show you where the gas supply shut-off valve is located and instruct you in its operation so that you can shut-off the gas to the grill.
- If you smell gas, there is likely a problem with the installation. If the connections are not perfectly sealed, you can have a small leak resulting in the faint smell of gas — even if the grill appears to be working properly. Close the gas supply shut-off valve and call a qualified technician to locate and resolve the leak.

SPIDER ALERT: Spiders and other insects are prone to nesting inside burners in outdoor cooking equipment. This can create a very dangerous condition where the gas flow is redirected and can create a fire behind the control panel or in the lower cabinet. This will damage the grill and make it unusable. Frequent inspections and care are recommended. See the care section beginning on page 32.

California Proposition 65 Warning:

The burning of gas cooking fuel generates some by-products that are on the list of substances which are known by the State of California to cause cancer or reproductive harm. California law requires businesses to warn customers of potential exposure to such substances. To minimize exposure to these substances, always operate the grill according to this Use and Care Guide and ensure you provide good ventilation when cooking.

Important LP Tank Safety Information

To avoid risk of fire or explosion, take the following safety precautions:

- Never replace the liquid propane regulator or hose with a different type than the model supplied.
- Never connect the grill to anything other than the fuel source indicated on the serial plate. Factory conversion kits are available for switching fuel sources. Contact Kalamazoo Outdoor Gourmet or an authorized dealer for details. Conversion kit installation must be done by a qualified technician.
- The LP-gas cylinder must include a collar to protect the cylinder valve from damage.
- An LP cylinder should never be overfilled beyond the cylinder filling capacity. Overfilling may create a dangerous condition. Overfilled tanks can build up excess pressure. The standard safety device on tanks is the safety relief valve. This valve vents propane gas vapors to relieve excess pressure. These vapors are combustible and can be ignited.
- Always ensure proper ventilation of the cylinder. See next page for proper ventilation required in an enclosure to safely dissipate gas vapors if there is a leak in your enclosure. The cylinder supply system must be arranged for vapor withdrawal. Cylinder must always be oriented in an upright position (Fig 1).
- The LP-gas supply cylinder to be used must be constructed and marked in accordance with the specifications for LP-gas cylinders, U.S. Department of Transportation (DOT) or the standard for *Cylinders, Spheres and Tubes for the Transportation of Dangerous Goods, CAN/CSA-B339*.
- When the grill is not in use, the gas must be disconnected at the supply cylinder.
- The grill may be stored indoors, but only if the cylinder is disconnected and removed from the grill. An LP cylinder **MUST NEVER BE STORED INDOORS**.
- Cylinders must be stored outdoors out of the reach of children and must not be stored in a building, garage or any other enclosed area.

DANGER:

Do not route the gas supply hose or locate a propane cylinder in a way that may create a tripping hazard. Tripping over, or getting caught on, a gas supply hose may tip the grill over or damage the hose, creating serious risk of injury and fire.

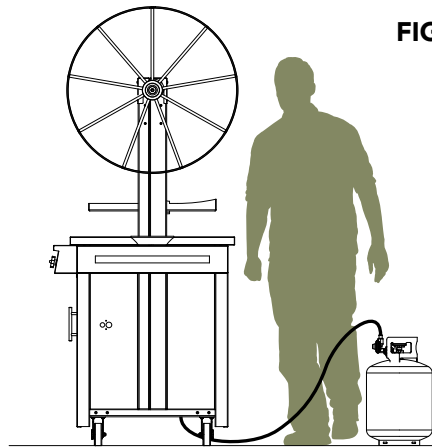

FIGURE 1

DANGER:

- A. Do not store a spare LP-gas cylinder under or near this appliance;
- B. Never fill the cylinder beyond 80 percent full; and
- C. If instructions A and B are not followed exactly, a fire causing death or serious injury may occur.

- The pressure regulator and hose assembly supplied with the grill must be used. Replacement pressure regulators and hose assemblies must be the type specified by Kalamazoo Outdoor Gourmet. For replacement parts, contact Kalamazoo Outdoor Gourmet customer service at 1.800.868.1699.

Connecting and disconnecting the LP tank:

- To connect the LP regulator hose assembly to the LP tank, first make sure the main valve on the tank is completely closed. Make sure also that all control valves on the front of the grill are OFF.
Thread the regulator inlet over the tank valve. Use care to ensure proper alignment of the threaded coupler and avoid cross-threading or damaging the coupler. Turn the coupler clockwise until tightened up, but do not over-tighten.
- To disconnect the LP regulator hose assembly from the LP tank, first make sure the main valve on the tank is completely closed. Make sure also that all control valves on the front of the grill are OFF.
Turn the coupler counter-clockwise until disconnected.

Required ventilation for built-in LP-gas cylinder structures:

An enclosure for an LP-gas cylinder shall be ventilated by openings at both the upper and lower levels of the enclosure. The effectiveness of the opening(s) for purposes of ventilation shall be determined with the LP-gas supply cylinder in place. This shall be accompanied by one of the following:

- A. One side of the enclosure shall be completely open; or
- B. For an enclosure having four sides, a top and a bottom:
 1. At least two ventilation openings shall be provided in the side walls of the enclosure, located within 5 in (217 mm) of the top of the enclosure, equally sized, spaced at a minimum of 90 degrees (1.57 rad), and unobstructed. The opening(s) shall have a total free area of not less than 1 in²/lb (14.2 cm²/kg) of stored fuel capacity.
 2. Ventilation opening(s) shall be provided at floor level of the enclosure and shall have a total free area of not less than 1/2 in²/lb (7.1 cm²/kg) of stored fuel capacity. If ventilation openings at floor level are in a side wall, there shall be at least two openings. The bottom of the openings shall be 1 in (25.4 mm) or less from the floor level and the upper edge no more than 5 in (127 mm) above the floor level. The openings shall be equally sized, spaced at a minimum of 90 degrees and unobstructed.
 3. Every opening shall be a minimum of a 1/8 in (3.2 mm) diameter.
 4. Ventilation openings in side walls shall not communicate directly with other enclosures of the outdoor cooking gas appliance.
 5. A door on the enclosure to gain access to the cylinder is acceptable, provided it is nonlocking and can be opened without the use of tools.
- C. Some means of retention (chain, bracketry, cut-out) must be used to hold cylinder in place inside enclosure
- D. There shall be a minimum clearance of 2 in (50.8 mm) between the floor of the LP-gas cylinder enclosure and the ground.

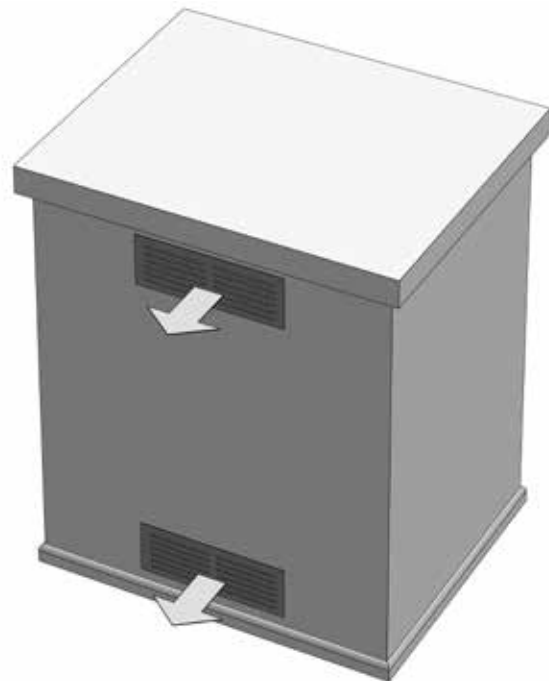

Liquid Propane Gas Requirements (20-Pound Cylinder)

Verify the type of gas your grill has been configured for by the factory by checking the serial tag inside the door of the grill cabinet. Grills configured for liquid propane (LP) gas are orificed differently than grills configured for natural gas (NG). Grills configured for use a standard 20-pound LP cylinders are shipped with a dual-stage LP regulator hose assembly attached.

Connection: LP regulator hose assembly (included) connects to the grill via 0.5" NPT male with a 0.375" flare adapter (included).

Operating Pressure: 11.0" W.C. (cooktop burners) and 8.0" W.C. (all other burners via additional regulator installed inside grill).

Cylinder Requirements: For use with 20 -pound (9kg) Type 1 LP cylinder with a UL listed Type 1, QCC-1 valve. Cylinder must have an overfilling prevention device. Cylinder must be provided with a cylinder connection device compatible with the connection for outdoor cooking appliances. Never use a dented or rusty LP tank. Never use a cylinder with a damaged valve. Always check for leaks after connecting an LP tank.

Other LP cylinders may be acceptable for use with grill provided they are compatible with the retention means depicted in Figure 2.

IMPORTANT: Always close the main valve on the tank before disconnecting or transporting the tank.

IMPORTANT: After connecting a fresh LP tank, you may need to purge air from the system. Before lighting, open the main valve on the tank. Turn the control valves on the grill to the HIGH position for about 15 seconds to purge air from the system. Turn the control valves on the grill OFF and wait 5 minutes for any gas to clear. Finally, continue with the normal lighting procedure.

The installation must conform with local codes. In the absence of local codes, the installation must conform with the *National Fuel Gas Code, ANSI Z223.1/NFPA 54*; *Storage and Handling of Liquefied Petroleum Gases, ANSI/NFPA 58*; *Natural Gas and Propane Installation Code, CSA B149.1*; or *Propane Storage and Handling, CSA B149.2*.

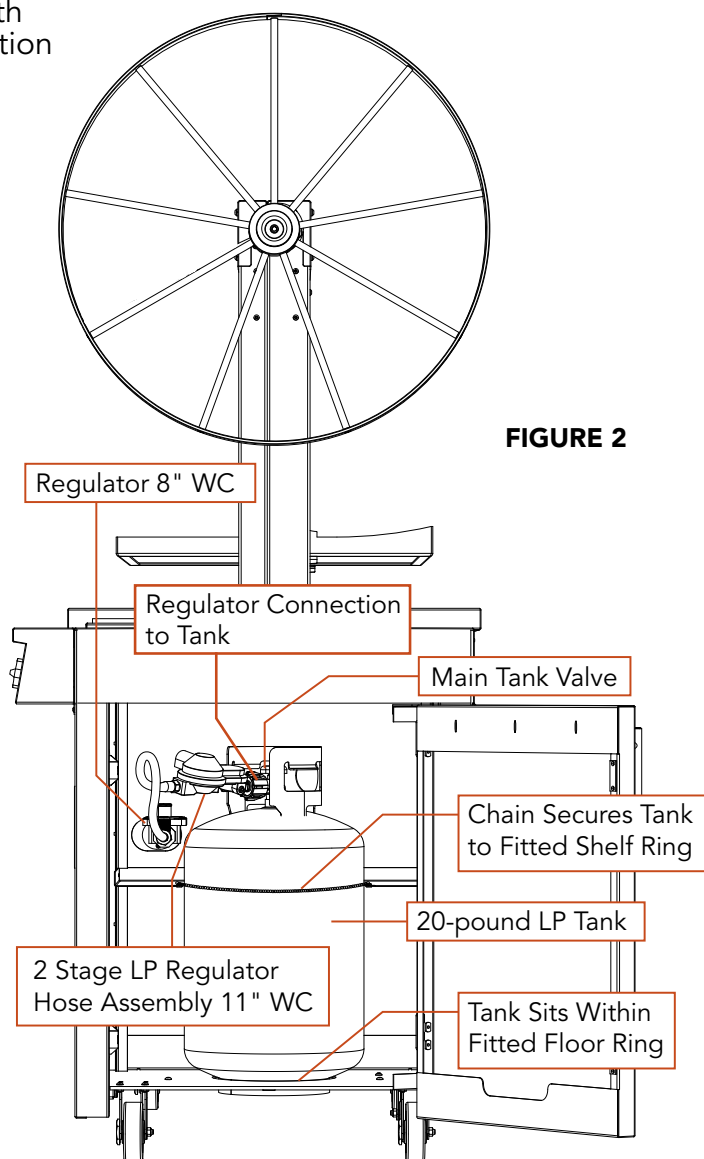

Natural Gas Requirements

Verify the type of gas your grill has been configured for by the factory by checking the serial tag inside the door of the grill cabinet. Grills configured for natural gas (NG) are orificed differently than grills configured for liquid propane (LP) gas. Grills configured for use with natural gas are shipped with a gray hose with a quick-connect fitting.

Connection: Quick-connect hose assembly (included) connects to the grill via 0.5" NPT male with a 0.375" flare adapter (included).

Input Pressure: 7.0" W.C.

Input Connection: 0.5" male NPT fitting

Operating Pressure: 7.0" W.C. (cooktop burners) and 3.5" W.C. (all other burners via additional regulator installed inside grill).

IMPORTANT: Always close gas supply shut-off valve before disconnecting the grill gas supply hose.

IMPORTANT: An installer-supplied safety shut-off valve **MUST** be installed on the natural gas supply line for the grill. The valve should be easily accessed and located between 3 and 20 feet away from the grill.

All gas connections should be made by a qualified technician. The installation and all installer-supplied parts must conform to local codes. In the absence of local codes, the installation and all parts should conform to the *National Fuel Gas Code, ANSI Z223.1/ NFPA 54* or *Natural Gas and Propane Installation Code, CSA B149.1*.

All pipe sealants must be an approved type.

IMPORTANT: Diameter and length of the gas supply pipe may limit the pressure and BTU delivery of gas to the grill. The installer must ensure proper delivery to the grill or it will not operate properly.

The appliance and its individual shut-off valve must be disconnected from the gas supply piping system during any pressure testing of that system at pressures in excess of 1/2 psi (3.5 kPa).

During any pressure testing of the gas supply piping system at test pressures equal to or less than 1/2 psi (3.5 kPa), the appliance must be isolated from the system by closing its individual manual shut-off valve.

FIGURE 3

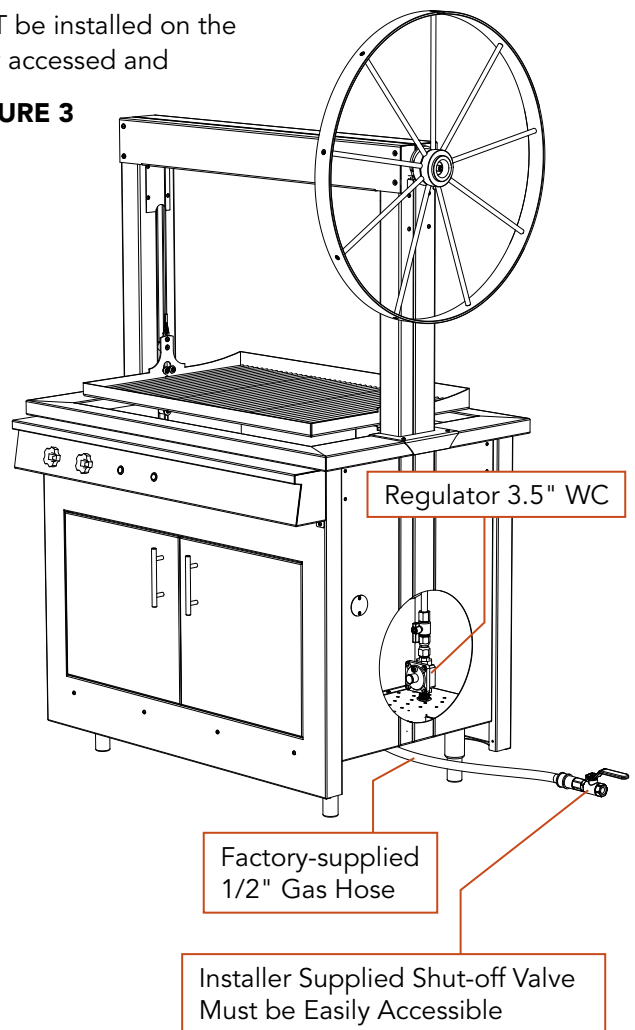

Bulk Supply Liquid Propane Gas Requirements

Verify the type of gas your grill has been configured for by the factory by checking the serial tag inside the door of the grill cabinet. Grills configured for liquid propane (LP) gas are orificed differently than grills configured for natural gas (NG). Grills configured for use with a bulk LP supply are shipped with a gray hose with a quick-connect fitting.

Connection: Quick-connect hose assembly (included) connects to the grill via 0.5" NPT male with a 0.375" flare adapter (included).

Input Pressure: 11.0" W.C.

Input Connection: 0.5" male NPT fitting

Operating Pressure: 11.0" W.C. (cooktop burners) and 8.0" W.C. (all other burners via additional regulator installed inside grill).

IMPORTANT: Always close gas supply shut-off valve before disconnecting the grill gas supply hose.

IMPORTANT: Diameter and length of the gas supply pipe may limit the pressure and BTU delivery of gas to the grill. The installer must ensure proper delivery to the grill or it will not operate properly.

IMPORTANT: An installer-supplied safety shut-off valve **MUST** be installed on the gas supply line for the grill. The valve should be easily accessed and located between 3 and 20 feet away from the grill.

All gas connections should be made by a qualified technician. The installation and all installer-supplied parts must conform to local codes. In the absence of local codes, the installation and all parts should conform to the *National Fuel Gas Code, ANSI Z223.1/NFPA 54; Storage and Handling of Liquefied Petroleum Gases, ANSI/NFPA 58; Natural Gas and Propane Installation Code, CSA B149.1; or Propane Storage and Handling, CSA B149.2.*

All pipe sealants must be an approved type.

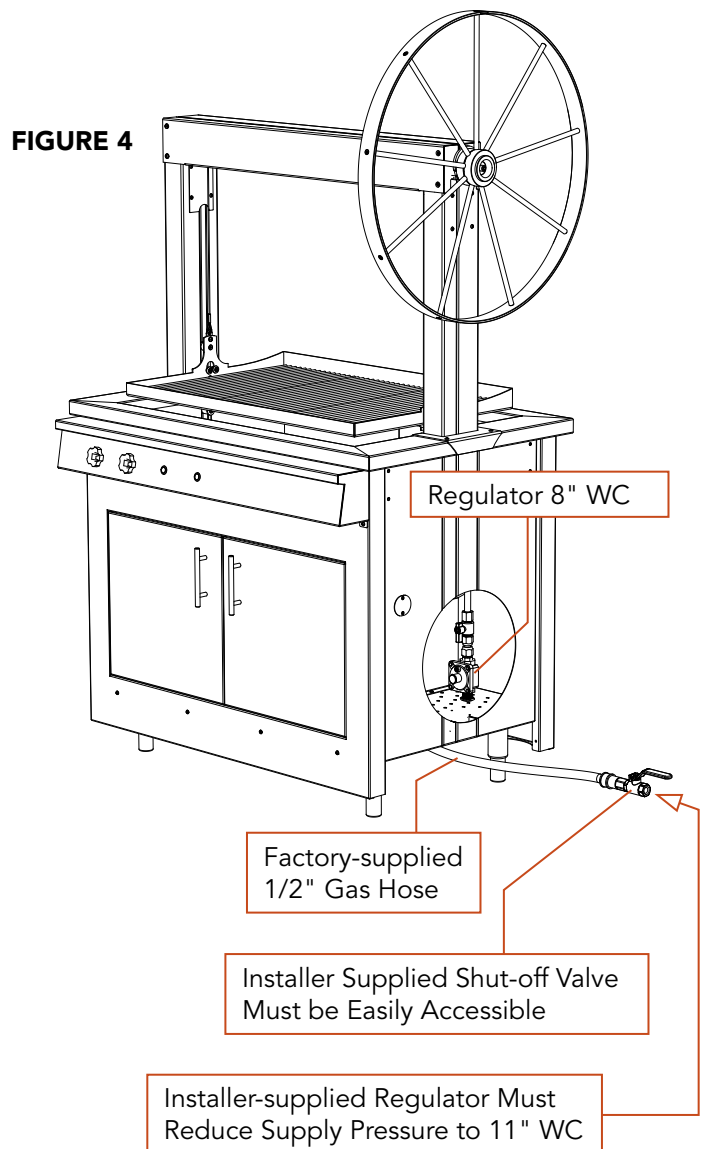

Leak Testing

Although gas connections on the grill are leak tested at the factory prior to shipment, a complete test must be performed after installation due to possible mishandling during shipping or installation.

Periodic checks are also recommended. Immediately check for leaks if you smell gas.

Never use an open flame to look for leaks.

Before Testing: Extinguish all open flames. Do not smoke.

You will need a spray bottle, a brush or a rag. For LP units using a 30-pound cylinder, a full cylinder should be used.

IMPORTANT: Homeowners should only check for leaks on the gas connections that are external to the grill. If the valves or other internal connections need to be checked, please call a qualified technician or Kalamazoo Outdoor Gourmet customer service at 1.800.868.1699.

To Conduct the Test:

Make a soap solution of one part liquid dish soap and one part water.

Make sure all grill control valves are in the OFF position. Turn the gas supply ON. Use a spray bottle, brush or rag to apply the mild soap solution to all connections from the supply line or LP cylinder to the connection on the grill. Check all connections. Soap bubbles will appear at any connections with a leak. Turn OFF the gas supply and tighten any leaky connections. Recheck, applying more mild soap solution.

***IMPORTANT:** Do not use the grill until all connections have been checked and do not leak.*

Electrical Connection

The grill requires AC power for ignition, the control panel lighting, and rotisserie motor functionality. It must be connected with an outdoor-rated, grounded electric extension cord.

The grill, when installed, must be electrically grounded in accordance with local codes or, in the absence of local codes, with the National Electrical Code, ANSI/NFPA 70, or the Canadian Electrical Code, CSA C22.1.

See additional electrical precautions on page 37.

Grill Location

The Kalamazoo Gaucho Grill is designed for easy placement on an outdoor patio or deck. It is recommended that the grill be placed on a non-combustible surface.

Choosing a Location: Important considerations for grill placement include exposure to wind, proximity to foot traffic and areas where people congregate and access to the gas supply.

Do not place the grill in a location where it is likely to be exposed to strong wind.

Do not place the grill where it is likely to be bumped into or inadvertently touched by passers by. It is recommended that the countertop or other surface extend 9 inches beyond the sides and back of the grill as a safety clearance to protect people from injury.

Do not place the grill on a surface that is unable to safely support the weight of the grill or may cause it to be unstable.

Never place the grill where the gas hose creates a safety hazard (see Figure 1). Tripping over an exposed gas hose may create a gas leak or create other serious safety hazards.

Never locate the grill in a building, breezeway, shed or other such enclosed areas.

The grill is not intended to be installed in or on a boat or recreational vehicle.

REQUIRED CLEARANCES

IMPORTANT: Do not build the grill into a combustible enclosure. Maintain at least 36 inches of clearance between the sides and back of the grill and any combustible surface. NEVER place the grill underneath an overhead combustible structure or surface.

For ease of use and safe operation, it is recommended the grill be placed on a level surface.

Grill Dimensions



K750GB Gaucho Built-in Grill

K750GB

- Wood-fired grilling with grill grate and motorized rotisserie spit that raise and lower above the fire
- 726 square inches of grilling area
- Two powerful gas burners to start the wood fire
- Deep hopper cleaning
- Stainless steel leveling legs
- 3 amps

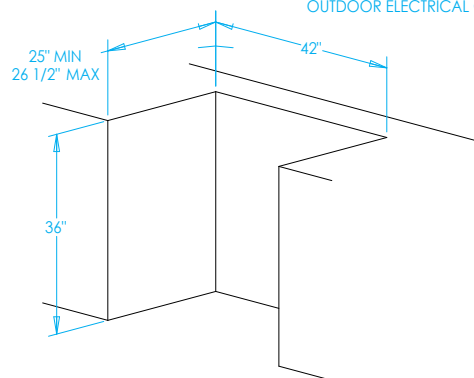
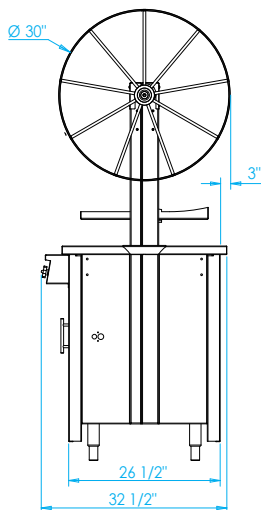
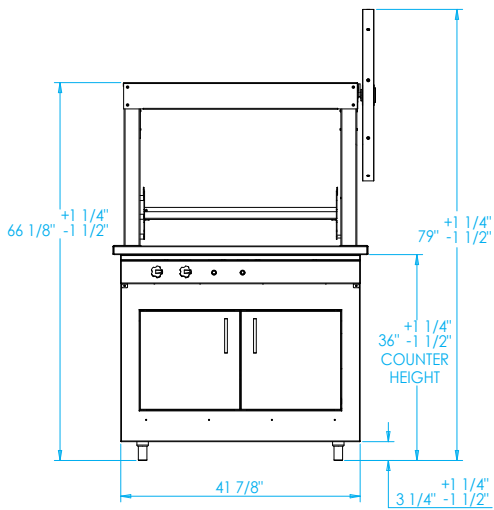
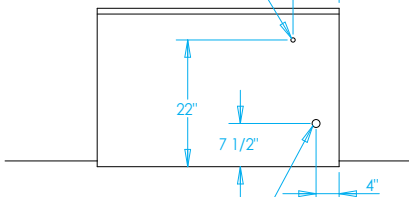
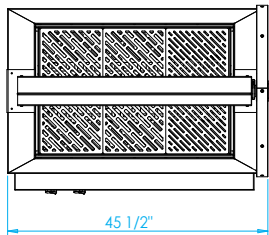
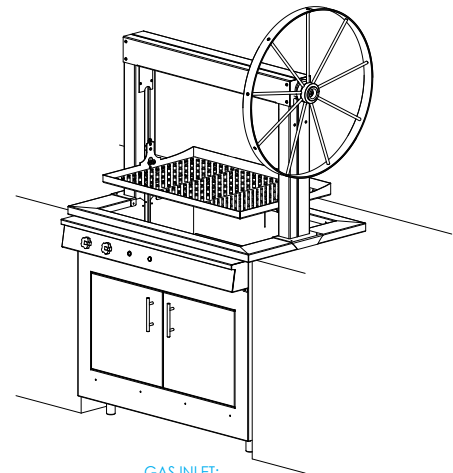
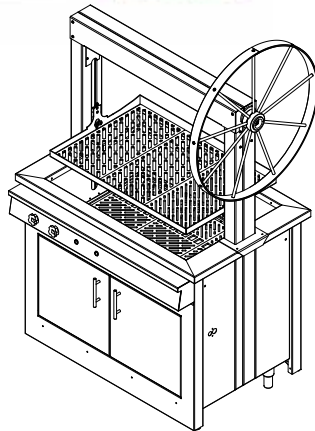



K750GS Gaucha Freestanding Grill

K750GS

- Wood-fired grilling with grill grate and motorized rotisserie spit that raise and lower above the fire
- 726 square inches of grilling area
- Two powerful gas burners to start the wood fire
- Deep hopper cleaning
- Heavy-duty castors
- Double cooktop with two 16,000 BTU burners
- Propane cylinder storage in right-end cabinet
- 3 amps

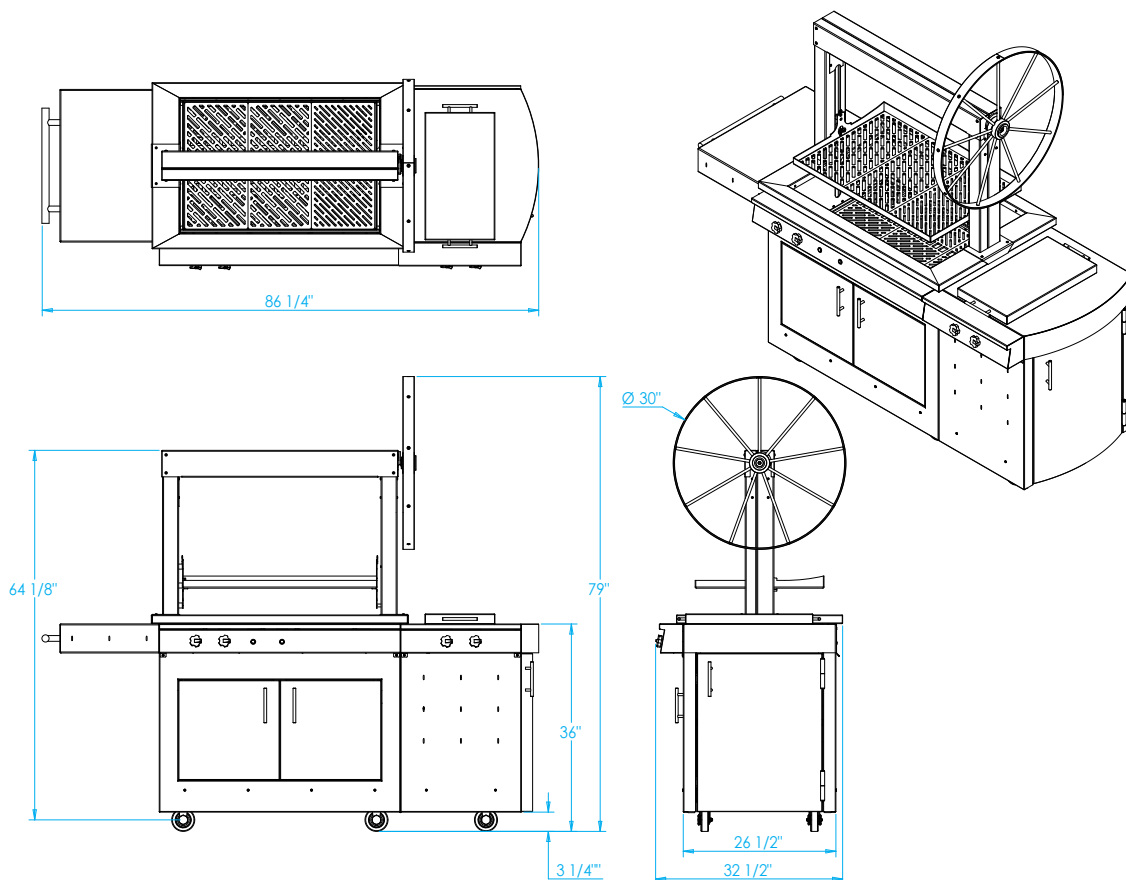



K750GT Gaucha Freestanding Grill

K750GT

- Wood-fired grilling with grill grate and motorized rotisserie spit that raise and lower above the fire
- 726 square inches of grilling area
- Two powerful gas burners to start the wood fire
- Deep hopper cleaning
- Heavy-duty castors
- Two side shelves
- 3 amps

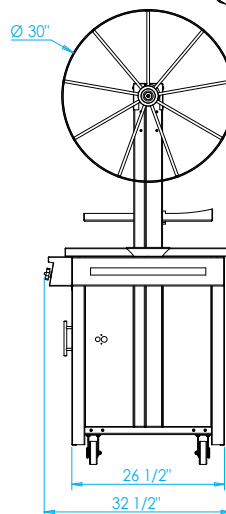
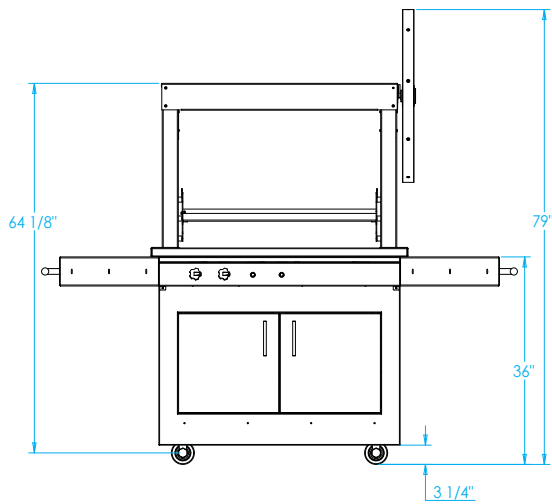
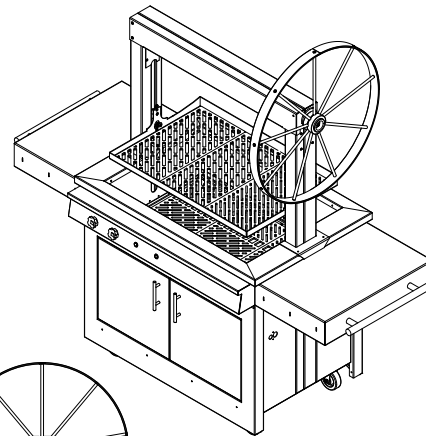
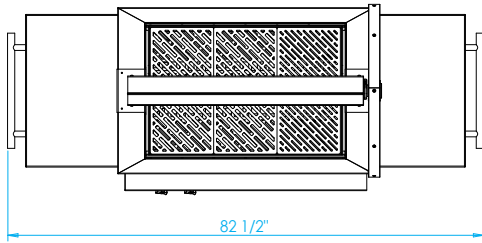

Initial Assembly

Your Kalamazoo Gacho Grill requires only minor assembly, but many parts are individually wrapped to prevent damage. The only tool required is an hex key (provided) to mount the wheel. In the case of the K750GS model, you may also need to install the left side shelf.

- A.** Mount the wheel. First, set rectangular keystone into slot at the end of the spindle, see inset. (The spindle protrudes from right end of the upper cross member) Visually align the spindle key with the square keyway inside the hub of the wheel. Place the wheel hub on the spindle, and rotate slowly to locate the keyway. Slide the wheel all the way onto the spindle. Insert the hub bolt through the wheel and into the spindle, tightening with the supplied large hex key. Use supplied set screw and small hex key to tighten the keystone in place.
- B.** Insert the three laser-cut stainless steel fire grates into the firebox of the grill so they rest on the ledges inside and are positioned directly above the burners. The square holes should be positioned slightly behind the burner locations.
- C.** Place the grill grates into the grill rack, or...
- D.** Remove one, two or three grill grates in order to make room for the rotisserie spit. The rotisserie spit can be used in conjunction with one or two grill grates if the length of the food on the spit allows room. Insert the rotisserie spit by sliding the pointed end through the hole in the left side of the grill rack first, and then sliding other end into the hex socket in the right side of the grill rack (see Figure 10).
- E.** If not already on the unit, mount the CONTROL KNOBS on the valve posts.
- F.** Connect the 12-inch grounded power cord (supplied) to the control box in the right side of the lower cabinet.
- G.** Install the firebox ash chute gate by sliding it over the guides at the bottom of the firebox inside the lower cabinet.
WARNING: Always be sure the chute is closed when the grill is in operation. Never touch the chute gate while the grill is hot. Wait 24 hours after a fire before opening the chute.
- H.** Place the ash bin in the cabinet, seated between the posts mounted in the floor.
WARNING: Never touch or empty the ash bin when the grill is hot. Always wait at least 24 hours before emptying the ash bin.

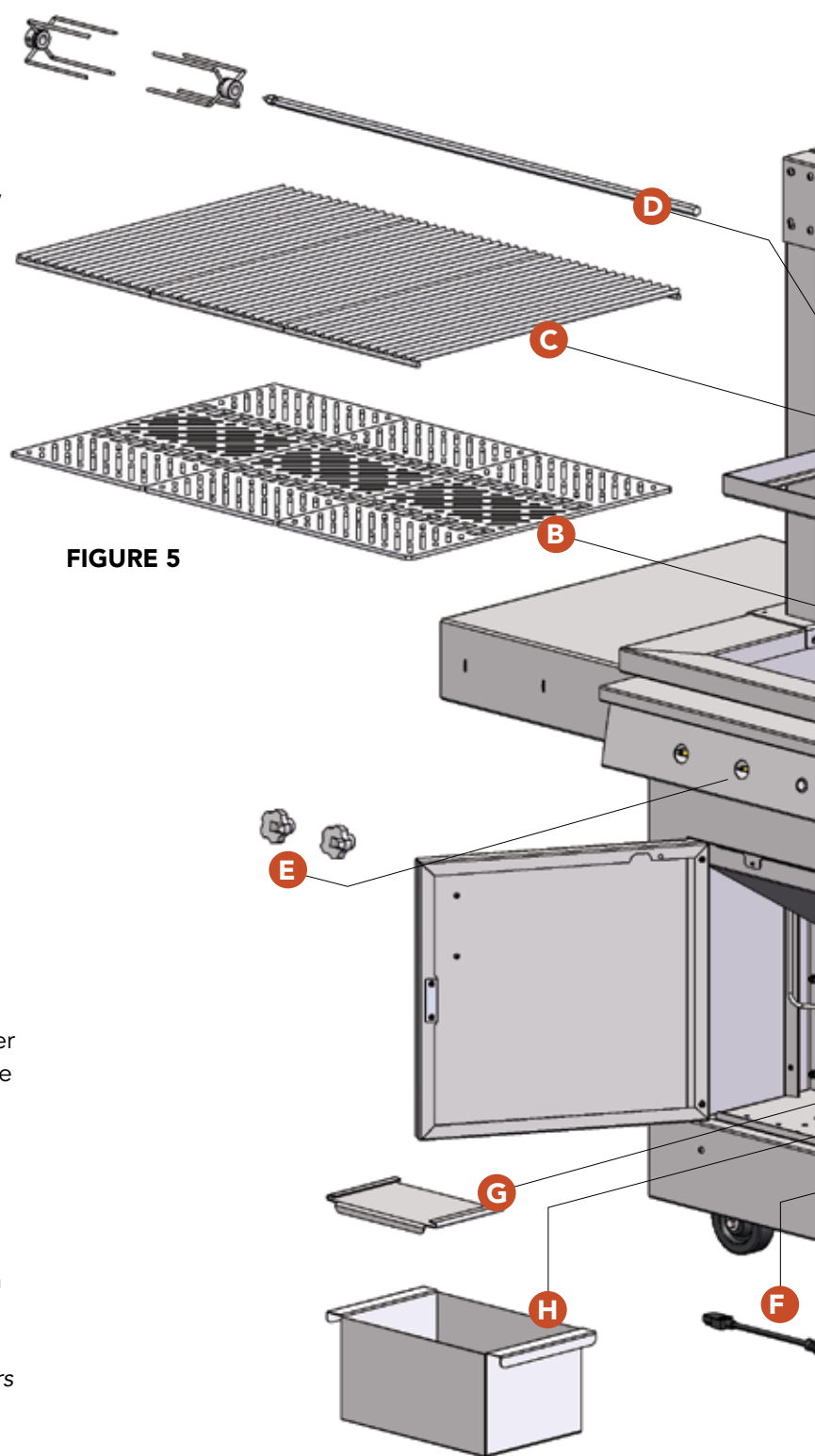
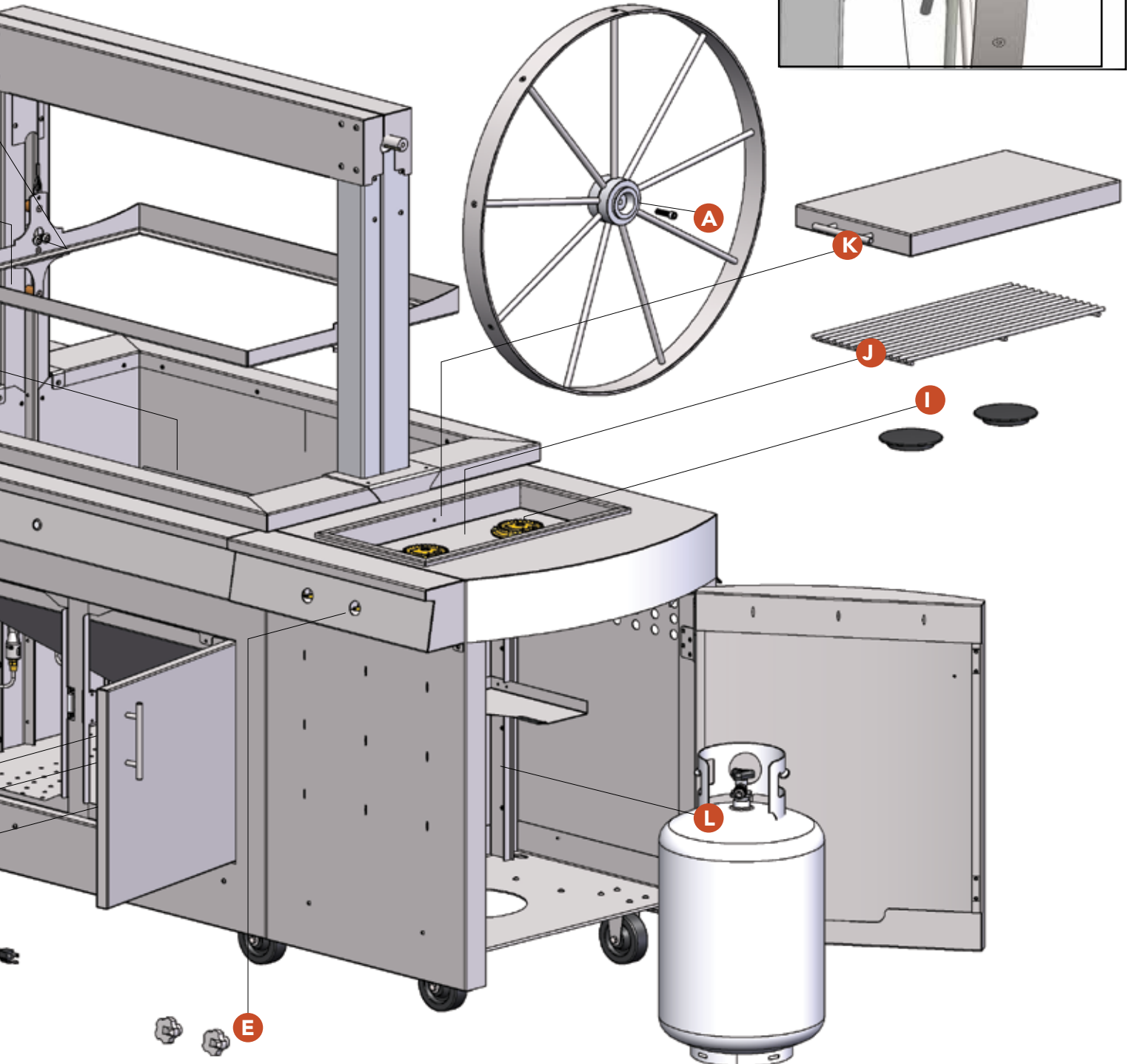

FIGURE 5

K750GS Model Only:

- I.** Place the cooktop burner diffusion caps on the cooktop burners.
- J.** Place the cooktop burner grid on the cooktop burner tray.
- K.** Place the cooktop cover over the cooktop.
- L.** Place an LP cylinder (not included) in the side cabinet and secure with chain.



Get to Know Your Grill

- A. Wheel:** Raise and lower the grill rack (see Figure 7:C) by rotating the wheel (A). The rack can be raised by rotating the wheel counter-clockwise (pull down on the front of the wheel rim). **Always wear protective gloves when operating the wheel. It can become hot when the grill is in use.**

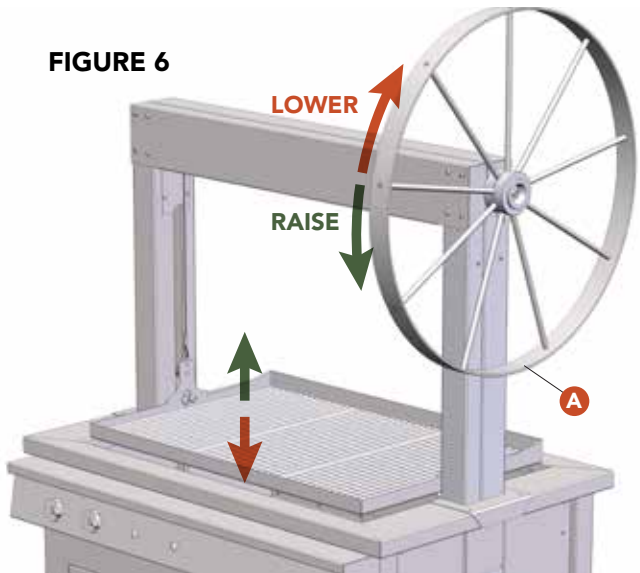

IMPORTANT: Always use the wheel to lower the grill rack. Do not let the wheel spin freely as the rack lowers.

- B. Grill Rack:** Raise and lower the grill rack to control the intensity of the heat above the fire.
- C. Upper Grill Rack Stop:** Stops are located on both uprights at the maximum height position for the grill rack. Do not force the grill rack into the stops.

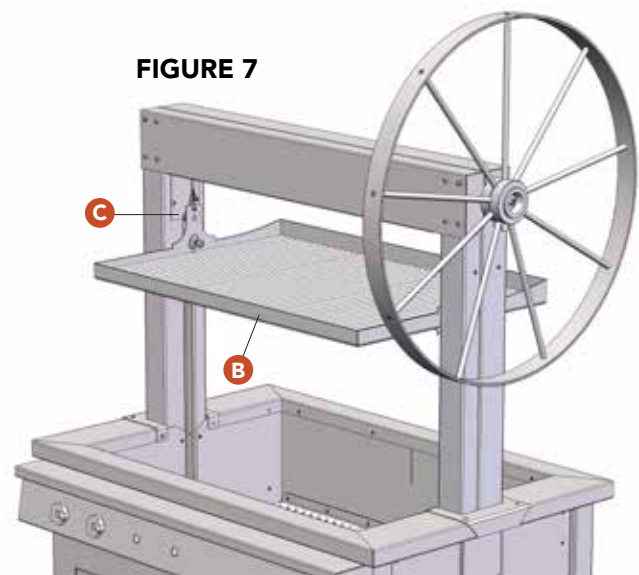

- D. Front Starter Burner:** The front and rear starter burners are used to start a wood and/or charcoal fire. These burners do not provide cooking heat. They are used only for starting your cooking fire. Turn the burners off after the wood or charcoal fire is strong and self-sustaining. Each burner is protected below heavy gauge sheet metal shields.
- E. Front Burner Control Valve:** Controls the front burner (D) and activates the front burner igniter (F). SEE LIGHTING INSTRUCTIONS.
- F. Front Burner Igniter:** Lights the front starter burner (D) and is controlled by the front control knob (E). Hot surface igniter is activated by pressing in the front burner control knob. The igniter is protected by a heavy gauge sheet metal shield. Use care when cleaning the grill to avoid damaging the igniter.
- G. Rear Starter Burner:** Located across the rear of the grill and controlled by the rear burner control valve (H).
- H. Rear Burner Control Valve:** Controls the rear starter burner (G) and activates the rear igniter (I).
- I. Rear Burner Igniter:** Lights the rear starter burner (G) and controlled by the rear control knob (H).

FIGURE 8

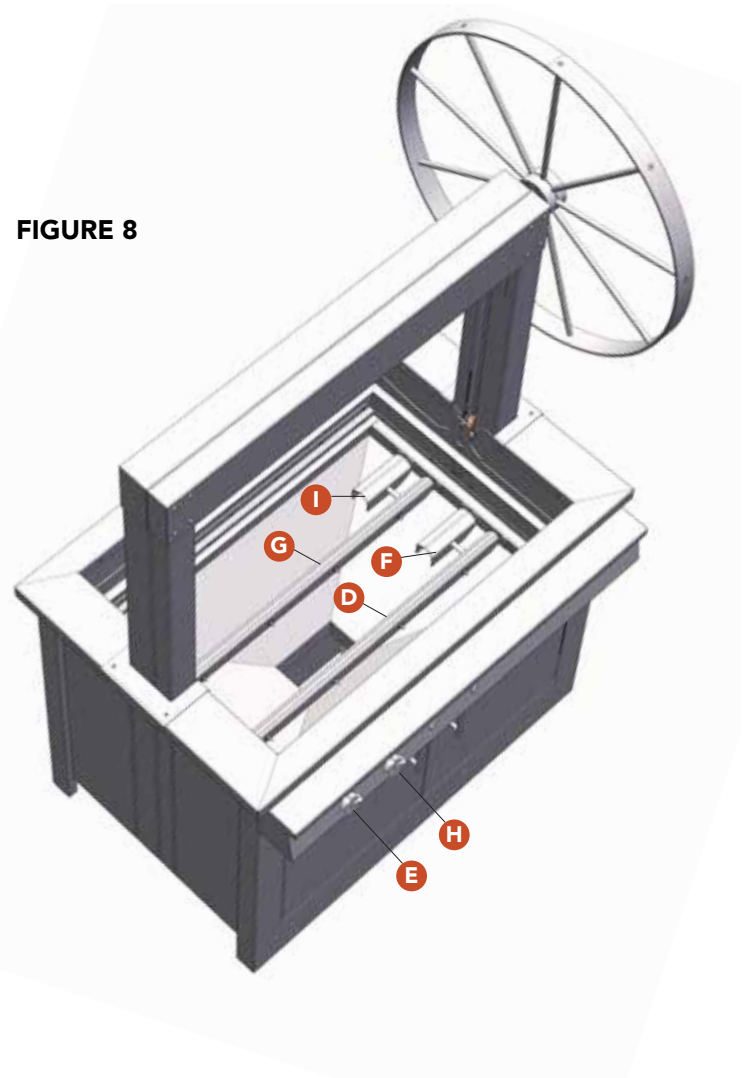
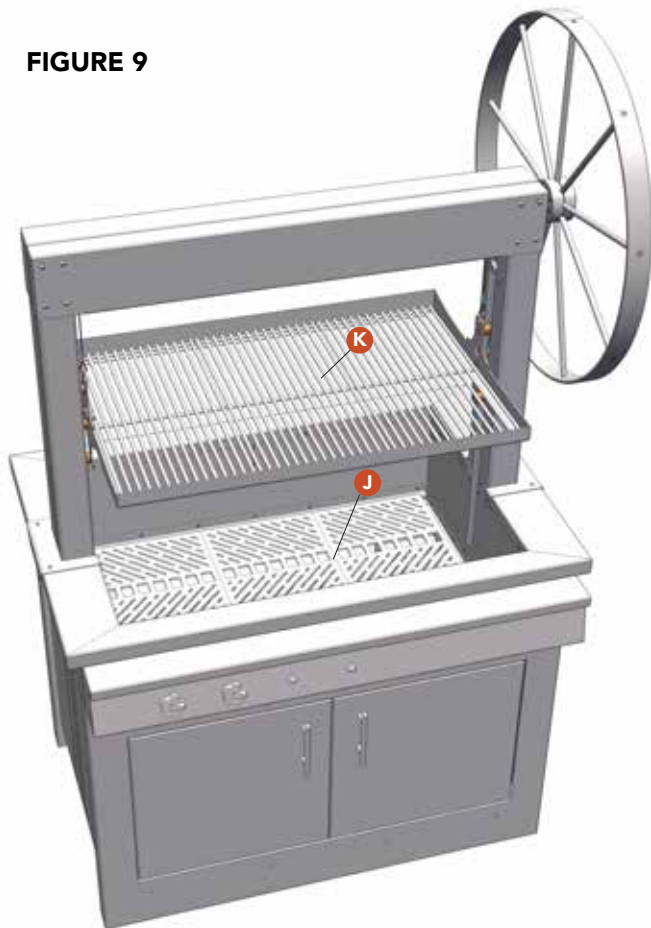

FIGURE 9



- J. Fire Grates:** The fire grates are laser-cut from thick stainless steel. The special pattern accelerates fire starting from the starter burners below and effectively holds the heat and embers from a mature fire.
- K. Grill Grates:** Standard grill grates are made from heavy stainless steel rods. Optional grill grates enhance performance. Choose from laser-cut grill grates in patterns optimized for meat, fish or vegetables. Also available are Argentinian-style slanted "V" grates with drippings pans. The grill rack (B) holds up to three grill grates.

- L. Rotisserie Spit:** Remove one, two or three grill grates (before the grill is hot) in order to make room for the rotisserie spit. The rotisserie spit can be used in conjunction with one or two grill grates if the length of the food on the spit allows room. Insert the rotisserie spit by sliding the pointed end through the hole in the left side of the grill rack first, and then sliding other end into the hex socket in the right side of the grill rack.
- M. Electric Rotisserie Motor:** The rotisserie spit is driven by an electric motor and chain drive system. The grill must be connected to AC power for the motor to work. Activate the motor by pressing the button (M) on the control panel. The rotisserie will operate with the grill rack at any height, and the rack can be moved with the motor in operation. You may notice the rotisserie spit rotation changing speed or direction when raising or lowering the grill rack. This is a normal function of the chain driven system.

FIGURE 10

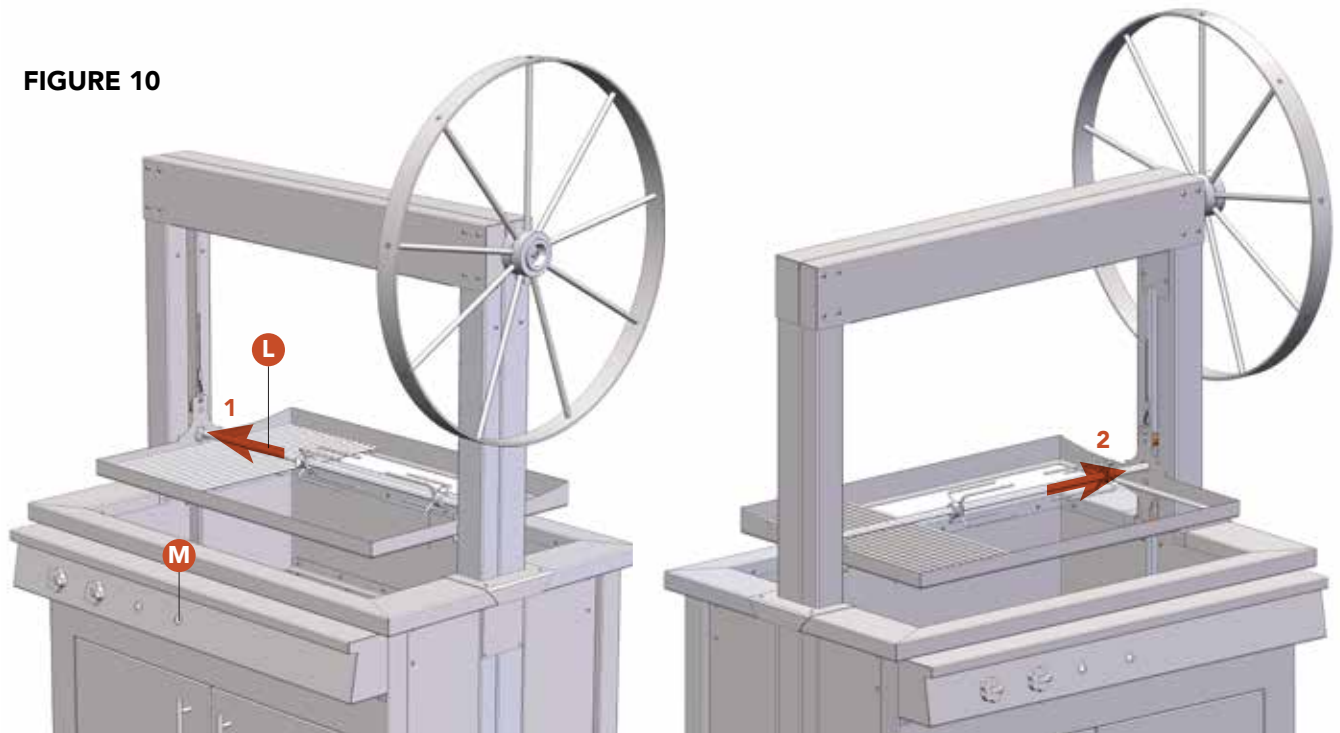
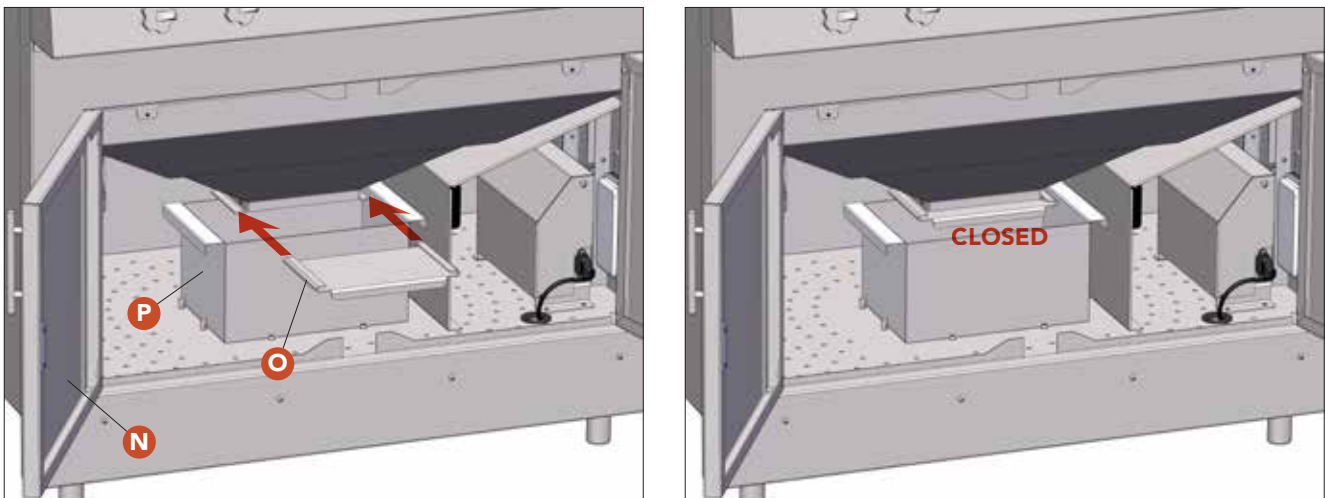

FIGURE 11



- N. Access Doors:** The cabinet below the grill is not for storage. This space contains the cleanout pan and the electrical system for the grill. *Never store combustible materials inside this cabinet or any items that may be damaged by heat.* The rotisserie spit and forks may be stored inside the cabinet. *Never attempt to store a LP cylinder underneath the grill.*
- O. Firebox Closure:** The bottom chute of the firebox must be closed off during operation to prevent excessive heat outside the insulated firebox. Close the chute by sliding the chute gate back fully over the guides. After the embers and ash are completely cooled (24 hours after a fire), remove the chute gate to allow ash to drop into the ash bin. Close the chute gate and empty the ash bin.
- P. Ash Bin:** The ash bin sits below the firebox chute and is located in position by a set of pins in the floor of the grill. *Never touch the chute closure or the ash bin when the grill is hot.* Rain water can accumulate in the ash bin. It is recommended the ash bin be emptied of water before each grill use and before opening the chute closure.

CAUTION: Always keep the firebox chute (figure 11:O) closed when the grill is in operation.

CAUTION: Always wait 24 hours after a fire before opening the chute and emptying the ash bin. Always dispose of ash in a suitable container.

FIGURE 12

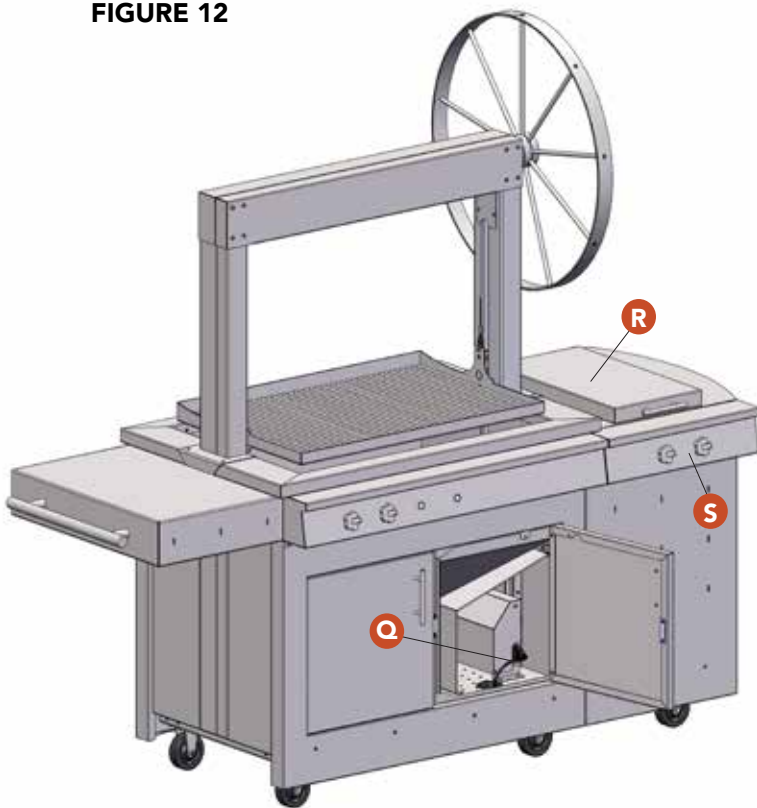

- Q. Electrical System Power Cord:** This cord connects the power for the ignition system as well as the power for the rotisserie motor and control panel lighting. Use a customer-supplied single-outlet outdoor-rated extension cord to connect this short cord provided by Kalamazoo Outdoor Gourmet to an outdoor-rated GFI outlet. The customer-supplied cord should be fed up through the hole in the floor pan of the grill that is protected by a rubber grommet.
- R. Cooktop Cover:** *Never operate the cooktop burners with this cover in place.* Stow the cover in the side door when using the cooktop burners (see Figure 15). Cover the burners when not in use.
- S. Cooktop Control Panel:** See the following section on grill controls.

- T. Cooktop Grate:** Supports pots and pans above the cooktop burners. Do not cover the entire grate with a griddle or otherwise block airflow above the burners.
- U. Cooktop Burners:** The cooktop burners are made from machined brass with enameled cast iron diffusion caps. The diffusion caps sit loosely on top of the machined brass pieces. The caps must be in place on top of the brass cooktop burners before the burners can be used.

FIGURE 13

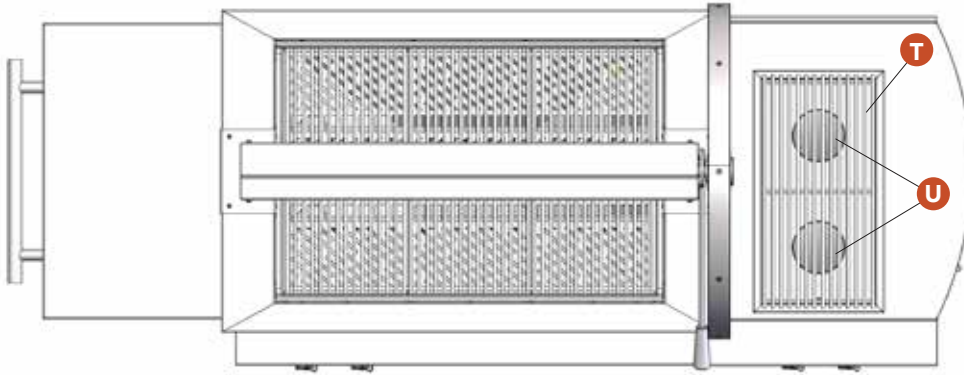

- V. Cooktop Ignition Battery Boxes:** The cooktop electronic ignition system uses battery power. The battery is contained inside this module, which can be accessed from inside the cooktop cabinet on the right side of the grill.

- W. Side Cabinet Door:** Access the LP cylinder by opening the side cabinet door. Stow the cooktop cover in the door when using the cooktop burners. Always position the top of the cover toward the door to avoid scratching the cover. Insert one handle up into the top opening of the door. Swing the bottom handle through the notch in the bottom of the door and lower the cover down to rest inside the door.

FIGURE 14

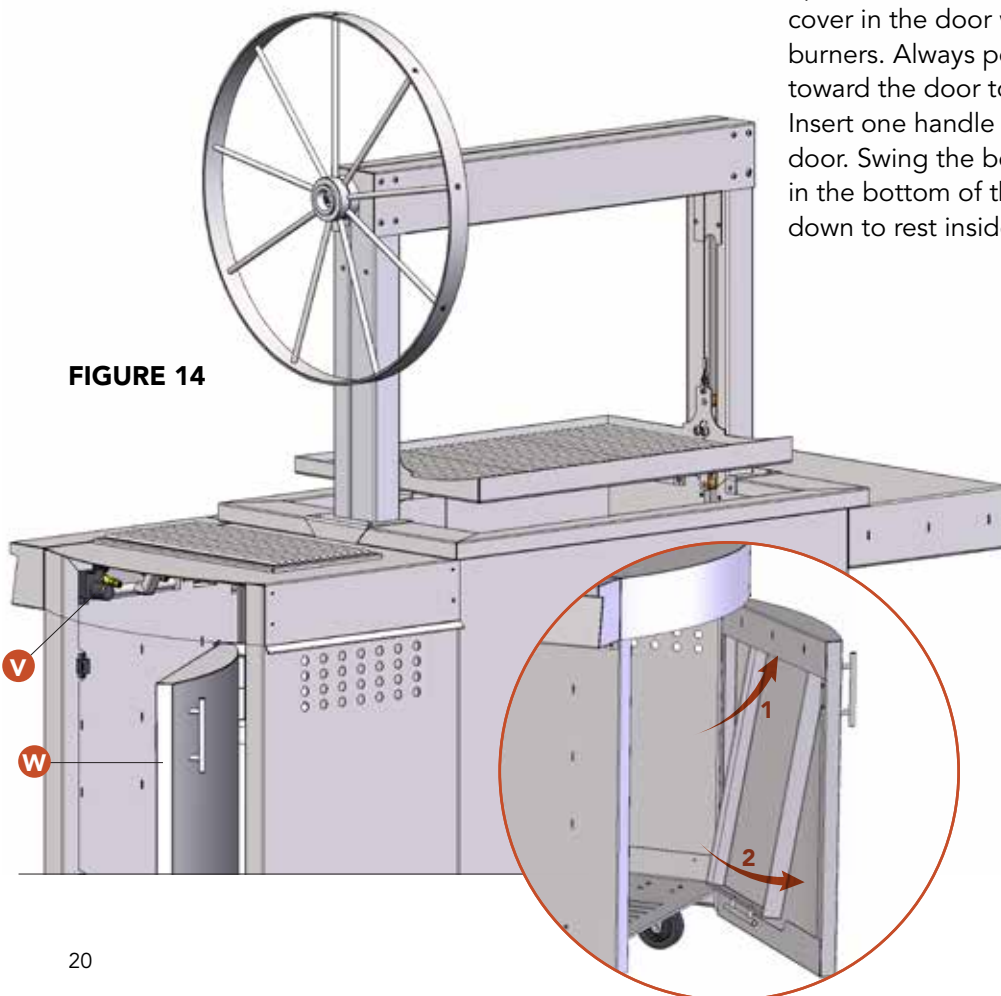

X. Firebox Cover: The firebox cover should be installed when the grill is not in use, after it has cooled. The left piece of the two-piece cover has a gutter along the edge. Install the left piece first, then install the right piece so that it sits inside the gutter on the left piece. The cover sides cannot be reversed. They will not fit in the firebox.

Never install the cover while the grill is in operation or still hot. Do not use the cover to attempt to snuff a fire. Do not operate the grill while the cover is in place.

The cover is designed to keep the firebox clear of debris and to protect components of the grill. The cover will not prevent rain water from entering the grill. Rain water will get inside the grill through a number of openings. In particular, the ash bin (Figure 11:P) will fill with rain water unless the grill is sheltered or the optional Sunbrella® grill cover is used.

FIGURE 15

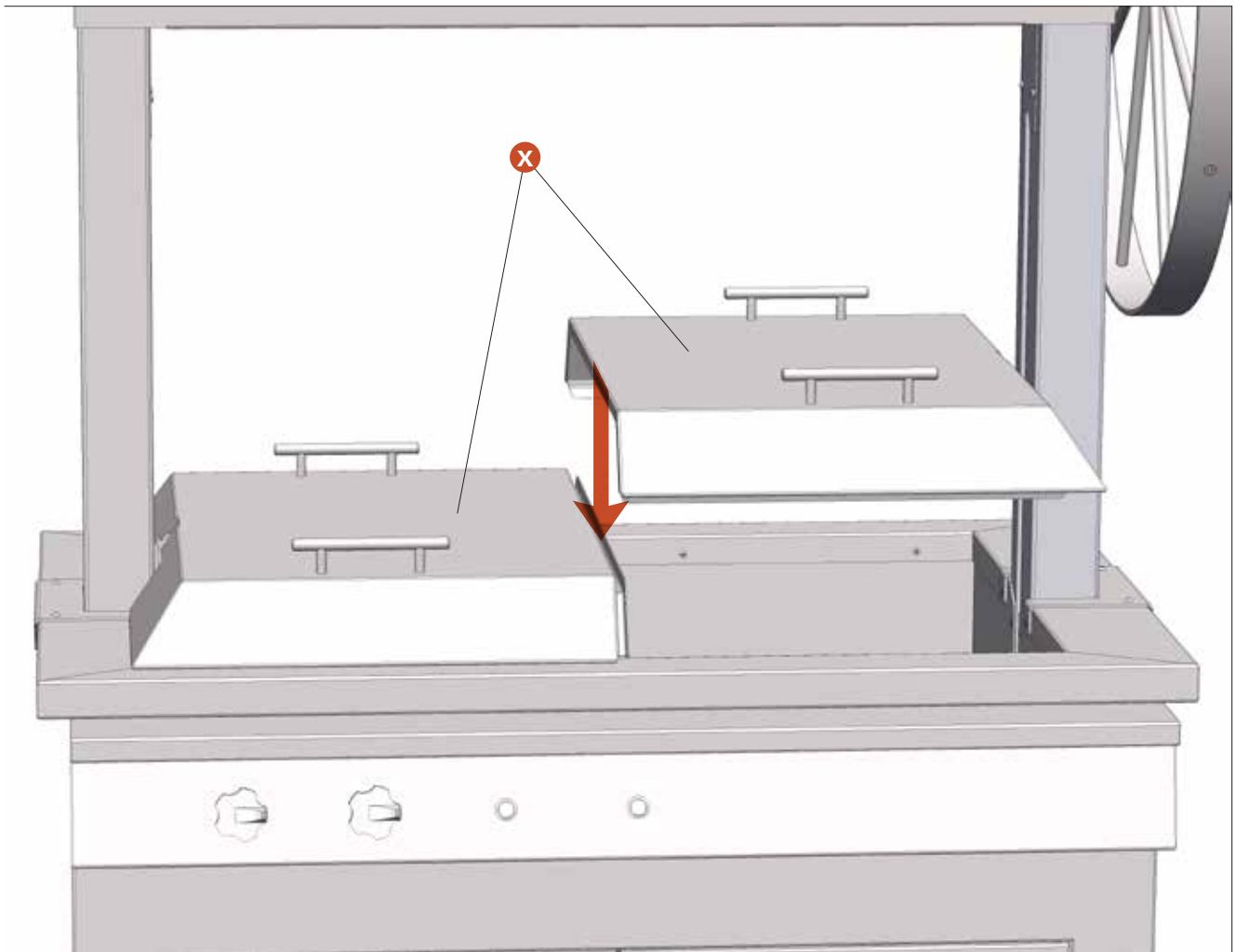

CAUTION: Never install the cover while the grill is hot or use the grill while the cover is in place.

Grill Controls

FIGURE 16

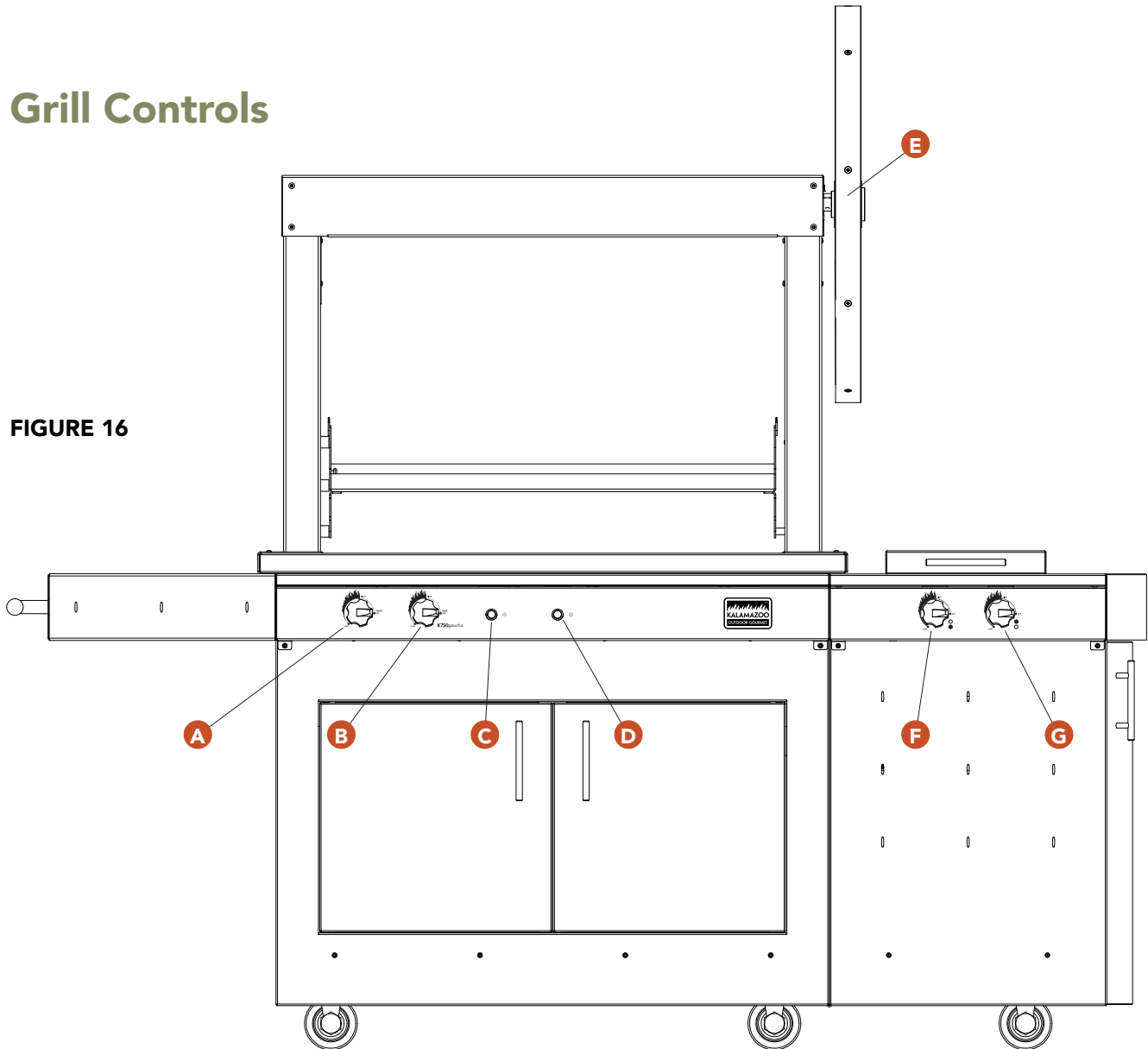

- A. Front Starter Burner Control:** Controls the flame on the front starter burner, which is used to ignite the wood cooking fire. The electronic ignition for the front starter burner is activated by pressing in the burner control knob. Requires grill to be plugged into an outdoor GFI outlet (120V).
- B. Rear Starter Burner Control:** Controls the flame on the rear starter burner which is used to ignite the wood cooking fire. The electronic ignition for the rear starter burner is activated by pressing in the burner control knob. Requires grill to be plugged into an outdoor GFI outlet (120V).
- C. Control Panel Lighting On/Off Switch:** Activates ambient LED lighting. Requires grill to be plugged into an outdoor GFI outlet (120V).
- D. Rotisserie Motor On/Off Switch:** Activates the rotisserie motor. Requires grill to be plugged into an outdoor GFI outlet (120V).
- E. Wheel:** Raise the grill rack by turning the wheel. Pull the front of the wheel downward for raising rotation.
- F. Front Cooktop Burner Control:** Controls the flame on the cooktop burner. The electronic ignition for the cooktop burners is activated by pressing in the cooktop burner control knob(s).
- G. Rear Cooktop Burner Control:** Controls the flame on the cooktop burner. The electronic ignition for the cooktop burners is activated by pressing in the cooktop burner control knob(s).

Before You Cook

A quick safety check should be performed before each time you use the grill.

1. Clean and inspect the gas hose. If there is evidence of abrasion, wear, cuts or leaks, do not use the grill. The hose must be replaced prior to using the grill. Replace the hose assembly with the exact type specified by Kalamazoo Outdoor Gourmet.
2. Ensure the gas hose is clear of the grill. Keep the fuel supply hose away from all surfaces of the grill.
3. Check that the area near the grill is clear of combustible materials and vapors, including alcohol, gasoline, aerosol containers and dry goods. Keep electrical cords from being in contact with any surfaces of the grill.
4. Do not use the grill when the wind is strong enough that it might blow hot embers from the fire toward combustible materials or structures.
5. Do not use the grill with overly loose-fitting clothing, especially loose sleeves that may come in contact with the hot surfaces inside or outside the grill.
6. Have insulated gloves with long cuffs ready and available.

While You are Cooking

1. Never move the grill while it is in use or when it is hot.
2. The use of alcohol, prescription or non-prescription drugs may impair your ability to properly assemble or safely operate the grill.
3. Do not touch the grill rack, any surfaces inside or around the firebox, the uprights or cross member while the grill is hot. These surfaces can cause serious burns.
4. Use caution when touching the wheel. The wheel can become hot under certain cooking and wind conditions. Insulated gloves are recommended.
5. **Always control the movement of the wheel when raising and lowering the grill rack.**
6. Be very careful transporting hot food. Sauces, juices and oils can cause serious burns to yourself or those around you.
7. Only use a brass bristle or stainless steel brush to clean the cooking surfaces. Wear insulated gloves with long cuffs to protect your hands.
8. Always keep the firebox chute above the ash pan closed when the grill is in operation. Never open the chute closure or empty the ash pan while the grill or the contents of the pan are hot. Always wait at least 24 hours after the grill has been hot before emptying the ash pan.



Follow all warnings and instructions when using this appliance.

This appliance is not intended for and should never be used as a heater.

This appliance is not intended for commercial use.

Lighting Your Grill

Before lighting your grill, be sure you have followed the instructions in this Use and Care Guide regarding proper setup, placement, gas connections leak testing and safe operation, all of which precede this page.

IMPORTANT: Do not use the grill if the odor of gas is present at any time. Follow leak testing procedures before using the grill.

Standard Lighting Procedure:

Starter Burners

1. Remove grill cover (Figure 15:Y).
2. Raise grill rack (Figure 7:B) so that you have a clearer view of the burners (Figure 8:D,G)
3. Make sure all control knobs (Figure 16:A,B,F,G) are in the OFF position.
4. Turn the main gas supply on.
5. Keeping your face well away from the firebox. Press in the REAR STARTER BURNER control knob (see Figure 16:B) for 5 seconds to activate the hot surface igniter (Figure 8:I). While continuing to press in the control knob, turn it to the HIGH position. Ignition should take place within 4 to 5 seconds. If the burner does not light within 4 to 5 seconds, turn the knob to the OFF position and wait 5 minutes for the gas to dissipate before trying again.
6. Repeat the process to light the front starter burner. Keeping your face well away from the firebox. Press in the FRONT STARTER BURNER control knob (see Figure 16:A) for 5 seconds to activate the hot surface igniter (Figure 8:F). While continuing to press in the control knob, turn it to the HIGH position. Ignition should take place within 4 to 5 seconds. If the burner does not light within 4 to 5 seconds, turn the knob to the OFF position and wait 5 minutes for the gas to dissipate before trying again.

Cooktop Burners

1. Remove the stainless steel cover from the cooktop burners (see Figure 12:S).
2. Make sure all control knobs are in the OFF position.
3. Turn the main gas supply on.
4. Keeping your face well away from the unit, press in the COOKTOP BURNER control knob (see Figure 16:F,G). You should hear a rapid clicking noise from the electronic ignition. While continuing to press in the control knob, turn it to the HIGH position. Ignition should take place within 4 to 5 seconds. If the burner does not light within 4 to 5 seconds, turn the knob to the OFF position and wait 5 minutes for the gas to dissipate before trying again. If you do not hear clicking from the electronic ignition system, refer to the troubleshooting section of this Use and Care Guide.
5. **NEVER PLACE THE COOKTOP BURNER COVER OVER THE COOKTOP BURNERS WHILE THE BURNERS ARE IN OPERATION.**

Manual Lighting Procedure:

Starter Burners

1. Remove grill cover (Figure 15:Y).
2. Raise grill rack (Figure 7:B) so that you have a clearer view of the burners (Figure 8:D,G)
3. Make sure all control knobs (Figure 16:A,B,F,G) are in the OFF position.
4. Turn the main gas supply on.
5. Keeping your face well away from the firebox. Insert the lit end of a long fireplace lighter or match through a rectangular fire port in one of the fire grates (Figure 9:J) near the rear starter burner (Figure 8:G). Press in the REAR STARTER BURNER control knob (see Figure 16:B) and turn it to the HIGH position. Ignition should take place within 4 to 5 seconds. If the burner does not light within 4 to 5 seconds, turn the knob to the OFF position and wait 5 minutes for the gas to dissipate before trying again.
6. Repeat the process to light the front starter burner. Keeping your face well away from the firebox. Insert the lit end of a long fireplace lighter or match through a rectangular fire port in one of the fire grates (Figure 9:J) near the front starter burner (Figure 8:D). Press in the FRONT STARTER BURNER control knob (see Figure 16:A) and turn it to the HIGH position. Ignition should take place within 4 to 5 seconds. If the burner does not light within 4 to 5 seconds, turn the knob to the OFF position and wait 5 minutes for the gas to dissipate before trying again.

Cooktop Burners

1. Remove the cover from the cooktop burners.
2. Make sure all control knobs are in the OFF position.
3. Turn the main gas supply on.
4. Keeping your face well away from the unit, hold a match or lighter wand at the side of the COOKTOP BURNER. Press in the COOKTOP BURNER control knob (see Figure 16:F), and turn it to the HIGH position. Ignition should take place within 4 to 5 seconds. If the burner does not light within 4 to 5 seconds, turn the knob to the OFF position and wait 5 minutes for the gas to dissipate before trying again.

FIGURE 17

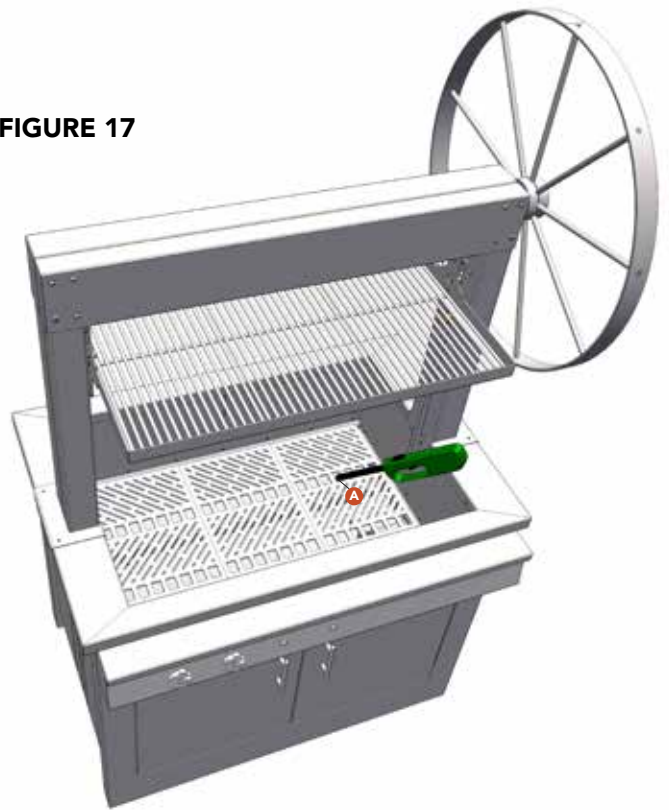

Ignition System Power Supply

The ignition system that lights the burners utilizes a hot surface electronic ignition system with an AC power supply. The ignition system for cooktop burners utilizes a AA battery to power an electronic spark ignition system.

Plugging in the Grill

A short, factory-supplied cord is connected to the grill's electronic control box inside the main cabinet below the grill (see Figure 12). Run a customer-supplied, single-plug, grounded, outdoor-rated extension cord into the grill cabinet through the opening in the floor pan that is protected by the rubber grommet. Connect the customer-supplied cord to the short, factory-supplied cord inside the cabinet.

Be certain to connect the power to a GFI outlet. Check that the grill's central system is receiving power by turning on the control panel lights (see Figure 16:C) or rotisserie motor (see Figure 16:D).

Changing the Cooktop Ignition System Batteries

The cooktop burners ignition is not connected to AC power. It runs on a single AA battery. Screw off the cap (see Figure 18:A) to replace the AA battery.

FIGURE 18

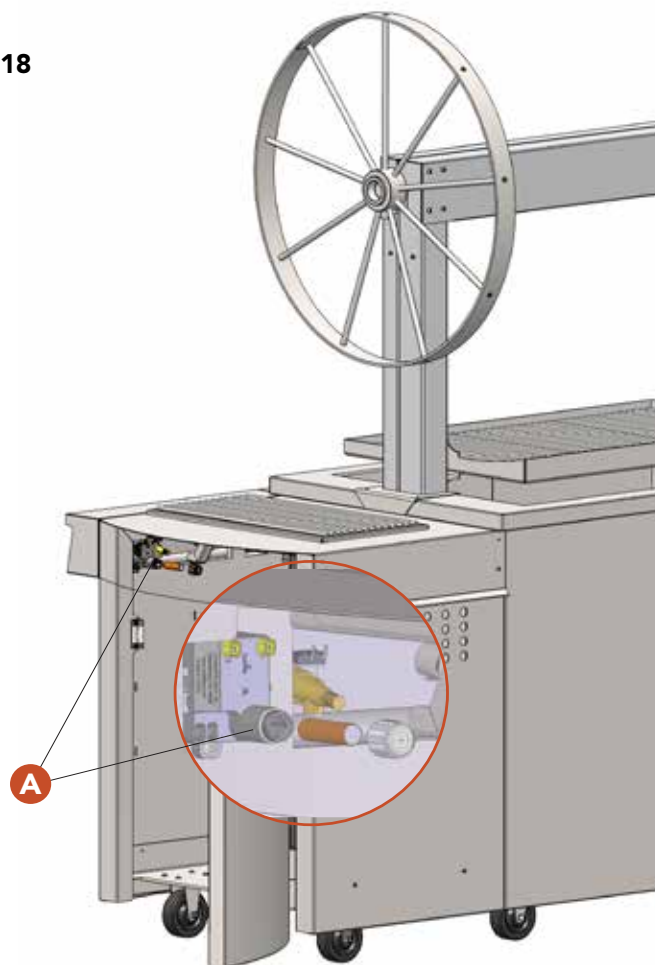

Flame Characteristics

Every burner is tested and adjusted at the factory for proper performance. If a burner is not operating properly, it may be due to variations in the local gas supply or because of an obstructed air shutter or orifice. Flames should be stable without lifting from the burner. The flames should burn cleanly without creating any sooty residue.

Starter Burner Flame Characteristics:

- The flame should be blue and stable with only a small amount of orange, if any, at the tips. There should be little noise and no lifting.
- On HIGH, the inner cone (Figure 19:A) should be approximately 3/8 inch long.
- On HIGH, the outer cone (Figure 19:B) should be nearly reaching the bottom of the fire grates (Figure 9:K)

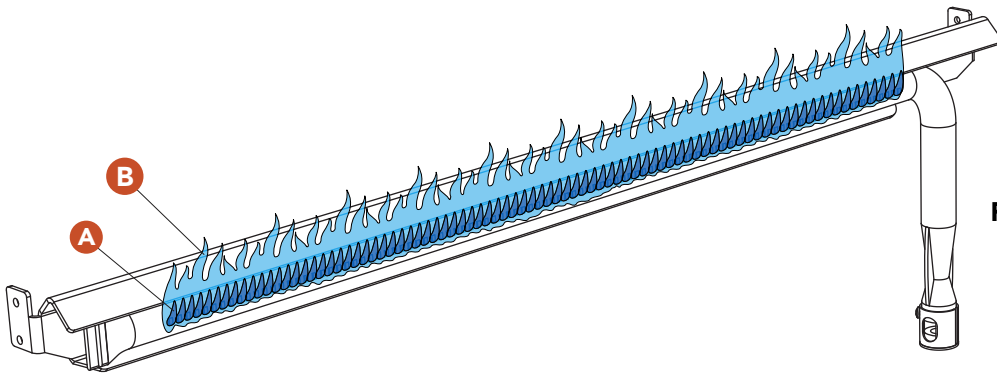

FIGURE 19

Visually compare the flames in your grill and adjust if necessary, using the instructions on the following pages.

Cooktop Burner Flame Characteristics:

- The flame should be blue and stable with only a small amount of orange, if any, at the tips. There should be little noise and no lifting.
- On HIGH, the inner cone (Figure 20:A) should be approximately 1/2 inch long.
- On HIGH, the outer cone (Figure 20:B) should be approximately 1 1/4 inches high.

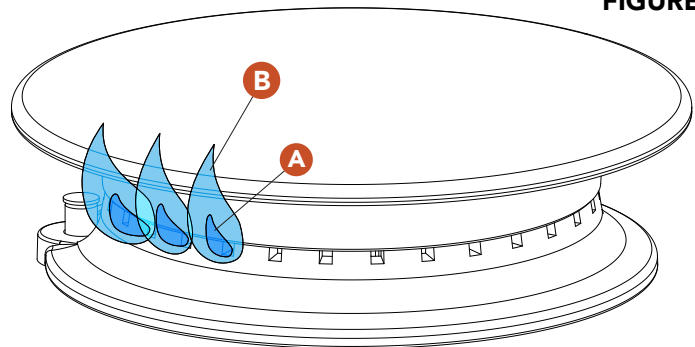

FIGURE 20

Burner Adjustments

IMPORTANT: A sooty flame is usually caused by dirt, debris or spider nests blocking the air shutter or orifice. This is a dangerous condition. The grill should NOT be used until the problem is rectified. If you are not comfortable addressing the issue yourself, please hire a qualified technician or contact Kalamazoo Outdoor Gourmet Customer Service at 1.800.868.1699.

To Adjust the Starter Burner Air Shutters:

The starter burner air shutters are easily accessed inside the base cabinet of the grill. Ensure the gas supply has been turned off at the source. Adjust the air shutters (Figure 21:A) by loosening the lock screw (Figure 21:B). The grill is factory adjusted so that the air shutter is about 50% open. If the flames are too orange, the burners may need more combustion air. Adjust the air shutter to a more open position.

Too much air may cause the flames to “lift off” the burner. This is a dangerous condition that must be avoided. Do not open the air shutter too far. Too much air will also make it more difficult to light the burner. You may test burn the grill to fine-tune the air shutter. Light only the burner to be adjusted and fine-tune the air shutter. Adjustments should be made with the burner on HIGH.

Once adjusted to a stable flame that burns cleanly and does not lift, turn the burner OFF. Tighten the lock screw.

To Clean the Ignition Burner Air Shutter:

Gently brush away debris from the screen (see Figure 27:C) using an old toothbrush.

Cooktop Burners Do Not Require Any Air Mixture Adjustment

To Adjust Burner LOW Settings (All Burners):

The low setting all burners can be adjusted using a long and thin flat-blade screw driver. First, light the burner and set it to LOW. Next, remove the control knob by pulling it outward until it slides off the valve stem. Insert the screw driver into the opening down the center of the valve stem and into the adjustment screw (Figure 22:A). Turn the adjustment screw until the flame on the burner is the minimum stable flame height. The flame should be steady at all ports around the burner. The flame should not be easily blown out without quickly reestablishing itself.

FIGURE 21

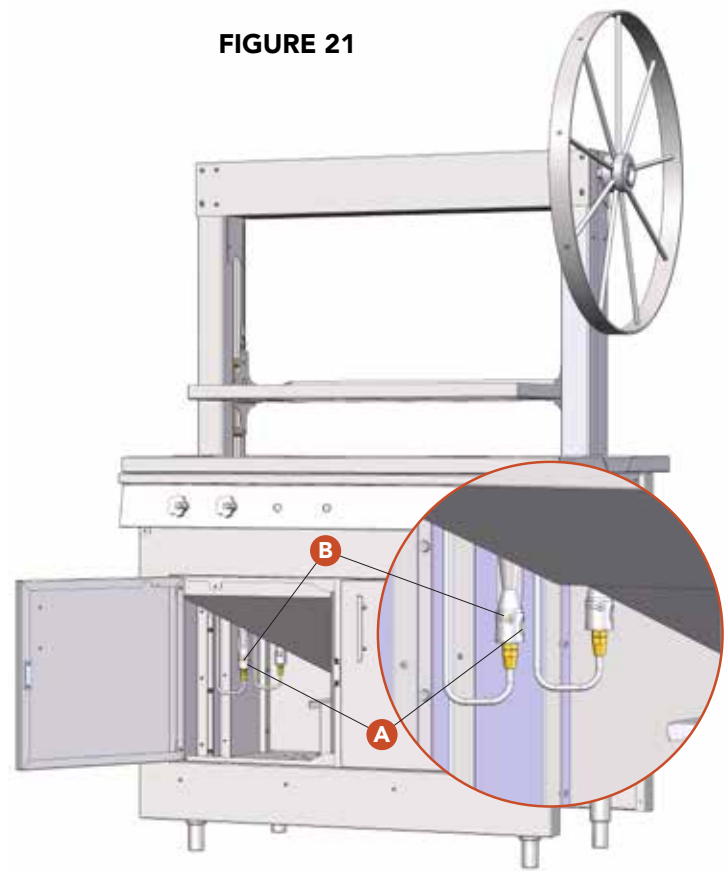
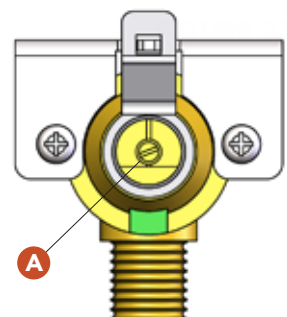

FIGURE 22



Cooking with Your Gaucho Grill

IMPORTANT: Kalamazoo Grills are high-performance pieces of equipment that get very hot. Use caution when working with the grill and do not leave the grill unattended. Use insulated gloves with a long cuff to protect your hands and forearms from heat.

Essential Equipment

- Leather insulated gloves with long cuffs to protect your hands and forearms
- Stiff, dense stainless steel brush for cleaning the cooking surfaces
- Long-handled grill tongs (18" long)

Other Helpful Accessories

- Cast iron skillets, dutch ovens, fajita pans and other cookware
- Thin and flexible turner for burgers and delicate fish fillets
- Silicon basing brushes
- Kalamazoo laser-cut custom grilling surfaces with patterns optimized for cooking meat, fish and vegetables

IMPORTANT: Before cooking, become familiar with all the information in this Use and Care Guide regarding safe operation of your grill.

Building a Wood Cooking Fire

- **Stacking the Wood:** Raise the grill rack (Figure 7:C) to a high position. We recommend a three-layer cooking fire for most cooking sessions. The three-layer wood stack may be confined to a single area of the grill if a full fire is not needed. Lay the first layer of hardwood limbs or splits so they run front-to-back on top of the fire grate (Figure 9:K). This orientation allows each piece of wood to ideally cross the fire of both starter burners. Leave room between each piece of wood (as shown) for air circulation. Lay the next layer of wood perpendicular to the first, leaving air space between the pieces. Lay the third layer perpendicular to the second (the same orientation as the first layer), again leaving spaces for air.

FIGURE 23

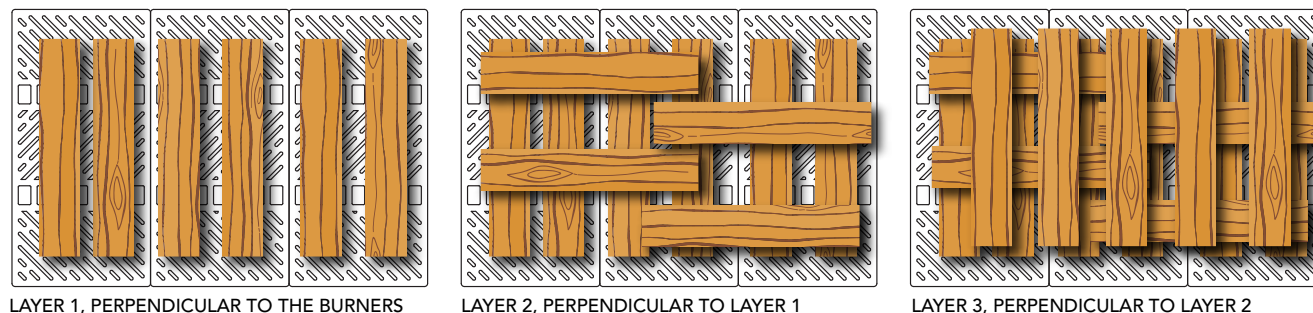

This three-layer configuration creates an ideal cooking fire that starts quickly and cooks for a long time. As the wood is consumed and turned to embers, the fire will collapse on itself into an even layer of coals across the fire grates. Maintain The heavy fire grates hold the heat of the embers while allowing airflow to keep them glowing.

- **Starting the Fire:** With the wood stacked and ready, fire up the starter burners (see lighting instructions) . A strong and self-sustaining fire should be going within 10 to 20 minutes. You can then turn off the starter burners.
- **Cooking Over the Fire:** Do not attempt to cook over a roaring fire. Cook over a bed of coals 2 to 3 inches deep, adding one or two pieces of wood at a time as needed to maintain the bed of coals. Place the food on the grill grate and/or the rotisserie spit to begin grilling. Control the intensity of the heat by raising and lowering the grill rack and the food above the coals. The closer the food is to the fire, the more intense the heat will be.

Food can be brought close to the coals to sear it on the outside and then raised higher to cook through gently. This technique can be used to sear steaks or to crisp up the skin of poultry on the rotisserie spit.

The cooking experience is engaging and involved as you get to know your grill and the characteristics of the wood fire.

- **Working with the Grill Grates:** The Kalamazoo Gaucho Grill comes standard with stainless steel rod grates. These may be exchanged for a laser-cut grill grate upgrade option, or the laser-cut grill grates can be purchased in addition. Argentinian-style "V" grates are also available. Your grill rack holds up to three grill grates, and you may cook with any combination of these options.



ARGENTINIAN-STYLE GRILL GRATE

The standard rod grates are quite heavy, but they hold less heat than the laser-cut grates. This allows them to cool more quickly when you raise the grill rack higher above the fire.

The laser-cut grill grates are available in three patterns optimized for a variety of foods and cooking. The "meat" pattern is the most open pattern with the most exposure to the fire. The "vegetable pattern" has opening sized specifically so that asparagus and green beans do not fall through. This is a great all-purpose pattern. The "fish" pattern is nearly solid. It supports delicate fish fillets, but is also perfect for finely-sliced onions and peppers or for Cajun-style blackening.

The Argentinian-style "V" grates have channels to direct drippings away from the fire and into small collection pans. These grates allow you to baste meats with their own drippings and create the least intense heat of the three styles.

- **Working with the Rotisserie Spit:** The spit can be used alone, or with one or two grill grates installed. This is perfect for grilling vegetables on a single grill grate section to complement a roast or bird nearly finished on the spit. You can remove all the grill grates to make more room on the spit as needed.

Food Temperature Chart

Beef Steaks	Gourmet	USDA
Rare	120°F	140°F
Medium-rare	130°F	150°F
Medium	140°F	160°F
Medium-well	150°F	170°F
Beef Roasts	Gourmet	USDA
Rare	125°F	140°F
Medium-rare	135°F	150°F
Medium	145°F	160°F
Medium-well	160°F	170°F
Beef Burgers	Gourmet	USDA
	160°F	160°F +
Lamb Racks	Gourmet	USDA
Rare	125°F	140°F
Medium-rare	135°F	150°F
Medium	145°F	160°F
Medium-well	160°F	170°F
Lamb Chops	Gourmet	USDA
Rare	125°F	140°F
Medium-rare	135°F	150°F
Medium	145°F	160°F
Medium-well	160°F	170°F
Pork Chops	Gourmet	USDA
Medium-well	160°F	-----
Well done	180°F	170°F
Veal Chops	Gourmet	USDA
Medium-rare	135°F	-----
Medium	145°F	150°F
Medium-well	160°F	160°F
Whole Chicken	Gourmet	USDA
	170°F	180°F
Whole Turkey	Gourmet	USDA
	170°F	180°F

Doneness of meat should always be determined using an instant-read meat thermometer inserted in the thickest part of the meat and away from the bone.

While USDA temperature guidelines are valuable for food safety, we find them often overdone, especially on the grill. Many restaurants cook to temperatures aligned more with the "gourmet" column shown here. This requires close attention to safe food-handling guidelines.

Rolled Beef Roasts

As with ground meat, surface bacteria may get worked into the center of rolled beef roasts. Therefore, they should be cooked to an internal temperature of 160°F.

Fish

Fish is thoroughly cooked when it turns opaque and the meat flakes cleanly under firm pressure.

Shrimp and Lobster Tails

Shrimp and lobster are fully cooked when the flesh turns opaque.



Subscribe for recipes at KalamazooGourmet.com.

Caring for Your Grill

Your Kalamazoo Outdoor Gourmet grill is made from high-quality 304 stainless steel and engineered for durability. Simple care and cleaning will provide a lifetime of service...

Grilling Surfaces

Before each cooking session, after the grill has pre-heated, use a stiff stainless steel grill brush to clean the grilling surface.

ALWAYS use a stainless steel bristle brush for cleaning your grilling surface. Do not use brushes or scrapers of other metals with the exception of brass. Brass grill brushes will not harm your grilling surface, but we find that stainless steel brushes last much longer and are a better investment.

NEVER use steel wool on your cooking surfaces. It will leave small amounts of mild steel behind, embedded into the grain of the stainless steel, and it will cause rust.

NEVER use chemicals to clean your grilling surface.

Special Instructions for Laser-cut Grilling Surfaces

Your laser-cut surfaces should be kept clean, dry and BLACK. Treat them as you would a cast iron skillet. The darker the finish, the better.

Before using your surfaces for the first time, they need to be seasoned with oil. Remove the cold surfaces from your grill and use a cloth rag to wipe vegetable oil over the entire surface of each. Place the surfaces back into the grill and start your fire. The goal is to turn the surfaces brown. The more you use your grill, the more thoroughly seasoned your surfaces will become. Ideally you want your surfaces to become black and remain that way. You can re-season your surfaces at any time. Re-seasoning may be necessary if your grill sits idle for long periods of time.

Exterior Cleaning

The most difficult part of cleaning your grill is removing the burnt-on food and grease. Start by using a citrus-based or organic degreaser to remove everything that isn't burnt on. Next, we recommend using powdered Bar Keepers Friend with a microfiber cloth and water. Be careful to follow the grain direction of the stainless steel to avoid scratches. With a little elbow grease, Bar Keepers Friend will remove most stains and discoloration. For real problem areas, a Scratch-B-Gone kit can be used to restore the factory finish. After these steps, rinse off all cleaners, wait for the grill to dry, and then apply stainless steel polish.

Saltwater Environments

Oceanfront environments with salt air and sea spray will require regular maintenance and cleaning to prevent rust. Clean stainless steel surfaces at least two times a month to keep the chemical reaction from the salt from gaining a foothold on your equipment. With regular cleaning, your equipment will look like new for a lifetime. To achieve maximum corrosion and stain resistance, the surface of the stainless steel must be kept clean. Should some rust spots occur, they can be easily removed with Bar Keepers Friend.

Interior Cleaning

WARNING: The cleanout bin gets extremely hot when the grill oven is operating. Empty the bin only when the grill and bin are completely cool.

Empty the ash bin before each use, but always be sure the grill and any leftover wood/embers are completely cool. Open the chute (Figure 11:P) and let the ash fall into the cleanout bin. You may occasionally wish to remove the fire grates and thoroughly sweep ash down into the bin.

Dispose of the ash in an appropriate container, reposition the ash collection bin and close the firebox chute before grilling.

Caring for Your Grill CONTINUED

Starter Burner Care

Visually inspect the burners once a year by removing the fire grates and using a mirror to check out the length of each burner and all of the ports. The burners are simple to remove, but it is not necessary to do so unless you find a problem. The burners should be structurally sound and all ports should be clear of any blockage.

If it is necessary to remove the burners, first make sure the grill is completely cooled. Ensure the grill control valves are in the OFF position and turn off the main gas supply. Release the burner from the gas line inside the cabinet by disconnecting the flex line connection (Figure 26:B) from the threaded end of the burner (Figure 26:A). Next, remove the access covers by removing screws (Figure 25:B). Then, remove screws (Figure 25:A) to release the burner bracket. Finally lift the burner, on its bracket, straight up until free of the grill.

When reinstalling burner, secure burner and bracket back into position (Figure 25:A), replace access covers (Figure 25:B). Take extreme care to fully thread gas line (Figure 26:B) back onto burner end (Figure 26:A).

Orifice Cleaning:

Clogged orifices create a dangerous condition that must be resolved before the grill may be used. If you are not entirely comfortable with the procedure, please use a qualified technician or contact Kalamazoo Outdoor Gourmet customer service at 1.800.868.1699.

To clean and inspect the starter burner gas orifices, you need to disassemble the connection at the air shutter, which is in the cabinet below the grill. First disconnect the flex line connection (Figure 24:A). Use care not to twist the flex line. Next, disconnect the orifice holder (Figure 24:B) from the threaded end of the burner (Figure 24:C). Finally, remove the spud orifice (Figure 24:D) from the orifice holder. Inspect all parts to ensure they are free of any blockage. Use extreme care not to enlarge the orifice hole while cleaning.

Reassemble the orifice holder and reconnect orifice holder assembly to the end of the burner taking care that it is fully secured. Reconnect the flexline, taking care not to twist the line.

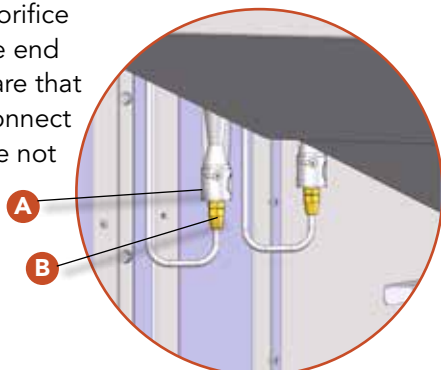

FIGURE 26

FIGURE 24

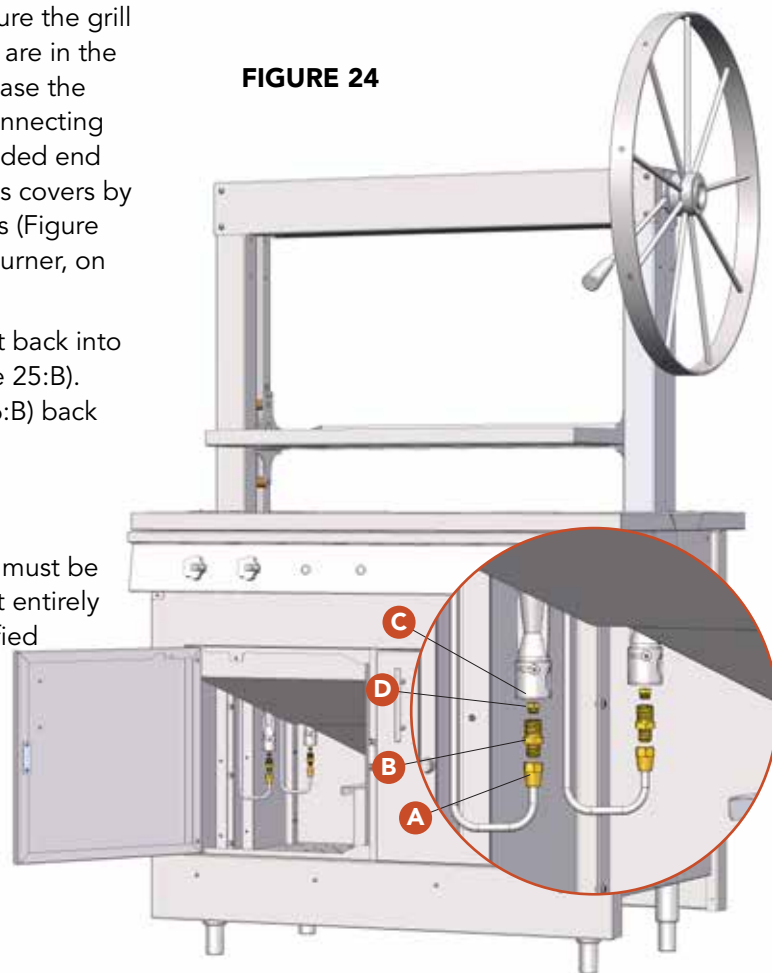
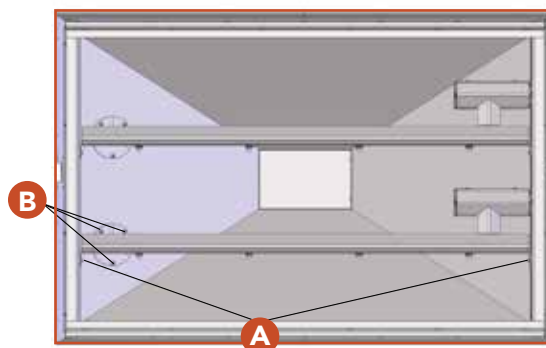

FIGURE 25



Troubleshooting

The troubleshooting tips here are for general information only. The information may save you the trouble of a service call. If your grill requires service, contact Kalamazoo Outdoor Gourmet customer service at 1.800.868.1699.

Grill won't light:

- **Starter burners:** Does the hot surface igniter (Figure 8:G,J) when you press in and hold the control knob? If not, do you have the grill plugged in to an AC outlet?
- If one or neither hot surface igniter is glowing, call Kalamazoo Outdoor Gourmet customer service. If the igniters glow, but the burner won't light, verify that it is an ignition problem and not a gas problem by manually lighting the ignition burner (see page 25).
- **Cooktop burners:** The cooktop burners utilize a separate ignition system from the main grill area. They are lit by a battery-powered electronic spark ignition. If you do hear rapid clicking when you press in the control knobs, but the burners won't light, try manually lighting the burners (follow the instructions on page 25). If the burners do not light manually, there is probably a gas problem and not an ignition problem. Call Kalamazoo Outdoor Gourmet customer service.

Burner flame won't start the wood fire:

- If the starter burners do not ignite a cooking fire (Figure 29) built with dry wood in less than 20 minutes, your grill might not be getting hot enough. On HIGH, the flames on the starter burners should nearly reach the bottom of the fire grate (Figure 19). If they do not, check the following:
 - LP cylinder has enough gas to deliver proper pressure. Refill the tank if necessary. In some situations in cold ambient temperatures, an LP cylinder will ice up, creating a drop in pressure. If this happens, turn off the tank and let it warm up before trying again. A full tank is less likely to ice up than a tank that is less than half full.
 - Main gas supply is fully on and not only partially opened.
 - Orifices are clear and not clogged. A clogged orifice creates a dangerous situation. Do not use the grill until the issue has been resolved (see page 33).
- If the fuel has been switched from liquid propane gas to natural gas, part of the process to convert the oven includes larger orifices. It is not safe to burn natural gas with liquid propane orifices (neither is it safe to burn the other way around). If you suspect a conversion was done improperly, do not use the grill and contact Kalamazoo Outdoor Gourmet customer service at 1.800.868.1699.

You smell gas:

- Turn off the grill immediately. Follow the leak check procedures on page 9. Contact Kalamazoo Outdoor Gourmet customer service at 1.800.868.1699 for assistance.



K750G Series Wiring Diagram

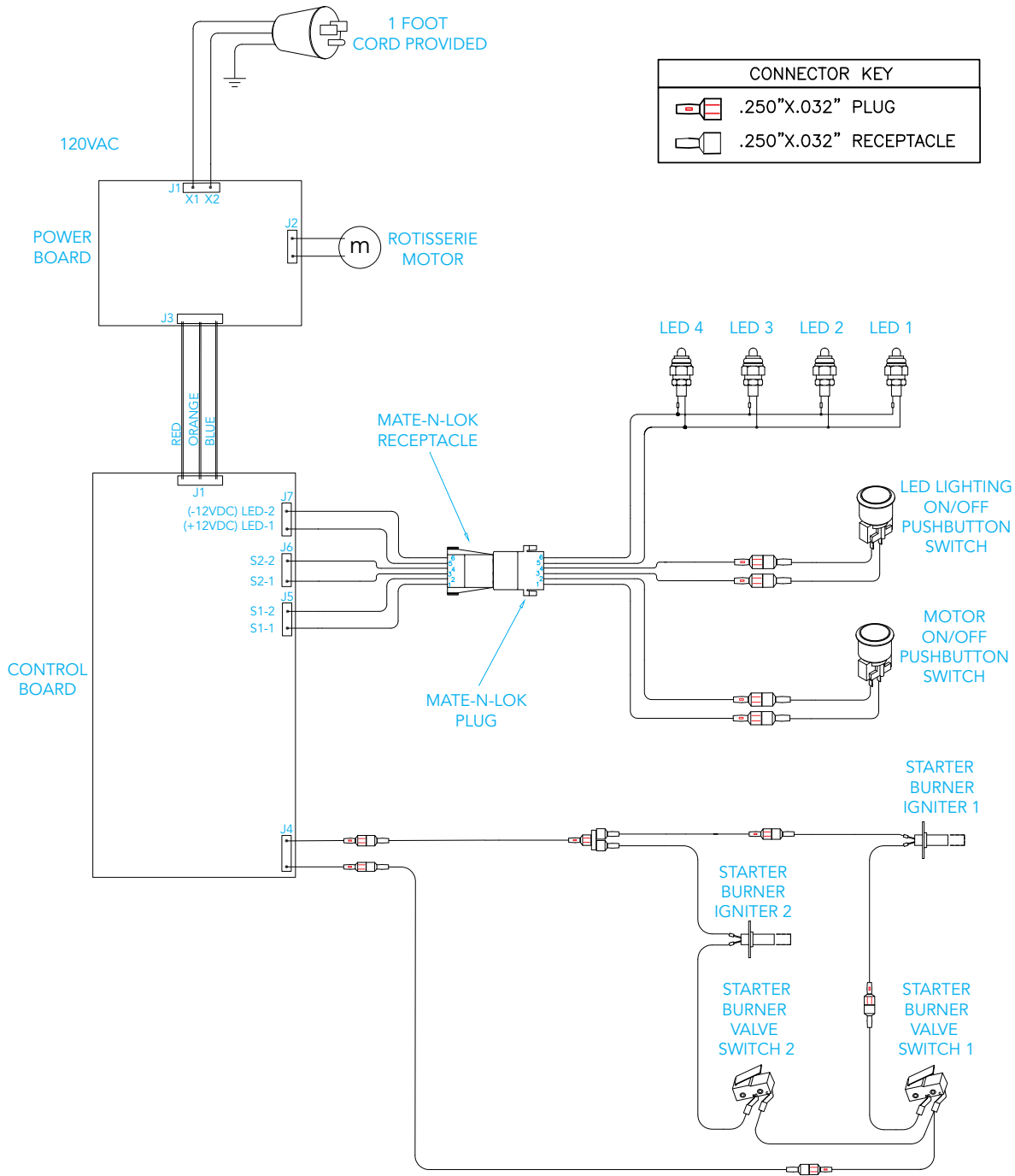

Side Cabinet Lighting Wiring Diagram

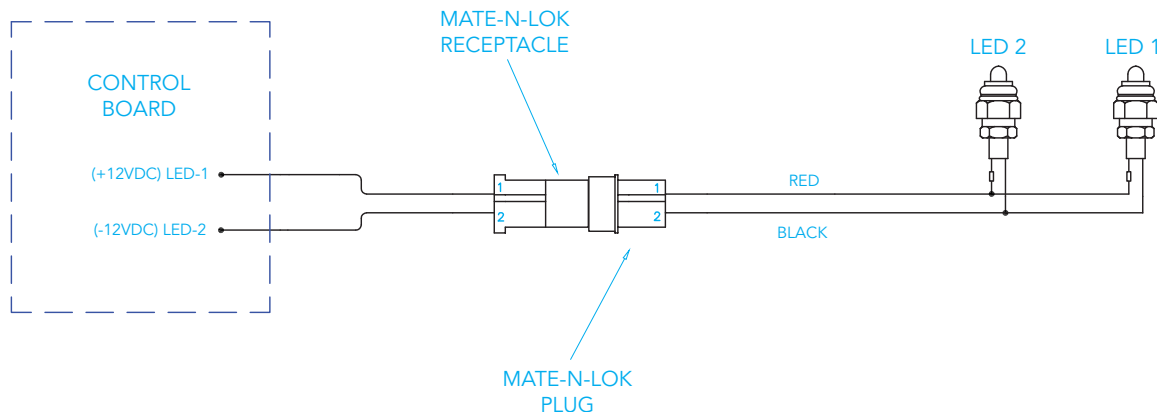

- The side cabinet on the K750GS model features LED control panel lighting the same as the main control panel. The Cabinet is factory installed on the grill, and the wiring harness for the lighting is factory connected to the main control board.



ELECTRICAL PRECAUTIONS:

- 1. To protect against electric shock, do not immerse cord or plugs in water or other liquid;**
- 2. Unplug from the outlet when not in use and before cleaning. Allow to cool before putting on or taking off parts;**
- 3. Do not operate any outdoor cooking gas appliance with a damaged cord, plug, or after the appliance malfunctions or has been damaged in any manner. Contact the manufacturer for repair;**
- 4. Do not let the cord hang over the edge of a table or touch hot surfaces;**
- 5. Do not use an outdoor cooking gas appliance for purposes other than intended;**
- 6. When connecting, first connect plug to the outdoor cooking gas appliance then plug appliance into the outlet;**
- 7. Use only a Ground Fault Interrupter (GFI) protected circuit with this outdoor cooking gas appliance;**
- 8. Never remove the grounding plug or use with an adapter of 2 prongs; and**
- 9. Use only extension cords with a 3 prong grounding plug, rated for the power of the equipment, and approved for outdoor use with a W-A marking.**



Kalamazoo Accessories

Sunbrella® Grill Covers A tailored cover is available for each model made from durable and fade-resistant black Sunbrella fabric with a silver Kalamazoo Outdoor Gourmet logo.

Grill Master's Essential Accessories Long-cuffed leather gloves and precision 16-inch tongs both protect your hands above a hot grill while the embroidered apron protects your wardrobe.



Steak Champ Electronic Steak Thermometers Our electronic thermometer eliminates the guesswork and manages the numerous variables to help you serve masterfully-grilled steaks every time.

All accessories can be ordered by calling 800.868.1699 or purchased online at KalamazooGourmet.com.



Installation Checklist

Installer should initial next to each item:

- Specified clearances maintained.
- No overhead combustible structure.
- Initial assembly completed — all tape and internal packaging removed (see Figure 5):
 - Wheel installed
 - Ash pan installed and firebox chute closure installed
 - Control knobs installed
 - Rotisserie rod and forks installed
 - Primary cooking grates installed
 - Cooktop burner diffuser caps installed (model-dependant)
 - Cooktop burner grate installed (model-dependant)
 - Cooktop cover installed (model-dependant)
- Grill connected to grounded, outdoor-rated extension cord and GFI circuit.
- Hot surface igniters for starter burners glow when control knobs are held in on AC power.
- Control panel lights working.
- Rotisserie motor working.
- Each burner control valve low setting adjusted to minimum stable flame height.
- Starter burners light within 4 to 5 seconds following lighting procedure.
- Cooktop burners (model-dependant) light within 4 to 5 seconds following lighting procedure.
- External manual shut-off valve is installed and accessible.
- Homeowner informed of external shut-off valve location as well as shut-off valve inside grill (model-dependant).

- Unit and supply connections have been tested and are free of leaks:
 - LP cylinder connected to dual-stage regulator at 11" WC
 - OR
 - Bulk LP supply regulated to 11" WC
 - OR
 - Natural gas supply at 7" WC
- Raising and lowering grill rack operation is smooth.
- Leave this Use and Care Guide with the homeowner.

HOMEOWNER: Please ensure the installer completes the checklist, explaining each item to you. The installer should initial each item above and sign below.

Installer Signature

Date

All specifications and other information contained in this Use and Care Guide are based on the latest product information available at the time of printing. Because Kalamazoo Outdoor Gourmet is always focused on product improvement, we reserve the right to make changes at any time. This includes all specifications of the product.

© 2015 Kalamazoo Outdoor Gourmet, LLC. Not to be reproduced wholly or in part without specific written permission from Kalamazoo Outdoor Gourmet, LLC.

Kalamazoo Outdoor Gourmet

Chicago Headquarters
810 W Washington Boulevard
Chicago, IL 60607

Michigan Plant
8566 Krum Avenue
Galesburg, MI 49053

1.800.868.1699

KalamazooGourmet.com

Replacement parts can be ordered from Kalamazoo Outdoor Gourmet Customer Service. Email customerservice@kalamazoooutdoor.com or call 800.868.1699.

