



# INSTALLATION INSTRUCTIONS

## PRO-SERIES HALOGEN, PRO-SERIES XENON UNDERCABINET LIGHT Juno Series Low Voltage ULH Halogen or UPX Xenon Luminaires

For use with 120V, 60Hz electrical power supply only. **WARNING: TO PREVENT OVERHEATING AND ELECTRICAL SHOCK DO NOT INSTALL IN SMALL ENCLOSED SPACES. TO PREVENT ELECTRICAL SHOCK DO NOT INSTALL IN WET ENVIRONMENTS.**

### IMPORTANT SAFETY INSTRUCTIONS

1. Read all of these instructions before installing fixture.
2. Keep these instructions in a safe place for future reference
3. Only qualified electricians in accordance with local codes should perform all installations.
4. **WARNING: FOR HARD WIRE INSTALLATION (NM & BX) MAKE SURE ELECTRICAL POWER SUPPLY FOR INSTALLATION CIRCUIT IS SHUT DOWN AT ELECTRICAL SERVICE PANEL BEFORE STARTING INSTALLATION. DO NOT RE-ENERGIZE CIRCUIT UNTIL INSTALLATION IS FULLY COMPLETED.**
5. Fixture is designed to be electrically grounded for hard wire (NM & BX) installations. **WARNING: TO PREVENT SHOCK CLOSELY FOLLOW GROUNDING DIRECTIONS.**

4. Using strip length guides on PUSH-IN WIRE CONNECTOR make sure lengths of exposed wire on supply cable are correct.
5. Insert each of the three wires from the NM supply cable into each of the three PUSH-IN WIRE CONNECTORS with respective color wires. Black to black, white to white, and green (or bare copper wire) to green. Make sure that feed wires are securely gripped by the PUSH-IN WIRE CONNECTOR and that with the exception of a bare ground wire, none of the supply wires show exposed wire where they enter the PUSH-IN WIRE CONNECTOR.
6. Neatly push wires and PUSH-IN WIRE CONNECTORS into opening in back of the fixture.
7. Properly engage ROMEX PLATE in back of fixture and tighten screw. Do not over tighten screw. Make sure that lock washer is installed under head of screw for proper grounding.

### SAVE THESE INSTRUCTIONS

#### WAYS TO ELECTRICALLY FEED FIXTURE

Electrical power can be brought to the fixture using different techniques:

- Non-Metallic Cable (NM) using ROMEX PLATE (provided and mounted on fixtures).
- Armored Cable (BX) using optional CONDUIT PLATE and die-cast aluminum electrical connector (provided loose).
- Connections can also be made using fixture knockouts (2 & 3 lamp units) and connector supplied loose.
- Wiring module accessory ULH-DWM (sold separately) can be used for forward mount applications if necessary to allow for remote supply wiring.

#### WIRING CONNECTIONS - Non-Metallic Cable (NM)

1. Loosen screw on ROMEX PLATE and remove.
2. Push NM supply cable through rectangular wire grip in plate so outer jacket of cable projects about 3/4" through plate.
3. Inside fixture are three wires with PUSH-IN WIRE CONNECTOR fitted to each end. Carefully pull these out of fixture. Do not pull with excessive force.

#### WIRING CONNECTIONS - Armored Cable (BX)

1. Loosen screw on ROMEX PLATE. Remove plate and discard.
2. Mount die-cast aluminum electrical connector to the flat side of the CONDUIT PLATE. Securely tighten nut.
3. Push BX cable into connector. Make sure BX cable has a properly installed plastic insulating bushing (not provided). Tighten clamp screws securely making sure that BX cable remains fully seated in connector during tightening.
4. Perform steps 3-7 (above, for NM cable).  
NOTE: In some BX installations there may not be a separate grounding wire provided. Grounding is achieved through the spiral wound metal jacket of the BX cable.  
NOTE: The die-cast aluminum connector can also be used with NM cable if desired.  
NOTE: 2 die-cast connectors can be used for loop feed supply wiring (2 & 3 lamp units) if desired. (For 2nd die-cast connector, order accessory ULH-CONN.)

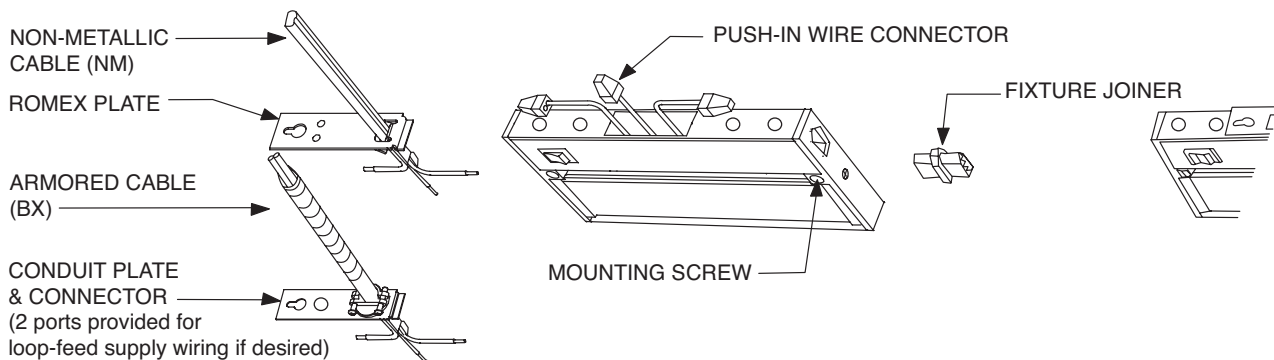



# INSTALLATION INSTRUCTIONS

## PRO-SERIES HALOGEN, PRO-SERIES XENON UNDERCABINET LIGHT Juno Series Low Voltage ULH Halogen or UPX Xenon Luminaires

### FIXTURE DIMMING

Fixtures may be used with quality household dimmers or a dimmer system designed for non-inductive loads. For best dimming performance, use dimmer systems specifically designed for low voltage electronic transformers.

### MOUNTING FIXTURE

1. Place fixture in desired position.
2. Drive fixture MOUNTING SCREWS securely. Mounting screws are suitable for cabinet bottoms 3/8" or thicker. Use shorter screws for cabinet bottoms thinner than 3/8".
3. In some installations it may be desired to drill a pilot hole for the screws. Place the fixture in the desired position and drive MOUNTING SCREWS a small amount to impart a small reference point for drilling.
4. Make sure that all unused electrical ports on the ends of the fixture are safely protected with ELECTRICAL PORT COVERS (two provided with each fixture).
5. Re-energize electrical circuit at service panel.
6. Fixture has a three-position switch: HIGH/OFF/LOW.

### JOINING MULTIPLE FIXTURES

1. **WARNING: IN MULTIPLE FIXTURE INSTALLATIONS DO NOT ELECTRIFY FIXTURE GROUP UNTIL ALL ELECTRICAL CONNECTIONS HAVE BEEN SECURELY MOUNTED. ELECTRICAL PORT COVERS MUST BE INSTALLED IN ALL OPEN PORTS AT THE COMPLETION OF INSTALLATION.**
2. Fixtures can be joined together using FIXTURE JOINER (one provided with each fixture) or with JUMPER CORD accessory (Cat. No. JC3, sold separately).
3. **WARNING: THE TOTAL NUMBER OF FIXTURES THAT CAN BE JOINED TOGETHER AND POWERED FROM ONE ELECTRICAL FEED PORT IS GOVERNED BY THE NUMBER OF 20W LIGHT BULBS PER ELECTRICAL FEED POINT (600W MAXIMUM).**
4. First mount fixture that receives incoming electrical supply. With a small screwdriver remove ELECTRICAL PORT COVERS as needed. When using FIXTURE JOINER to add fixtures make sure JOINER is fully seated in both fixtures. Fixtures should fit fully and squarely end-to-end when mounting is complete.

5. When using JUMPER CORD accessory, make sure plugs on both ends are fully inserted into ports on both fixtures. There should be some slack in the JUMPER CORD so that the electrical connections are not stressed in any way. Use cord clips (provided), as desired, to keep cord safely snug to mounting surface.
6. **WARNING: DO NOT USE JUMPER CORD AS A MEANS TO TURN FIXTURES ON AND OFF.**

### LIGHT BULB REPLACEMENT AND LENS CLEANING

1. Before opening fixture make sure it has fully cooled down.
2. Turn off electrical power at service panel.
3. Lower lens by pushing LENS RETENTION BAR towards rear of fixture. Lens will swing downward.
4. Replacement light bulbs: Use only 12V, 20W Halogen lamps for Pro-Halogen Series. Use only 12V, 20W bi-pin Xenon lamps for Pro-Xenon Series. **WARNING: USE OF HIGHER WATTAGE BULBS CAN CAUSE OVERHEATING, DAMAGE TO FIXTURE AND SURFACE TO WHICH IT IS MOUNTED.**
5. Do not handle Halogen bulbs with bare fingers. Use packaging provided with bulb or a clean cloth to hold bulb for insertion into socket. If bulb is touched, clean with rubbing alcohol.
6. Re-seat lens by pushing upward while simultaneously pushing LENS RETENTION BAR rearwards.
7. Lens can be fully removed for bulb replacement or cleaning by performing Step 3, above. Then while lens is in straight down position, grasp right side lens end cap and push rearward about 1/4". Pull down and remove lens.
8. Clean lens only with warm water and a mild detergent solution. Do not use abrasive powders or petroleum solvents to clean lens. Dry lens completely before re-inserting into fixture.
9. Replace lens by first inserting pin into hole in left side of fixture. Push right pin up into slot on right side of fixture and pull lens forward about 1/4" until it stops. Swing lens back and up into fixture while simultaneously pushing LENS RETENTION BAR rearward. (Note: replacement lens available from factory.)

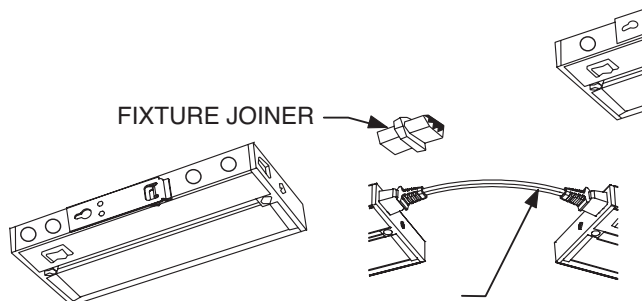

JUMPER CORD AVAILABLE IN 8", 17" AND 26" LENGTHS. BLACK OR WHITE FINISH. (order separately)

ELECTRICAL PORT COVERS MUST BE INSTALLED IN ALL OPEN PORTS AT COMPLETION OF INSTALLATION

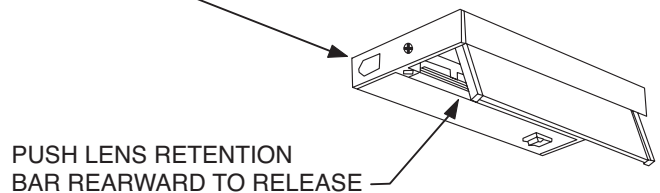

PUSH LENS RETENTION BAR REARWARD TO RELEASE

Product Services Phone (888) 387-2212

1300 South Wolf Road • Des Plaines, IL 60018 • Phone 800-323-5068 • www.junolightinggroup.com



JUNO LIGHTING GROUP  
an AcuityBrands company