



www.johnsonhardware.com

INSTRUCTIONS

2000 SERIES POCKET DOOR FRAME

2000 MADE FOR 2" X 4" STUD WALLS

For a 1-1/8" (29mm) to 1-3/4" (45mm) Doors weighing up to 400 lbs. (182kg) each.
Para puertas de 29mm o 45mm y de hasta 182kg cada uno.
Pour porte de 29mm ou 45mm pesant jusqu'à 182kg chaque.

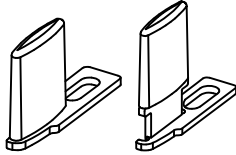

INCLUDES OPTIONAL 2041 HIDDEN GUIDE

2000 SERIES SET NUMBERS AND SIZES

**202668PF FOR 1- 30" (761mm) X 80" (2.03m) Door, Puerta, Porte

**203068PF FOR 1- 36" (913mm) X 80" (2.03m) Door, Puerta, Porte

**All purpose frames, marked to cut to shorter lengths.

**Marcos universales, marcados para ser cortados a longitudes menores.

**Montants à usage multiple, marqués pour être coupés plus court.

CONVERGING DOORS REQUIRE TWO FRAMES AND THE 2050 CONVERGING DOOR KIT.

Frames for Doors up to 60" (1.27m) wide and 108" (2.74m) high are available.

Hay marcos disponibles para Puertas de hasta 1,27m de ancho 2,74m de alto.

Des montants pour Portes jusqu'à 1,27m en largeur et 2,74m en hauteur sont disponibles.

NOTE: Instructions are for a 80" (2,03m) door, if door is shorter, lower header and cut bottom ends of Split Studs, if door is taller than 80" (2m), order longer Split Studs and raise header.

NOTA: Las instrucciones son para una puerta de 2,03m. Si la puerta es mas corta, baja la cabecera y corte los extremos de abajo de las jambas divididas. Si la puerta es más alta que 2,03m, ordene piezas verticales más largas y suba la cabecera.

NOTE: Les instructions se réfèrent à la porte de 2,03m, Si la porte est plus petite, abaissez le guide et coupez les extrémités des montants de séparation. Si la porte est haute que 2,03m, commandez des montants plus longs et rehaussez le guide.

1 **CONSTRUCT ROUGH OPENING** Header must be **SQUARE** and **PLUMB** with studs and **LEVEL**. Minimum Height is 86-3/4" (2,2m) width is 2X Door width plus 1" (25mm).

CONSTRUYA LA ABERTURA PRELIMINAR. La cabecera debe de estar en **ESCUADRA** y **A PLOMO** con los montantes y a **NIVEL**. La Altura Mínima es de 2,2m, el Ancho es de 2X Ancho de Puerta mas 25mm.

CONSTRUISEZ L'OUVERTURE BRUTE. Le guide doit être perpendiculaire et d'aplomb avec les montants ainsi qu'à niveau. La hauteur minimale est de 2,2m. La largeur correspond à 2X porte plus 25mm.

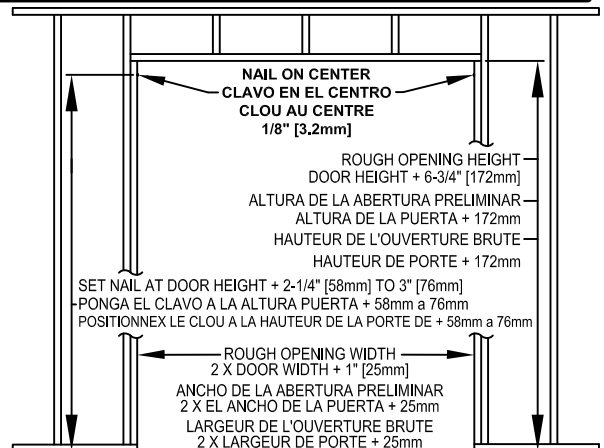

2 **Measure** up from finished floor 82-1/4" (2.08m) or from sub-floor to 83" (2.11m). This will give 3/4" (19mm) to 1-1/2" (38mm) clearance under door. Mark each rough stud and drive a flat head nail on center, leaving 1/8" (3mm) protruding. (Frame header end brackets will rest on these nails).

Mida 2.09m desde el piso terminado ó 2.11m desde el sub-piso. Esto dará una separación de 19mm hasta 38mm debajo de la puerta. Marque cada montante y clave un clavo de cabeza plana en el centro de cada una, dejando 3mm afuera, (Los soportes de los extremos de la cabecera del marco se apoyaran en estos clavos).

Mesurez 2,09m à partir du sol fini ou bien 2,11m à partir du sous plancher. Ce qui va donner un jeu de 19mm à 38mm sous la porte. Marquez chaque montant et enfoncez un clou à tête plate au centre, en laissant dépasser 3mm. (Les crochets du linteau reposeront sur ces clous).

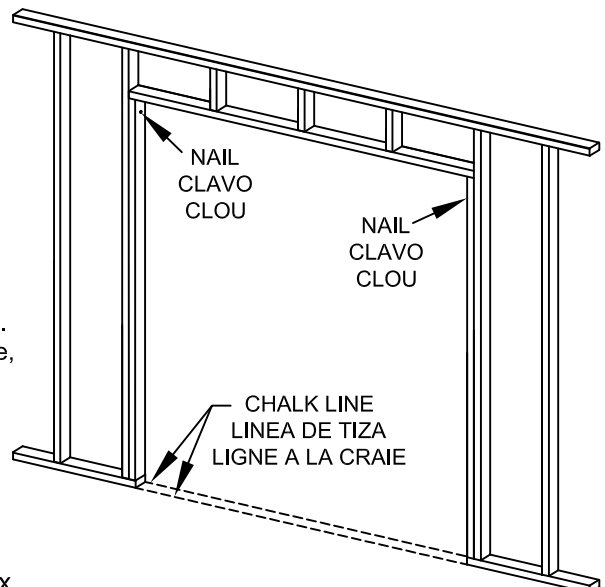

3 **Snap** a chalk line on floor even with side jamb.

Marque una linea con un cordel entizado en el piso que concuerde con las jambas laterales.

Tracez à craie une ligne au sol parallèle aux montants latéraux.

- 4** Slip slots in Frame Header End Plates over nails in rough studs. LEVEL HEADER. Set nails and drive nails through remaining holes in end plates. (If you have the 2/6" (761mm) or Universal Frame and using another size door, see cutting instructions on page 4.)

Encaje la ranuras que estan en las Placas de los Extremos de la Cabecera del Marco en los clavos que estan en los montantes. Alinee los clavos y clavos en los orificios restantes en las placas de los extremos. (Si usted tiene el Marco de 761mm o el Marco Universal y esta usando puerta de otro tamaño, vea las instrucciones de corte en la página 4.)

Glissez les encoches des extrémités du linteau sur les clous fixés dans les montants bruts. Mettez le guide à niveau. Positionnez les clous et enfoncez les au travers des trous restants dans les plaques des extrémités. (Si vous avez le montant universel ou de 761mm et utilisez une dimension de porte différente, référez vous aux intructions de coupe page 4.)

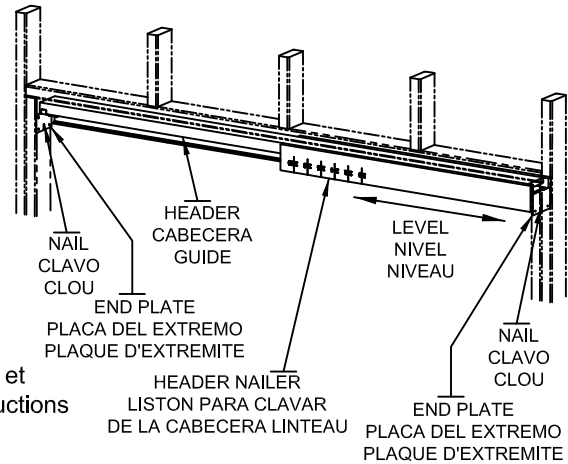

- 5** Slip fingers of Floor Plate into Split Steel Studs as shown. Butt Split Steel Studs against header nailer and screw into place with two (2) 3/4" (19mm) X #8 Pan Head Screws. Attach other Split Steel Studs midway in "Pocket" opening. Plumb Split Steel Studs between chalk lines and nail to floor. (On masonry, use industrial adhesive or Tapcon fasteners.)

Encaje las aletas de la Placa del Piso en las Jambas Divididas tal como se muestra. Una a tope las jambas divididas contra el listón para clavar de la cabecera y atornillelas en su sitio con dos (2) tornillos de cabeza troncocónica #8 X 19mm. Coloque otras jambas divididas en un lugar intermedio de la abertura de la "Cavidad". Alinee a plomo las jambas divididas entre las líneas de tiza y clávelas al piso. (En el caso de mampostería, use un adhesivo de tipo industrial o sujetadores Tapcon.)

Glissez tel qu'illustré les doigts de la plaque de plancher dans les montants de séparation. Calez ces derniers contre le linteau et fixez en place à l'aide de deux (2) vix No. 8 à tête tronconique de 19mm. Attachez le second montant de séparation au centre de l'ouverture de la poche. Mettez d'aplomb les montants de séparation entre les tracés de craie et clourz au sol. (Sur de la maçonnerie, utilisez un adhésif industriel ou de boulons Tapcon.)

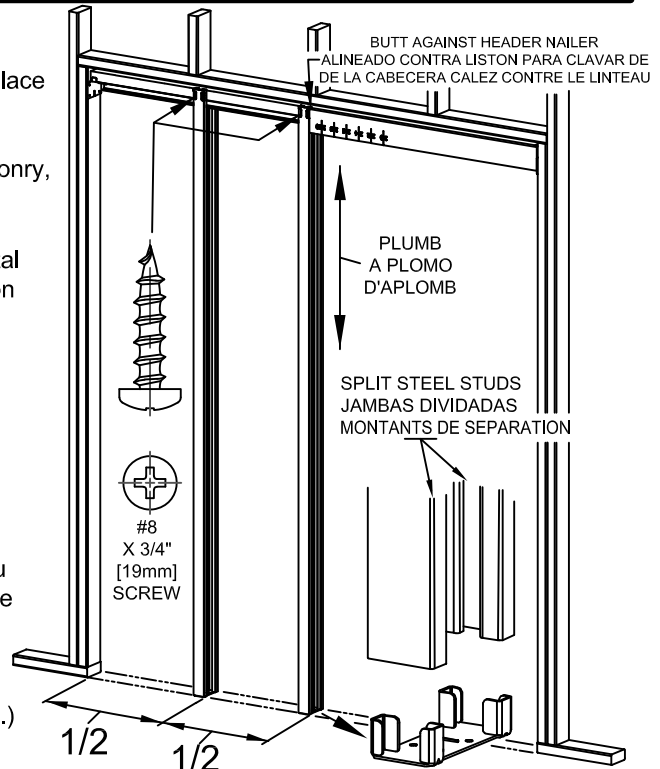

- 6** Apply desired wall material with 1" (25.4mm) X #6 Self drilling drywall screws. Use seven (7) screws per Split Steel Stud.

Coloque el material deseado para la pared con tornillos autoperforantes para tablero de yeso #6 X 25.4mm. Use siete (7) tornillos por jamba dividida.

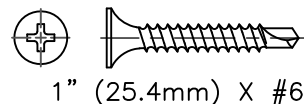

Posez le matériau mural désiré en utilisant des vis auto taraudeuses No. 6 pour cloison sèche de 25.4mm. Utilisez sept (7) vis pour chaque montant séparateur.

- 7** Seal all edges and face of door panel with paint or sealing stain.

Selle todos los bordes y la superficie del entrepaño de la puerta con pintura o barniz para sellar.

Recouvrez de peinture ou de teinture tous les cotés et toutes les faces des panneaux de porte.

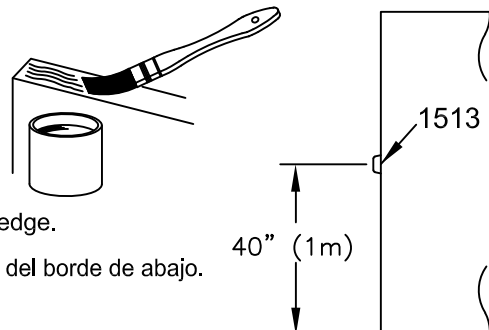

- 8** Fasten 1513 Bumper on back edge of door 40" (1m) from bottom edge.

Coloque el Tope 1513 en el borde de la parte trasera de la puerta y a 1m del borde de abajo.

Fixez le butoir réf. 1513 sur coté de la porte à 1m du bas.

9 FASTEN HANGERS TO DOOR. Fasten door plates to top edge of door as shown, 4" (100mm) from each end, on centerline. Slip hanger wheel assembly into track through space at jamb. Place door into opening and slip the spindle bolt into wheel assembly. (Make sure nylon lock levers are in the "unlocked position.") When both spindles are firmly seated in hanger wheel assembly, push lock levers closed. Adjust door for height and plumb by using spindle-adjusting screws to raise or lower door, then tighten hex locknut to secure setting.

ASEGURE LAS BARRAS DE SUSPENSIÓN A LA PUERTA. Asegure las placas de la puerta al borde superior de la misma como se muestra, a 100mm de cada extremo, en la línea de centros. Deslice la rueda de la barra de suspensión en el carril a través del espacio en el montante. Coloque la puerta en la abertura y deslice el perno de huso en el conjunto de rueda. (Cerciórese de que las palancas de bloqueo de nilón estén en la posición "desbloqueada".) Cuando ambos husos estén firmemente asentados en el conjunto de rueda de la barra de suspensión, cierre las palancas. Ajuste la altura y el nivel de la puerta usando los tornillos de ajuste del huso para subir o bajar la puerta, después apriete la tuerca hexagonal para asegurar el grupo.

ATTACHER LES ROULETTES À LA PORTE. Attacher les plaques de la porte au bord supérieur de celle-ci comme illustré, à 100mm de chaque extrémité, sur la ligne médiane. Glisser l'ensemble galet roulettes dans la glissière à travers l'emplacement se trouvant au niveau du montant. Placer la porte dans l'ouverture et glisser le boulon pivot dans l'ensemble galet. (Il faut s'assurer que les leviers de blocage en nylon sont sur la position "non cweouillée".) Lorsque les deux pivots sont fermement installés dans l'ensemble galet de la glissière, pousser les leviers de blocage vers la position fermée. Régler la hauteur et l'aplomb de la porte à l'aide des vis pivots de réglage afin d'élever ou d'abaisser la porte, puis serrer le contre-écrou hexagonal pour consolider le réglage.

CLEAR ANY DEBRIS FROM TRACK AND WHEELS PRIOR TO HANGING DOOR.

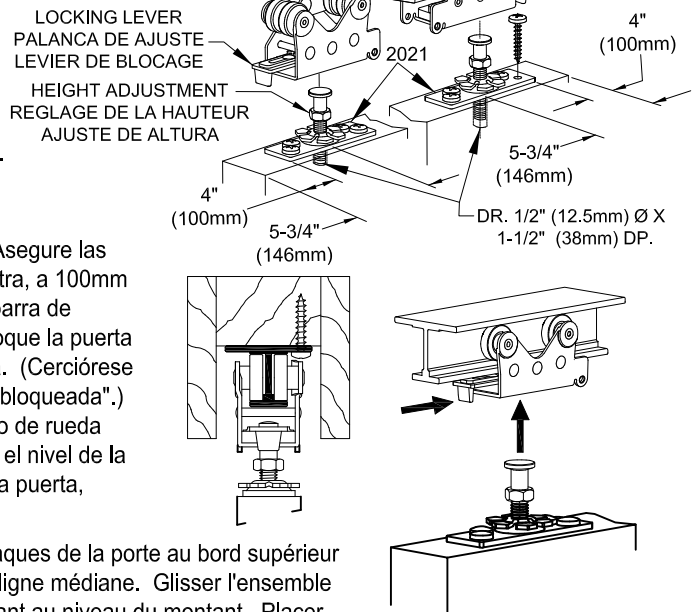

10 Install finished jambs, split header and casing as shown. Fasten one side of split header with screws for future door removal or adjustment.

DO NOT USE JAMBS WITH DADO'S.

Note: Minimum 3/16" (5mm) clearance between jamb and door.

Instale los batientes terminados, el cabecero dividido y el contramarco, como se muestra. Sujete con tornillos un lado del cabecero dividido para su remoción o ajuste futuros. **NO UTILICE BATIENTES CON DADO'S.** Nota: Debe haber una separación mínima de 5mm entre la jamba y la puerta.

Installez les montants finis, le linteau de séparation et le contre-chambranle comme illustré. Serrez un côté du linteau de séparation avec des vis en prévision d'une éventuelle dépose ou d'un ajustement futur.

NE PAS UTILISER DES MONTANTS AVEC DES LAMBRIS D'APPUI.

Nota: Laissez un jeu de 5mm au minimum entre le montant et la porte.

ATTACH FINISH SPLIT JAMB TO STEEL STUD/ PLUMB DOOR WITH JAMB
COLOQUE LA JAMBA DIVIDIDA TERMINADA EN EL PERNO DE ACERO/ NIVELA A PLOMO LA PUERTA CON LA JAMBA
ATTACHER LE MONTANT DE SEPARATION AU SUPPORT EN ACIER/ METTRE D'APLOMB LE MONTANT AVEC LA PORTE

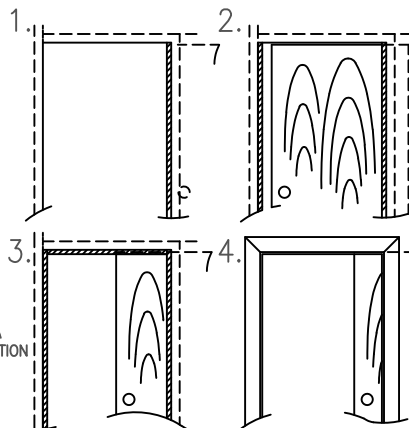

FINISH SPLIT HEADER
CABECERA DIVIDIDA TERMINADA
MONTANT DE SEPARATION FINITION

SHIM AND PLUMB FINISH JAMB WITH DOOR
PONGA CUÑAS Y NIVELA A PLOMO LA JAMBA TERMINADA CON LA PUERTA
CLAIR METTRE D'APLOMB LE MONTANT DE FINITION AVEC LA PORTE

FINISH TRIM
BORDE TERMINADO
BAGUETTE DE FINITION

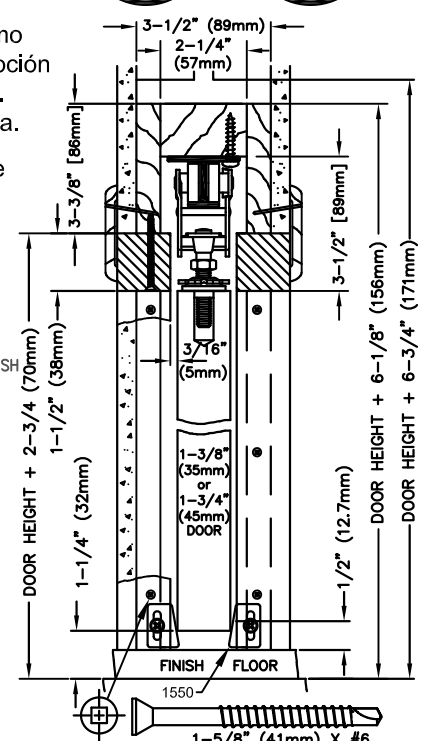

Fasten 1550 Guides on finished split jambs at door bottom so door is held in center of opening.

11 Coloque las guías 1550 en las jambas divididas terminadas, en la parte de abajo de la puerta para que ésta sea sostenida en la mitad de la abertura.

Fixez les guides 1550 sur les montants de séparation au bas de la porte, de sorte que la porte se trouve au centre de l'ouverture.

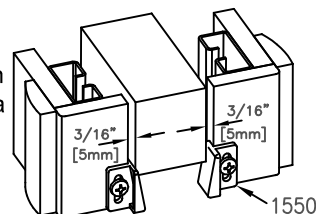

**CUTTING INSTRUCTIONS
POCKET DOOR FRAME HEADER**

2/6" [762mm] and 3/0" [914mm] Pocket Door Frames are marked for cutting to shorter standard door widths.

- 1** Remove Adjustable End Bracket.
Remueva el soporte ajustable del extremo.
Démontez le crochet d'extrémité ajustable.
- 2** At desired door size marking, cut wood header only.
En la marca que corresponde al tamaño deseado de la puerta, corte solamente la madera de la cabecera.
A la marque correspondant à la dimension de porte désirée, découpez seulement le guide en bois.
- 3** Turn header over and cut track 1-3/8" [35mm] shorter than header.
Voltee la cabecera y corte el riel 35mm mas corto que la cabecera.
Retournez le guide et coupez la glissière 35mm plus court que le guide.
- 4** Replace Adjustable End Bracket on new cut end of header.
Reemplace el Soporte Ajustable del Extremo en el nuevo extremo de la cabecera recién cortado.
Remontez le crochet d'extrémité ajustable sur la nouvelle extrémité coupée du guide.
- 5** Turn Header on side and cut Header Trim Board ONLY at proper mark. Remove cut off end and discard.
Voltee la cabecera en un costado y corte solamente la Tabla del Contramarco del Encabezador donde esta la marca apropiada. Remueva el extremo que se corta y bótelo.
Retournez le guide de côté et découpez SEULEMENT la baguette du guide à la marque désirée. Enlevez et jetez l'extrémité coupée.
- 6** Turn Header and cut other side.
Voltee la cabecera y corte el otro costado.
Retournez le guide et découpez l'autre côté.

**INSTRUCCIONES DE CORTE
CABECERA DEL MARCO PARA
PUERTAS CORREDIZAS**

Los marcos de las Puertas Corredizas de 762mm y 914mm estan marcados para ser cortados a anchuras menores la cuales corresponden a puertas estandares.

**INSTRUCTIONS DE COUPE
LINTEAU POUR PORTE ESCAMOTABLE**

Les cadres de porte de 762mm et 914mm sont marquées pour être coupés à des largeurs de portes standard plus courtes.

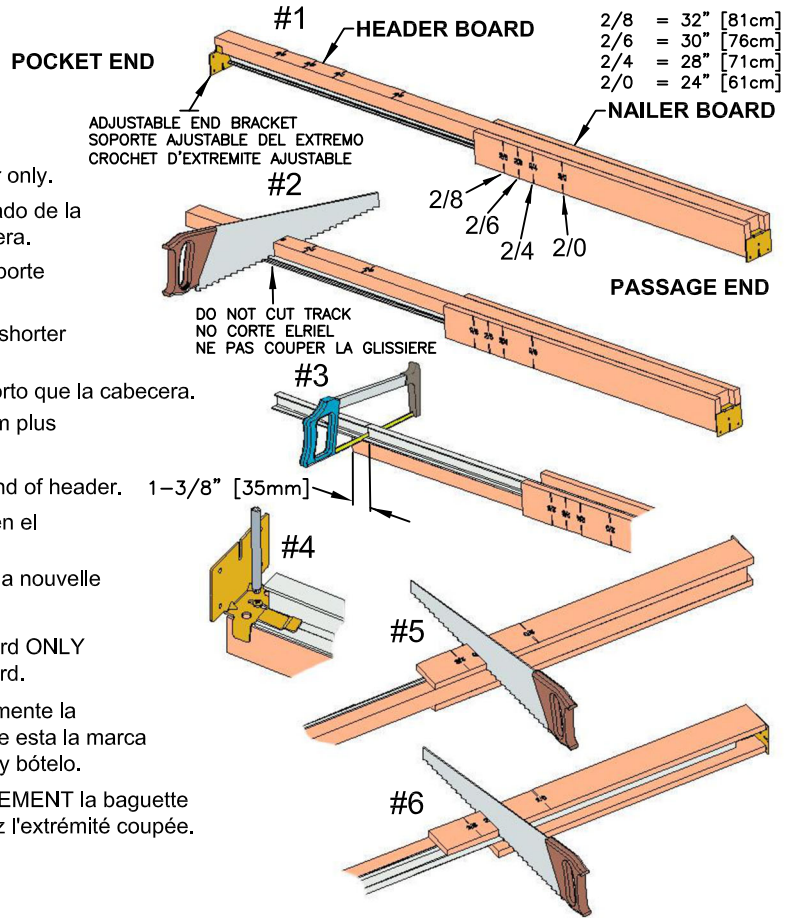

Cutting Instructions for unmarked or non-standard door widths.

1. Measure from "Passage End" of Header Board only (NOT METAL BRACKET) 2 times door width and mark (step #1).
2. Cut Header Board only on mark. (step #2).
3. From Pocket End, cut track 1-3/8" (35mm) shorter then Header Board (step #3).
4. Replace Pocket End Jamb Bracket (step #4).
5. From Passage End, measure Nailer Boards door width plus 3/4" (19mm) mark and cut (steps #5 & #6).

Frame Height Cutdown: Cut from bottom of metal split studs only (end without holes). Cut difference in door height: Ex. 80" frame, 79" door height, cut 1" from bottom of each split stud.

ACCESSORIES

2050
CONVERGING DOOR KIT
CONJUNTO PIEZAS PARA PUERTA CONVERGENTE
ASSEMBLAGE CONVERGENT DE PORTE

30
#30 PULL, CLENCH, JALE
AVAILABLE IN 3 FINISHES
DISPONIBLE EN 3 ACABADOS
DISPONIBLE EN 3 FINITIONS

21
(1-3/8" 35mm)
2-1/8" DIAMETER PULL
TIRADOR DE DIA. DE 54mm
TIRETTE CIRCULAIRE DE 54mm

1521
(1-3/8" 35mm)
PRIVACY LOCK
CERRADURA PRIVADA
SERRURE PRIVÉE

35
1-3/8" X 3" RECTANGULAR PULL
TIRADOR RECTANGULAR DE 35mm X 76mm
TIRETTE RECTANGULAIRE DE 35mm X 76mm

40

150
EDGE PULL
TRADOR DE BORDE
TIRETTE LATÉRALE

1515-PLY
PLYWOOD CLIP SET
JUEGO DE PINZAS PARA MADERA TERCIADA
ENSEMBLE D'ATTACHES DE CONTRAPLAQUÉ



www.johnsonhardware.com

INSTRUCTIONS

CUTTING INSTRUCTIONS POCKET DOOR FRAME HEADER

CUTTING INSTRUCTIONS POCKET DOOR FRAME HEADER

2/6" [762mm] and 3/0" [914mm] Pocket Door Frames are marked for cutting to shorter standard door widths.

INSTRUCCIONES DE CORTE CABECERA DEL MARCO PARA PUERTAS CORREDIZAS

Los marcos de las Puertas Corredizas de 762mm y 914mm estan marcados para ser cortados a anchuras menores la cuales corresponden a puertas estandares.

INSTRUCTIONS DE COUPE LINTEAU POUR PORTE ESCAMOTABLE

Les cadres de porte de 762mm et 914mm sont marquées pour être coupés à des largeurs de portes standard plus courtes.

- 1 Remove Adjustable End Bracket.
Remueva el soporte ajustable del extremo.
Démontez le crochet d'extrémité ajustable.

ADJUSTABLE END BRACKET
SOPORTE AJUSTABLE DEL EXTREMO
CROCHET D'EXTREMITE AJUSTABLE

2/8 = 32" [81cm]
2/6 = 30" [76cm]
2/4 = 28" [71cm]
2/0 = 24" [61cm]

- 2 At desired door size marking, cut wood header only.
En la marca que corresponde al tamaño deseado de la puerta, corte solamente la madera de la cabecera.
A la marque correspondant à la dimension de porte désirée, découpez seulement le guide en bois.

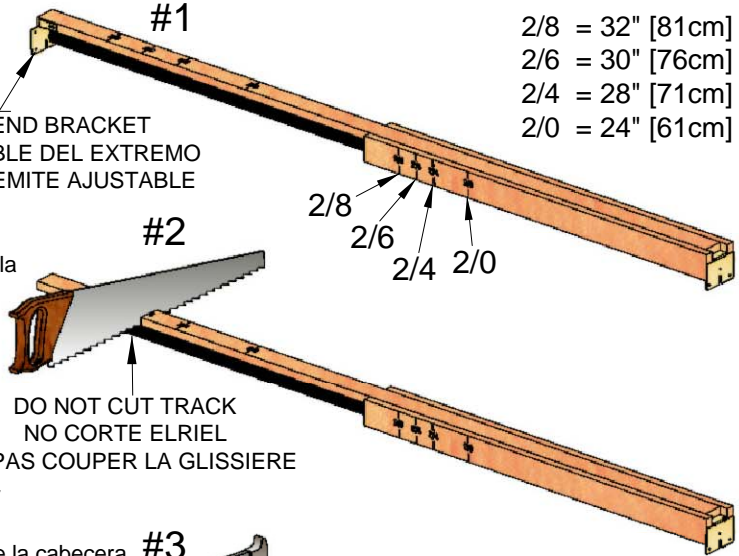

- 3 Turn header over and cut track 1-3/8" [35mm] shorter than header.
Voltee la cabecera y corte el riel 35mm mas corto que la cabecera.
Retournez le guide et coupez la glissière 35mm plus court que le guide.

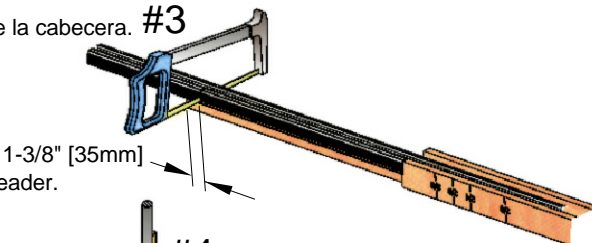

- 4 Replace Adjustable End Bracket on new cut end of header.
Reemplace el Soporte Ajustable del Extremo en el nuevo extremo de la cabecera recién cortado.
Remontez le crochet d'extrémité ajustable sur la nouvelle extrémité coupée du guide.

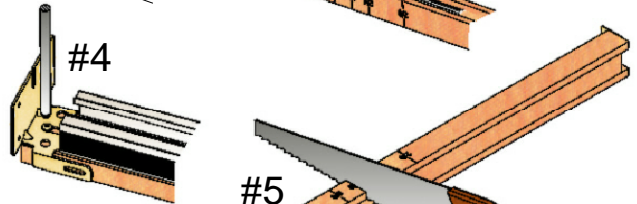

- 5 Turn Header on side and cut Header Trim Board ONLY at proper mark. Remove cut off end and discard.
Voltee la cabecera en un costado y corte solamente la Tabla del Contramarco del Encabezador donde esta la marca apropiada. Remueva el extremo que se corta y bótelo.

Retournez le guide de coté et découpez SEULEMENT la baguette du guide à la marque désirée. Enlevez et jetez l'extrémité coupée.

- 6 Turn Header and cut other side.
Voltee la cabecera y corte el otro costado.
Retournez le guide et découpez l'autre coté.

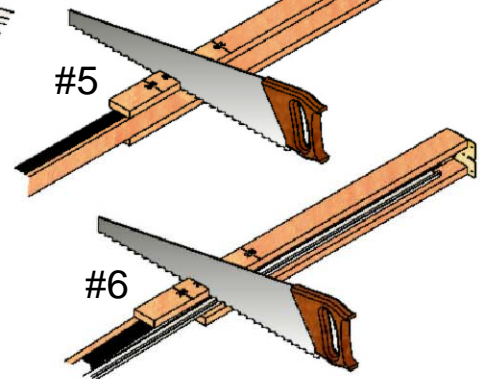

Cutting header for other than standard door width:
Measure door width and multiply by 2. Add 1" (25mm).
Mark header and cut (Step #2). Cut track (Step #3).
Measure door width. Add 1" (25mm). Mark header
Trim board and cut (Step #5 & #6).

Para cortar la cabecera para puertas que no sean de un ancho estandar: Mida el ancho de la puerta y multipliquelo por 2. Súmele 25mm. Marque la cabecera y córtelo (Paso #2). Corte el riel (Paso #3). Mida el ancho de la puerta. Súmele 25mm. Marque la guía de la tabla del contramarco de la cabecera y córtelo (pasos #5 & #6).

Découpage de la porte à une dimension non standard: Mesurez la largeur de la porte et multipliez par 2. Ajoutez 25mm. Marquez le guide et découpez. (étape #2). Découpez la glissière (étape #3). Mesurez la largeur de la porte. Ajoutez 25mm. Marquez la baguette du guide et découpez (étape #5 & #6).

INSTRUCTIONS

Cutting Instructions for unmarked frames or non standard door widths

1 Mark Header and Side Nailers for door size.

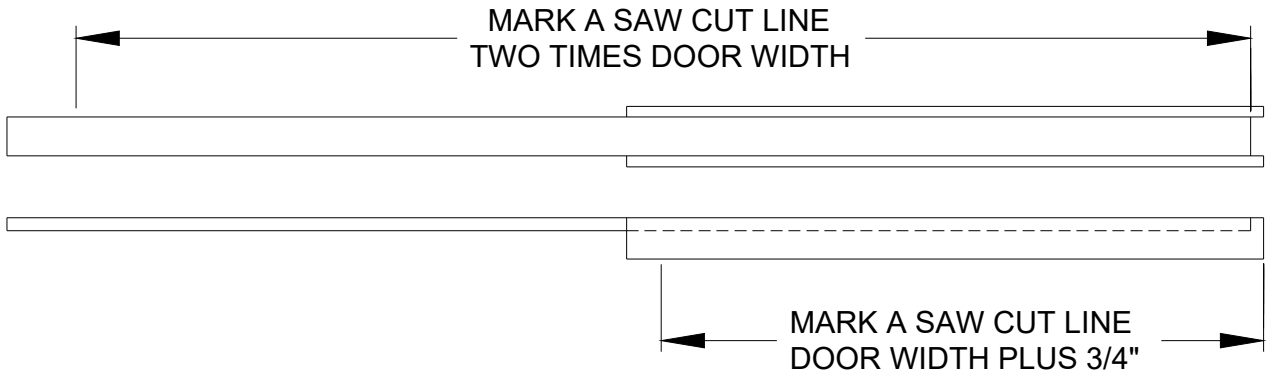

2 Remove Adjustable End Bracket.

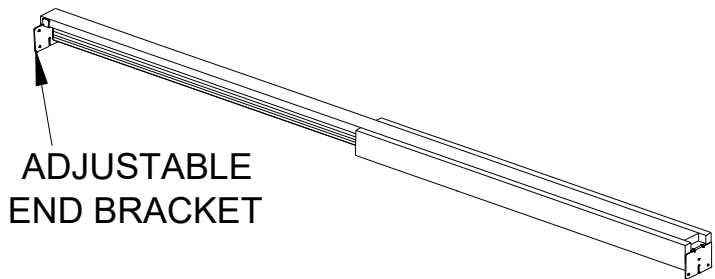

5 Replace Adjustable End Bracket on new cut end of header.

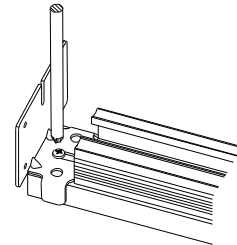

3 Cut through WOOD part of header only at mark.

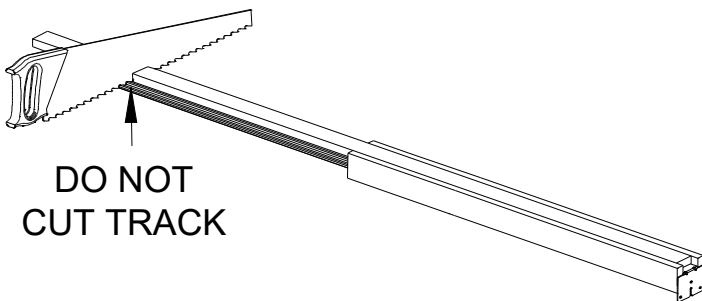

6 Turn Header on side and cut Side Nailer Trim Board ONLY at mark. Remove cut off end and discard.

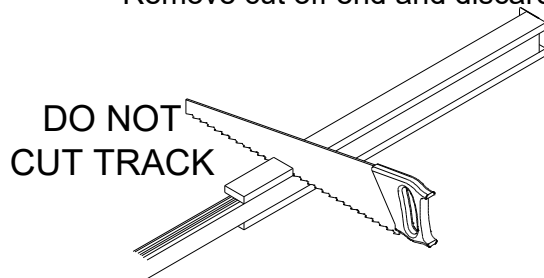

4 Turn Header over and cut Track 1-3/8" shorter than wood Header.

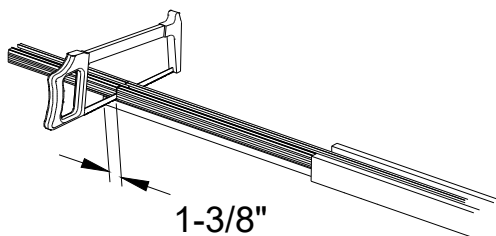

7 Repeat step #6 on the other Side Nailer Trim Board.

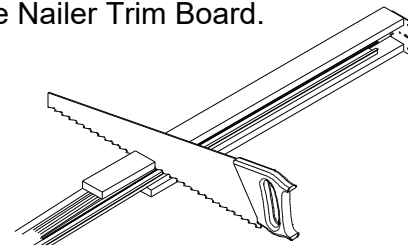



www.johnsonhardware.com

INSTRUCTIONS

SPECIAL APPLICATIONS

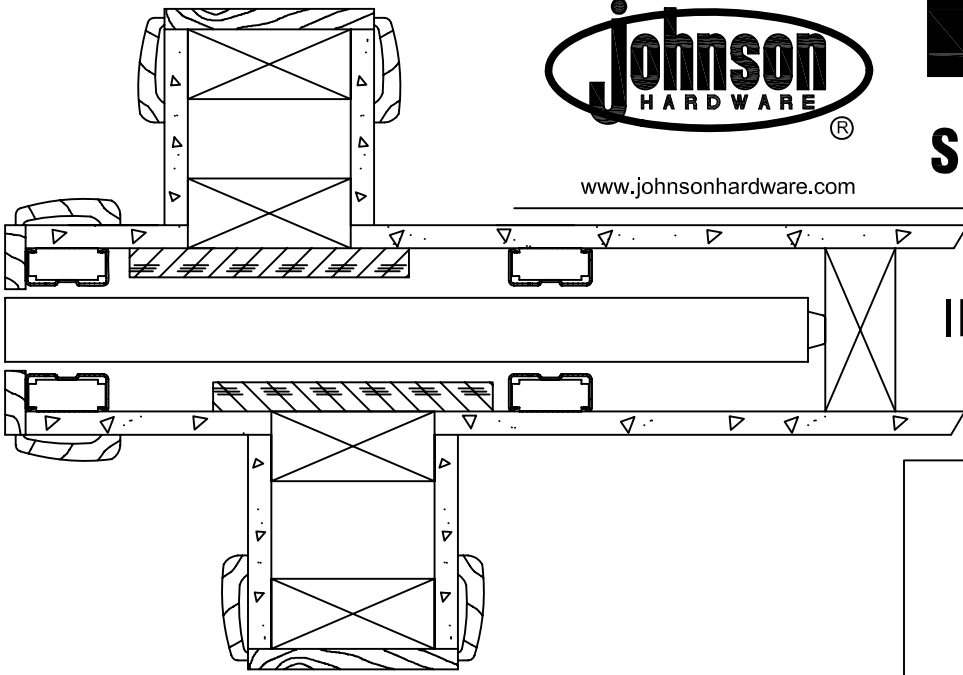

INTERSECTING WALLS

DOOR SWEEP

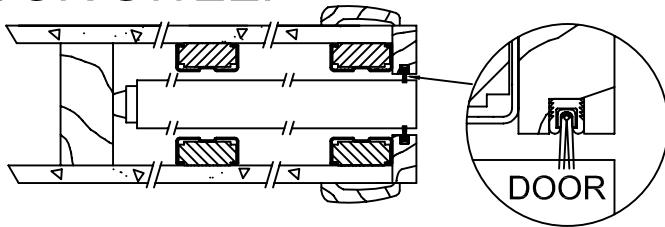

● PEMKO 5025_p

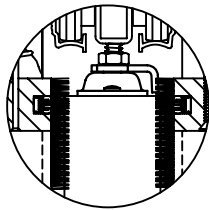

3/16" (5mm)

3/4" (19mm)

DOOR HEIGHT + 4-1/2" (114mm)

1/8" (3.2mm)

No. 6 x 5/8" PHSMS, Phillips (Factory Provided)

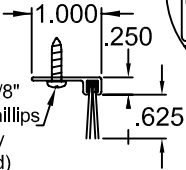

● PEMKO 90062_P

TRANSOM

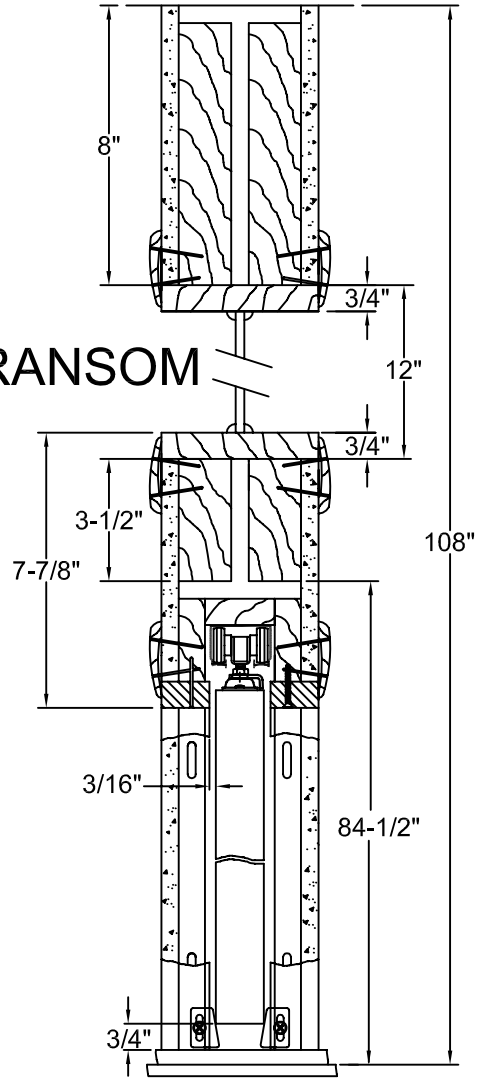

BI - PARTING POCKET DOOR

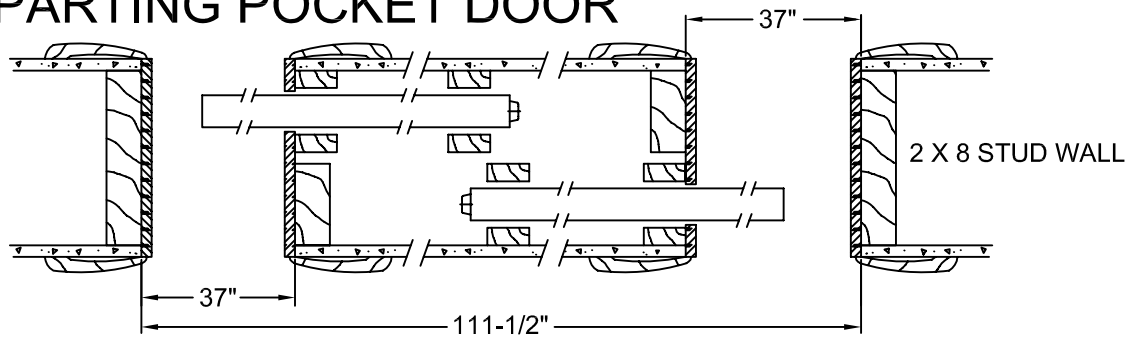

INSTRUCTIONS

2066 SINGLE DIRECTION SOFT-CLOSE KIT FOR 200 SERIES POCKET DOOR HARDWARE

2020 Door Hanger
NOT INCLUDED

2066 Soft-Close Kit

200 Single Direction Soft Operation

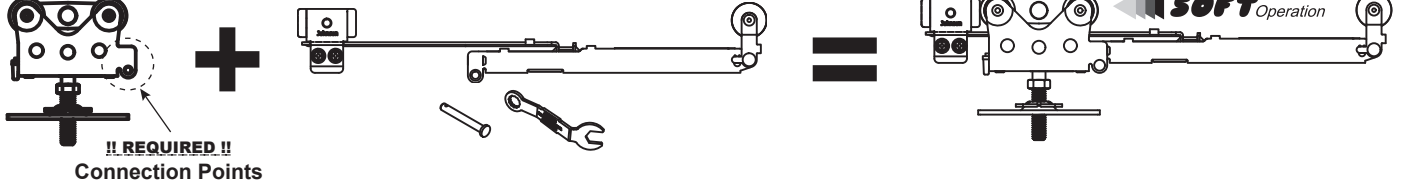

Installation Requirements

330lbs. (150kg) max. per door

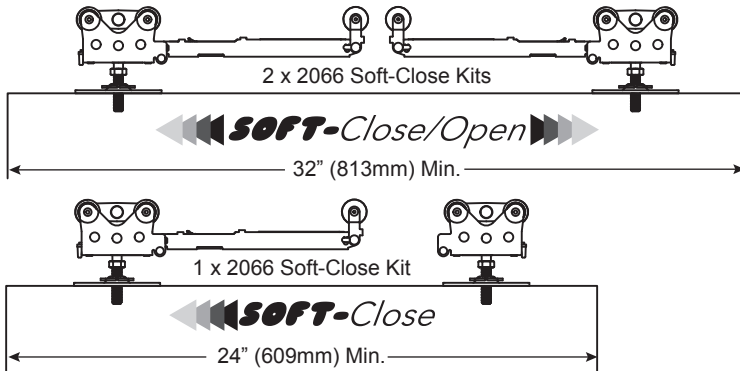

Included Components

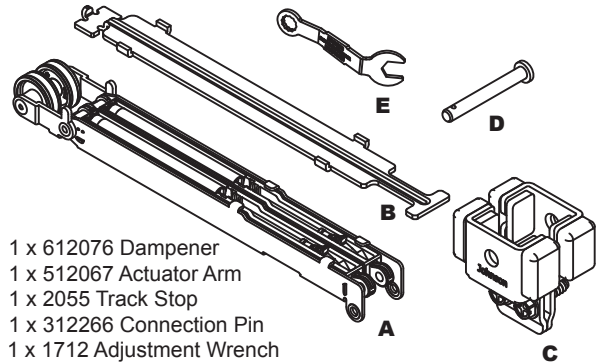

- (A) 1 x 612076 Dampener
- (B) 1 x 512067 Actuator Arm
- (C) 1 x 2055 Track Stop
- (D) 1 x 312266 Connection Pin
- (E) 1 x 1712 Adjustment Wrench

Soft-Close Operation (door soft operates against strike jamb):

1. If door is already installed, disconnect 2020 hangers from 2021 door plates and remove door.
2. Remove 2020 hanger closest to strike jamb from track.
3. Set dampener triggers to engaged position **BEFORE** installing into track. **FAILURE TO FOLLOW THIS STEP CAN RESULT IN COMPONENT DAMAGE.**
4. Install dampener **A** into track(1), dampener triggers towards strike jamb then slide dampener towards center of track(2).
5. Reinstall 2020 hanger into track with connection points towards dampener **A**.
6. Connect 2020 hanger to dampener **A** with connection pin **D**.
7. Insert actuator arm **B** into track stop **C**.
8. Insert track stop **C** with actuator arm **B** into track and position 2-7/16" (62mm) from strike jamb. Tighten track stop **C** to track with adjustment wrench **E**.
9. Attach 2021 door plate 4" (102mm) from edge of door to edge of plate.
10. Reconnect 2020 Hanger to 2021 door plate. Installation complete.
11. Test operation.. Slowly close door, ensuring door contacts strike jamb. If not, slide door away and loosen track stop **C** screws and reposition until door contacts strike jamb. Once confirmed, begin using door normally.

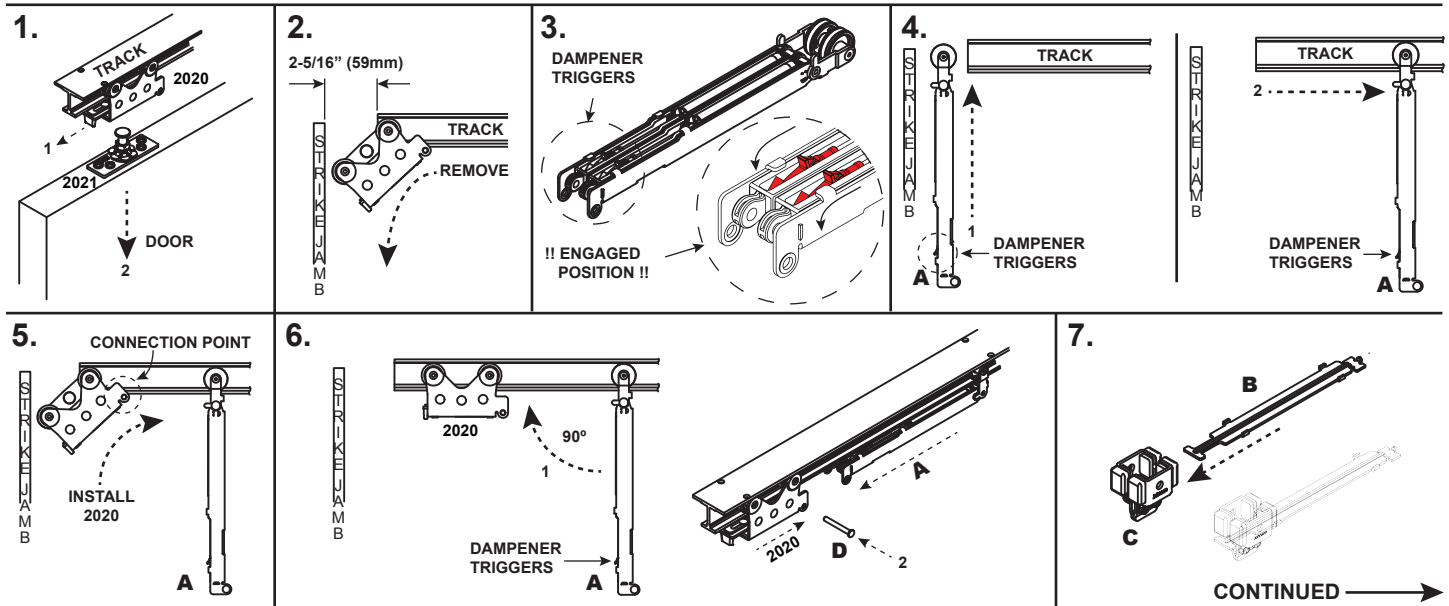

CONTINUED →

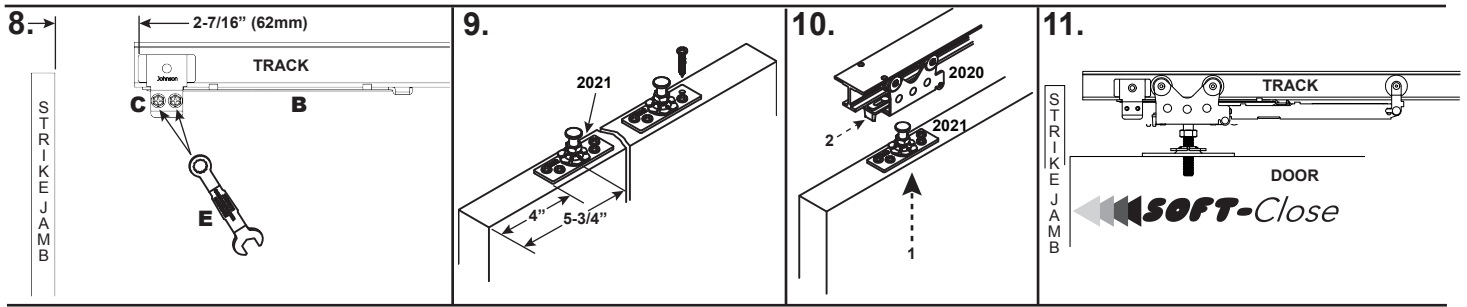

Soft Open Operation (door soft operates into pocket):

Existing Installation (skip steps 1 - 5 if new installation)

1. Disconnect 2020 door hangers from 2021 door plates(1) and remove door from pocket(2).
2. Remove 2020 hanger from track.
3. Measure door width and height
4. From pocket opening back, measure door width minus 2" (51mm), make vertical mark. From this mark measure 8" towards opening and make vertical mark. From finished floor, measure up door height minus 2" (51mm) and make horizontal mark, from this mark measure 8" down and make horizontal mark.
5. Cut square in wall to access track.

New Installation

6. Insert actuator arm **B** into track stop **C**.
7. Insert track stop **C** with actuator arm **B** into track and position 2-7/8" (73mm) + FINISH JAMB THICKNESS from rough stud then tighten track stop **C** to track with adjustment wrench **E**.
8. Reinstall 2020 hanger
9. Set dampener triggers to engaged position **BEFORE** installing into track. **FAILURE TO FOLLOW THIS STEP CAN RESULT IN COMPONENT DAMAGE.**
10. Insert dampener **A** into track(1), dampener triggers away from strike jamb and slide towards 2020 hanger(2).
11. Connect to 2020 hanger to dampener **A** with connection pin **D**.
12. Attach 2021 Door Plate 4" (102mm) from edge of door.
13. Connect 2020 hanger to 2021 door plate. Installation complete, test operation.

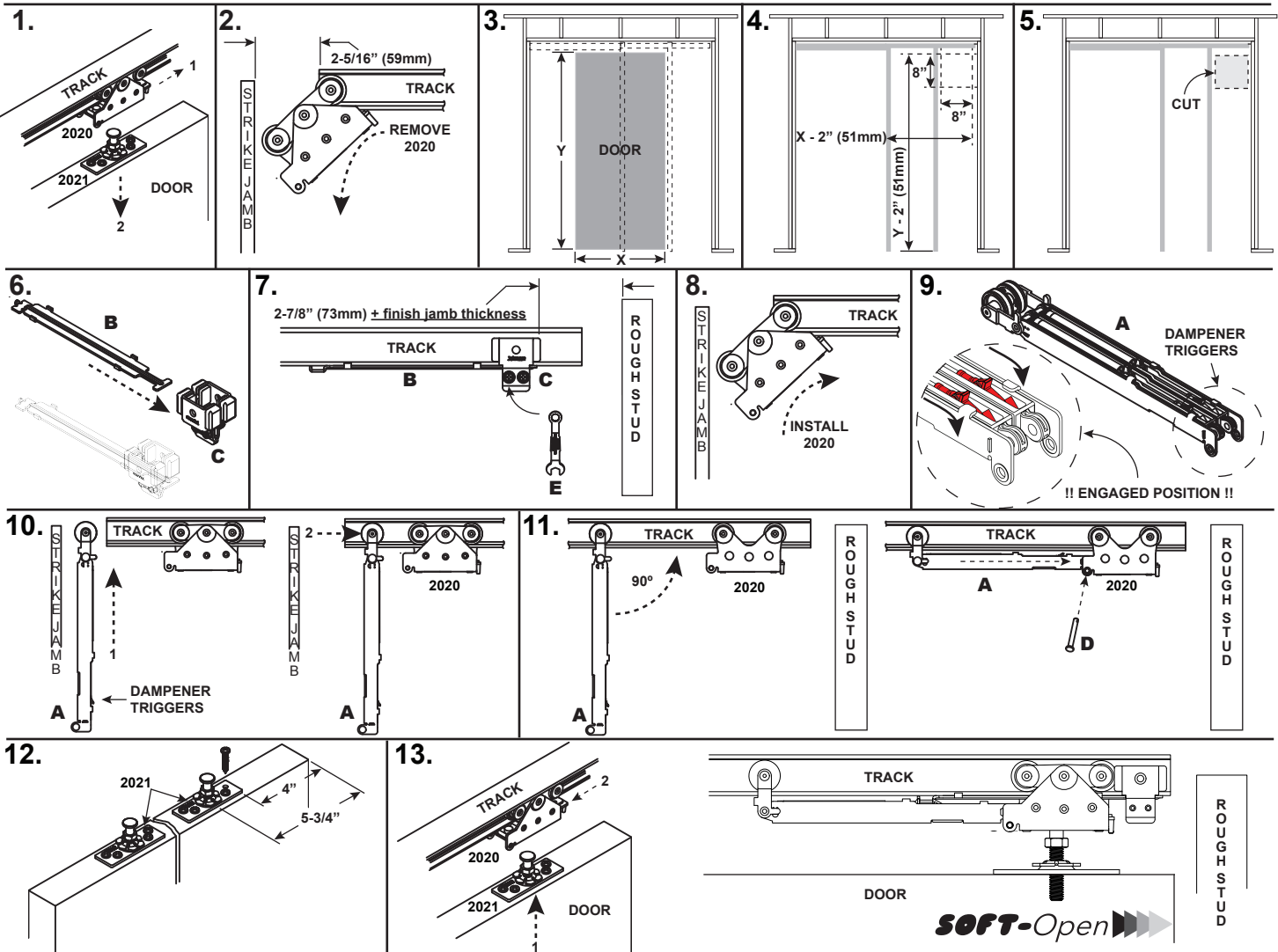

INSTRUCTIONS

2066 SINGLE DIRECTION SOFT-CLOSE KIT FOR 200 SERIES SLIDING/WALL MOUNT DOOR HARDWARE

2020 Door Hanger
NOT INCLUDED

2066 Soft-Close Kit

200 Single Direction Soft Operation

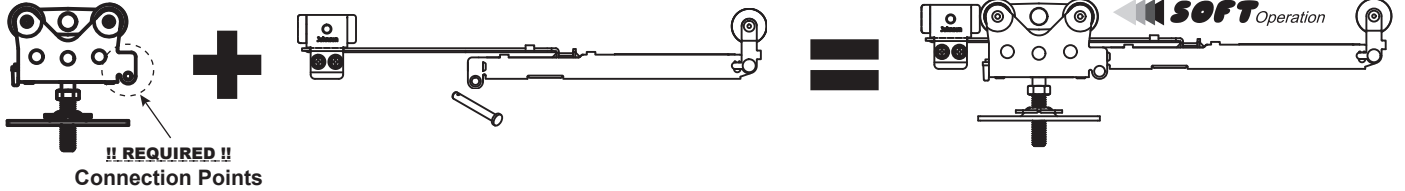

Installation Requirements

330lbs. (150kg) max. per door

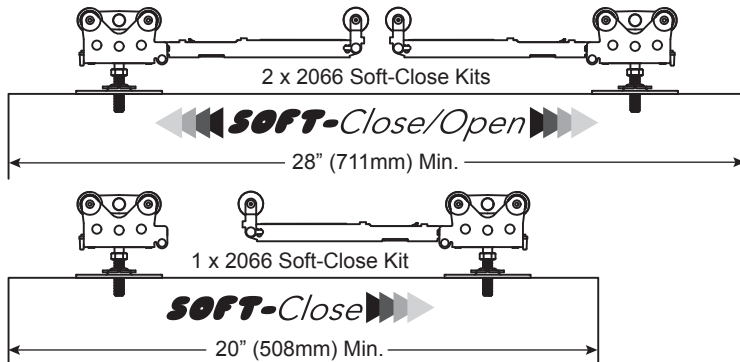

Included Components

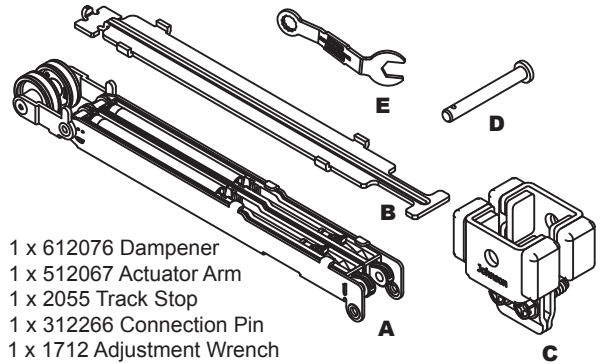

Single direction Soft-Operation **←←SOFT-Operation OR SOFT-Operation→→** (door soft operates in a single direction):

- If track is already installed, disconnect 2020 hangers from 2021 door plates(1) and remove door(2).
- Remove 2020 hanger from track. If 2020 hangers cannot be removed through end of track, take track down.
- Set dampener triggers to engaged position **BEFORE** installing into track. **FAILURE TO FOLLOW THIS STEP CAN RESULT IN COMPONENT DAMAGE.**
- Install dampener **A** into track(1), dampener triggers towards finish jamb in desired soft operation direction then slide dampener towards center of track(2).
- Reinstall 2020 hangers into track with connection points towards dampener **A**.
- Connect 2020 hangers to dampeners **A** with connection pins **D**.
- Insert actuator arms **B** into track stops **C**.
- Insert track stops **C** with actuator arms **B** into track and position 3/16" (4.8mm) from finish jamb. Tighten track stops **C** to track with adjustment wrench **E**.
- Attach 2021 door plate 1-3/4" (44mm) from edge of door to edge of plate.
- Reconnect 2020 Hanger to 2021 door plate. Installation complete.
- Test operation. Slowly close door, ensuring door contacts strike jamb. If not, slide door away and loosen track stop **C** screws and reposition until door contacts strike jamb. Once confirmed, begin using door normally.

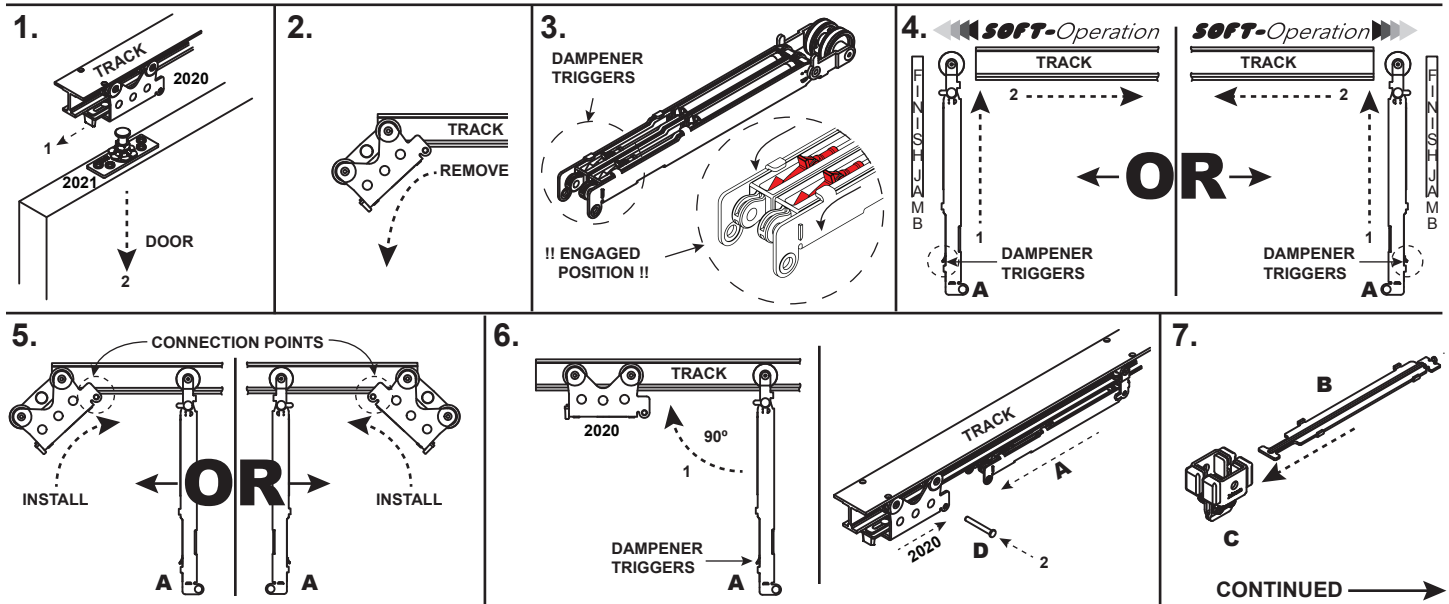

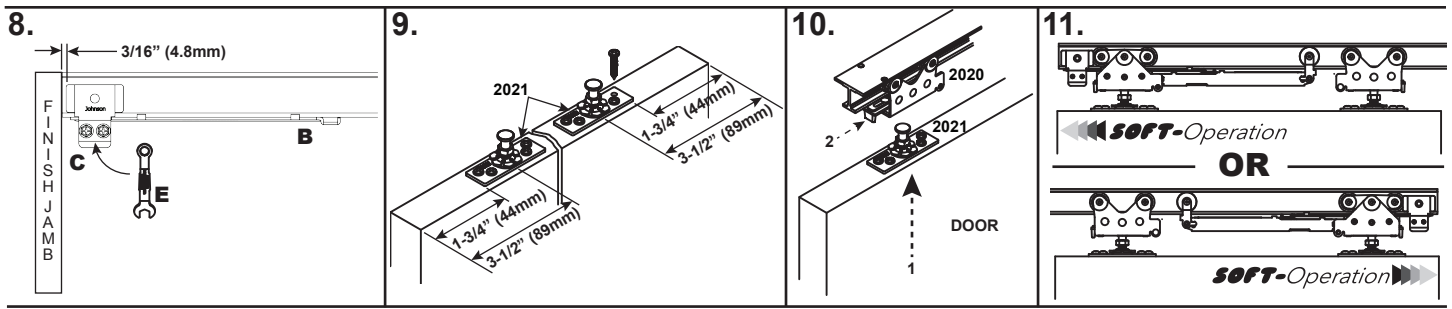

Bidirectional Soft Operation ◀◀ *SOFT-Operation* ▶▶ (door soft operates in both directions):

1. If door is already installed, disconnect 2020 door hangers from 2021 door plates and remove door.
2. Remove 2020 hangers from track. If 2020 hangers cannot be removed through end of track, take track down.
3. Set dampener triggers to engaged position **BEFORE** installing into track. **FAILURE TO FOLLOW THIS STEP CAN RESULT IN COMPONENT DAMAGE.**
4. Insert two dampeners **A** into track(1), dampener triggers away from track center then slide both dampeners towards center of track(2).
5. Reinstall 2021 hanger into track, connection points towards dampener **A**, reinstall track if necessary.
6. Connect 2020 hangers to dampeners **A** with connection pin **D**.
7. Insert actuator arm **B** into track stop **C**.
8. Insert track stop **C** with actuator arm **B** into track and position **3/16" (4.8mm)** from finish jamb then tighten track stop **C** to track with adjustment wrench **E**.
9. Attach 2021 Door Plate 1-3/4" (44mm) from edge of door.
10. Connect 2020 hanger to 2021 door plate.
11. Installation complete, test operation.

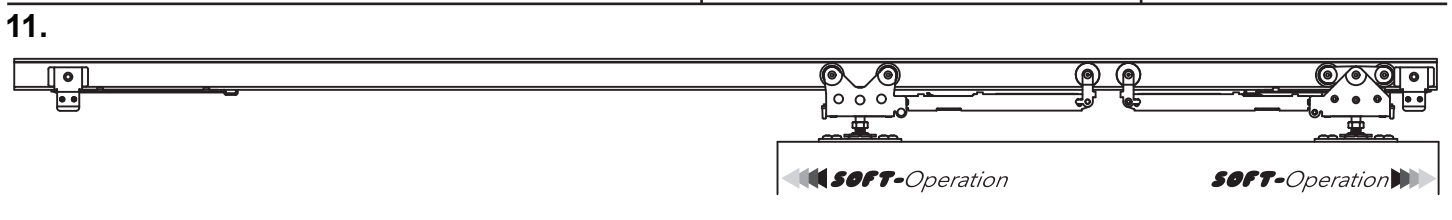
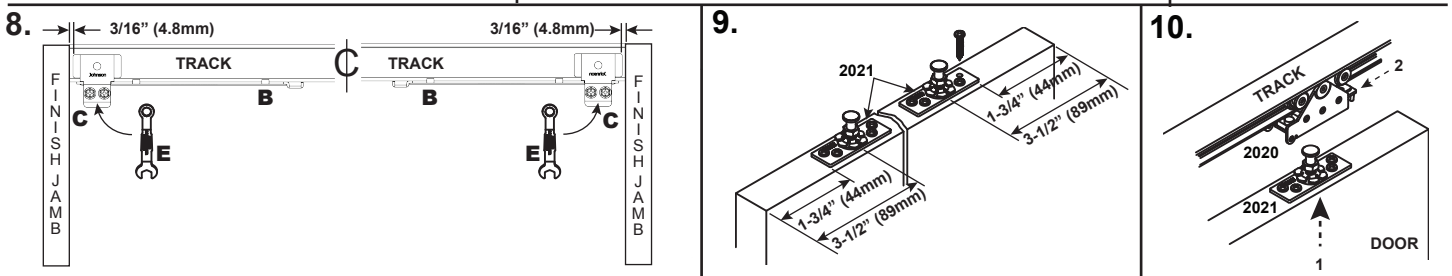
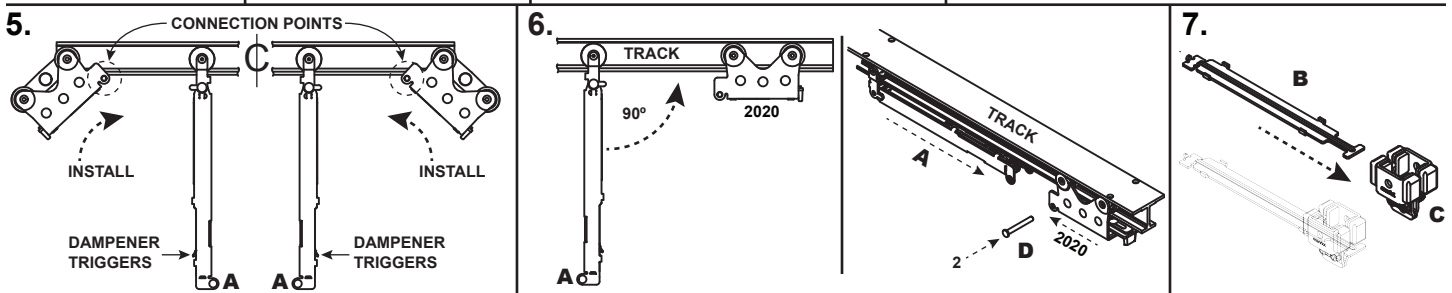
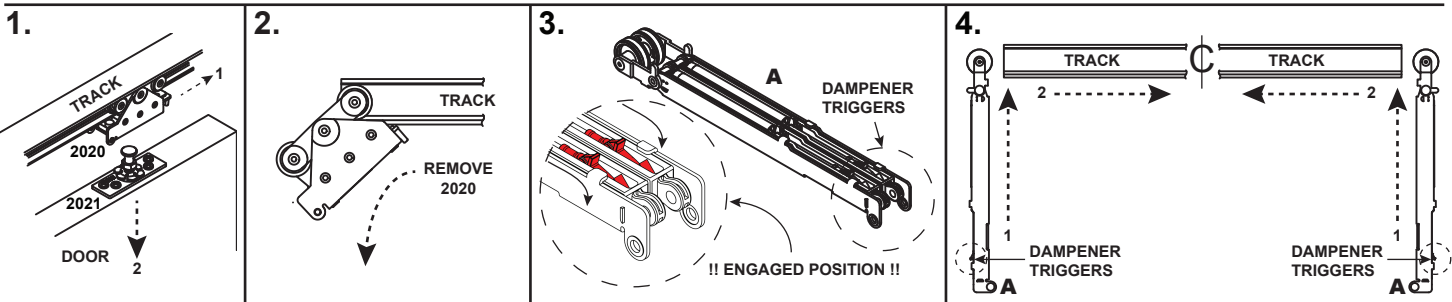

INSTRUCTIONS

2041 PDF BOTTOM GUIDE SET

FOR USE WITH JOHNSON
2000, 2060, 1500, 1560, 2511
POCKET DOOR FRAMES

1 ROUT 5/16" (8mm) X 1" (25mm) groove in bottom of Door.

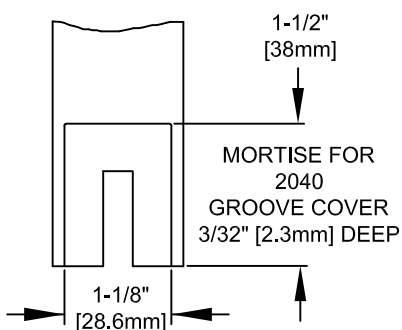
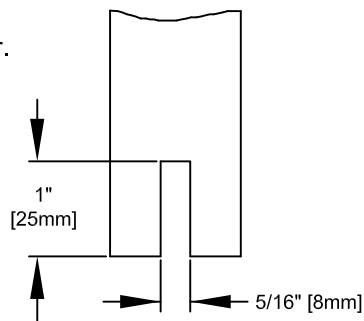

2 MORTISE end of Door's front edge for 2040 Groove Cover. 1-1/8" (28.6mm) wide X 1-1/2" (38mm) high X 3/32" (2.3mm) deep.

3 ATTACH 2041 Guide to floor bracket located at edge of front pocket opening. Use tall guide if Frame Floor Bracket is attached to the sub-floor or the short guide when it is attached to finished floor.

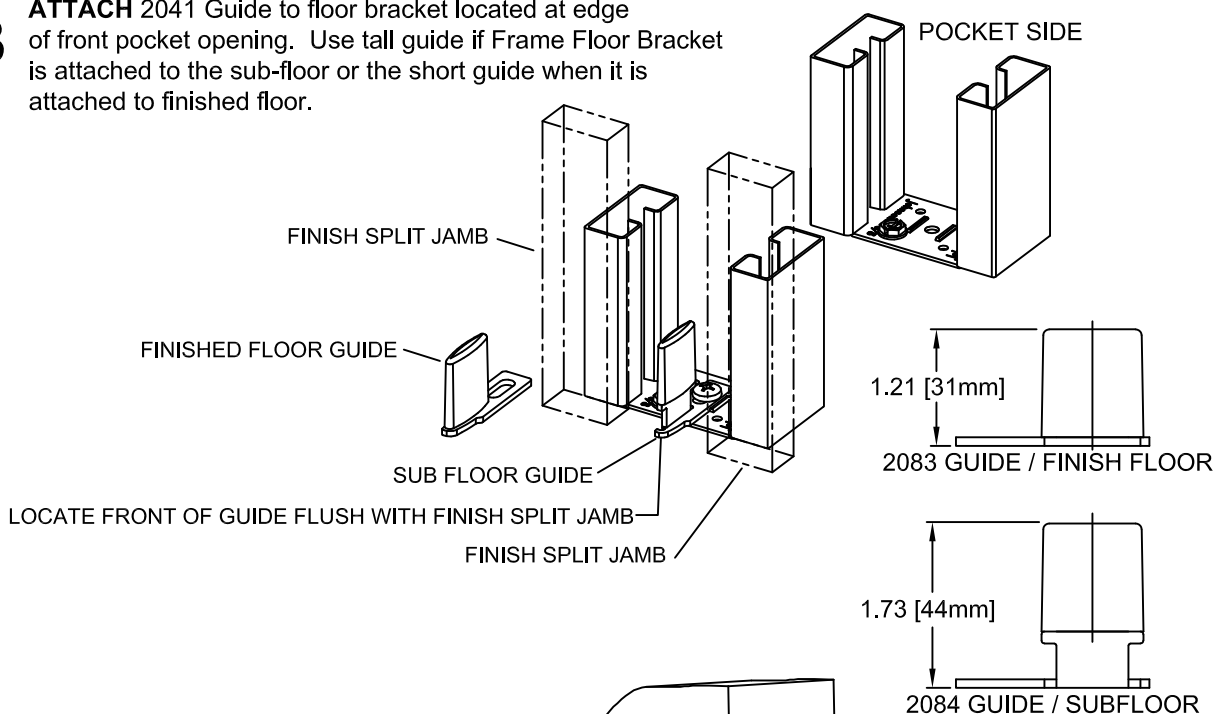

4 ATTACH 2040 Rout Groove Cover in mortise area.

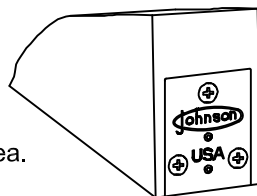

PASSAGE SIDE VIEW



INSTRUCTIONS

For 1/2" (12.5mm)
Tempered Glass Door Panel
Maximum Door Weight 400 lbs. (182kg.)

www.johnsonhardware.com

200 POCKET DOOR GLASS DOOR HARDWARE

- Prepare opening to dimensions as shown on 2000 & 2060 instruction's.
- Insert 2020 Hanger wheels into track with locking levers facing ends of track.

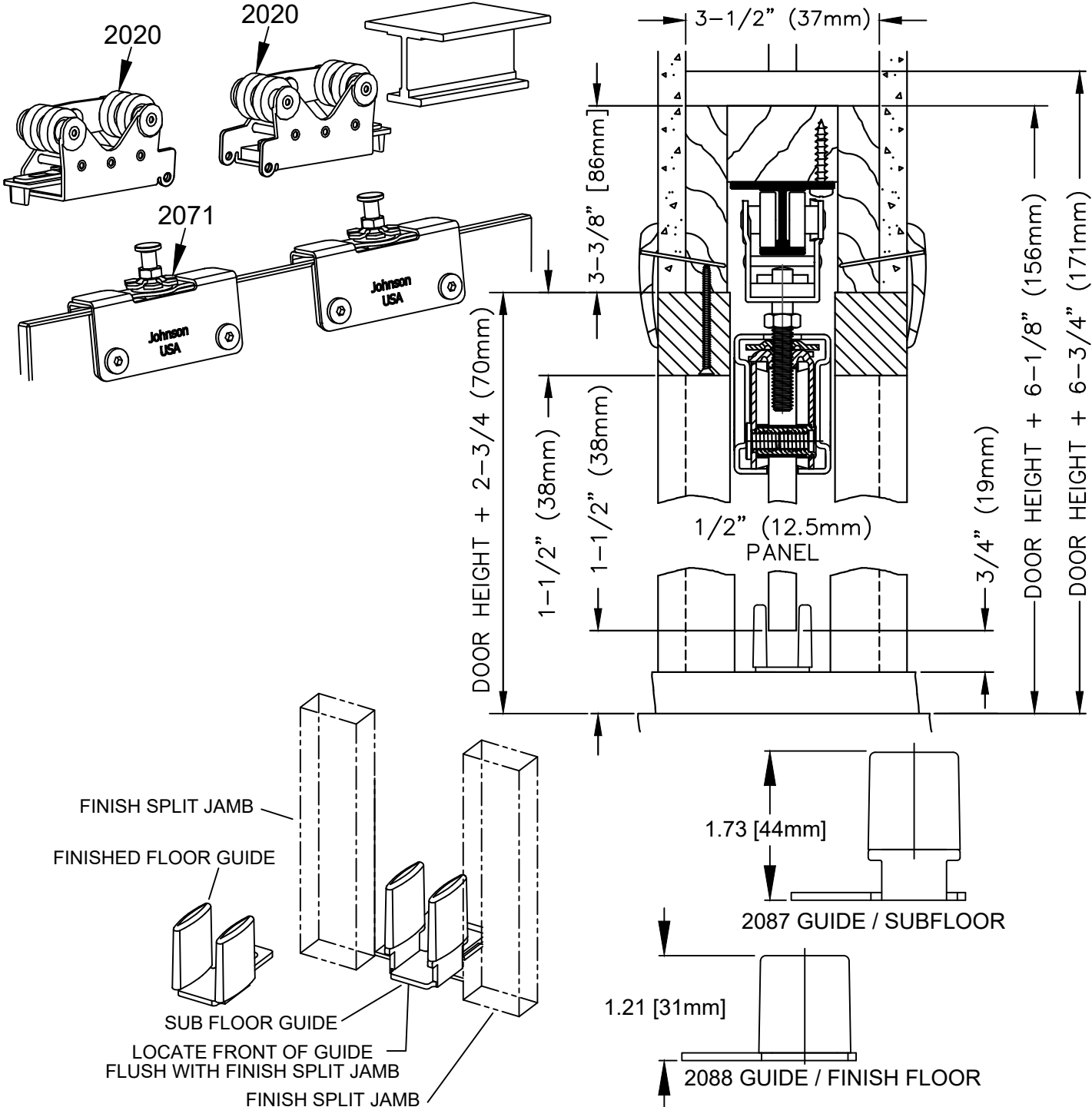

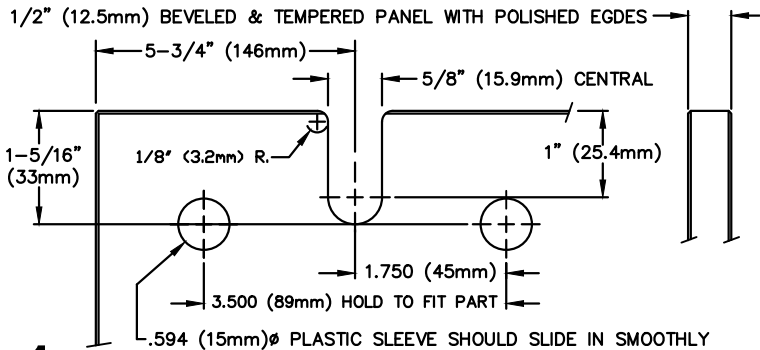

1 HAVE GLASS beveled, drilled and tempered per illustration.

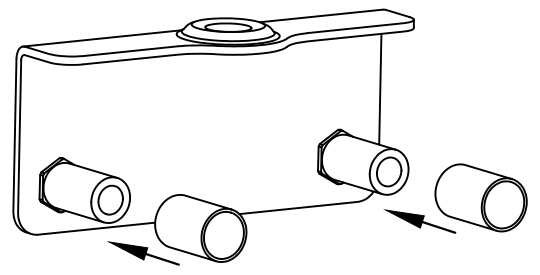

2 SLIDE PLASTIC SLEEVES over hanger post.

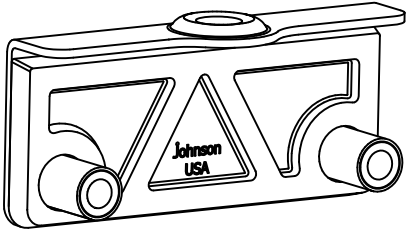

3 INSERT RUBBER PAD over post with smooth side facing metal plate.

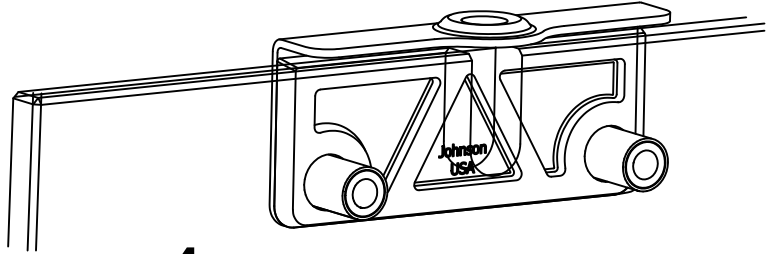

4 INSERT DOOR PLATE into holes drilled in door.

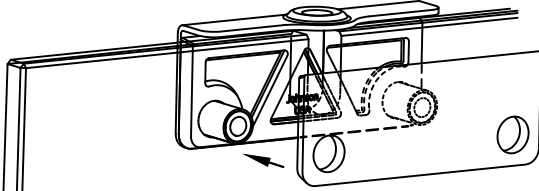

5 INSERT SECOND RUBBER pad on other side of glass, smooth side facing away from glass.

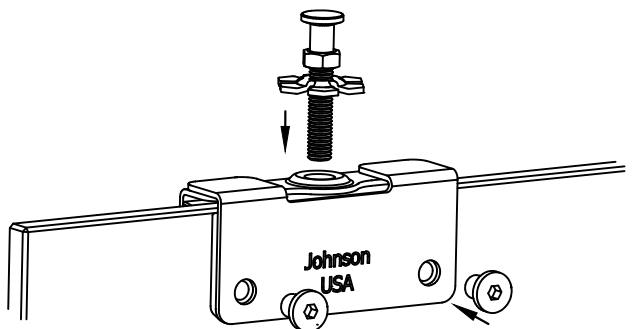

6 LAY OTHER HANGER PLATE against pad and thread 3/8" screws into metal post. Thread hex slotted Locknut onto adjusting bolt, then thread adjusting bolt into door plate.

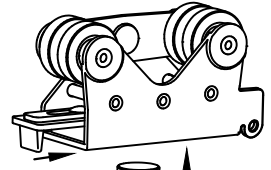

CLEAR ANY DEBRIS FROM TRACK AND WHEELS PRIOR TO HANGING DOOR.

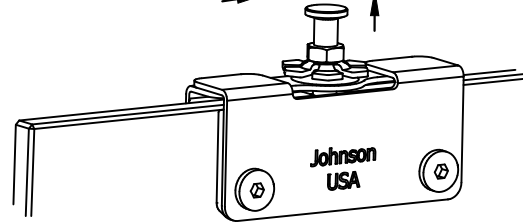

7 HANG GLASS DOOR. Adjust Hanger then tighten locknut.

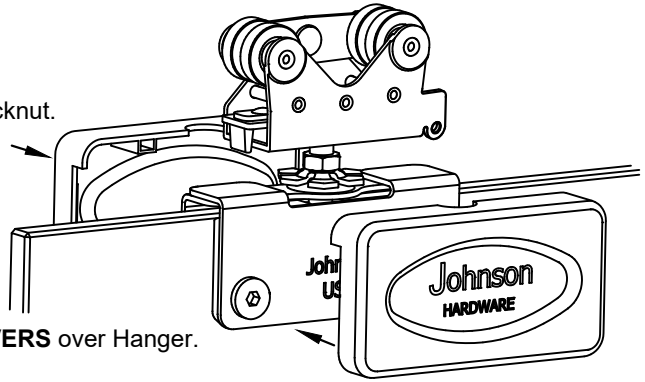

8 SNAP HANGER COVERS over Hanger.



INSTRUCTIONS

HANDICAPPED ACCESSIBLE OPENING

www.johnsonhardware.com

- The Pocket Door Frame is the perfect solution to achieve handicapped accessible opening in the interior of any home or commercial establishment.
- The Pocket Door does not need to swing in or out of an opening. The swinging of a door requires forward or backward movement of a person using a walker or a wheel chair.
- All the Pocket Door requires is the movement of the door left or right. The handicapped person can support themselves in the walker or wheel chair and move their arm across the front of their body.
- A swinging door requires a person to move backward or forward to follow the movement of the door. This requires the handicapped person to not only operate the door with one hand but move the walker or wheel chair with the other. This may be just an irritant to someone in a wheel chair, but it could be dangerous for someone using a walker.

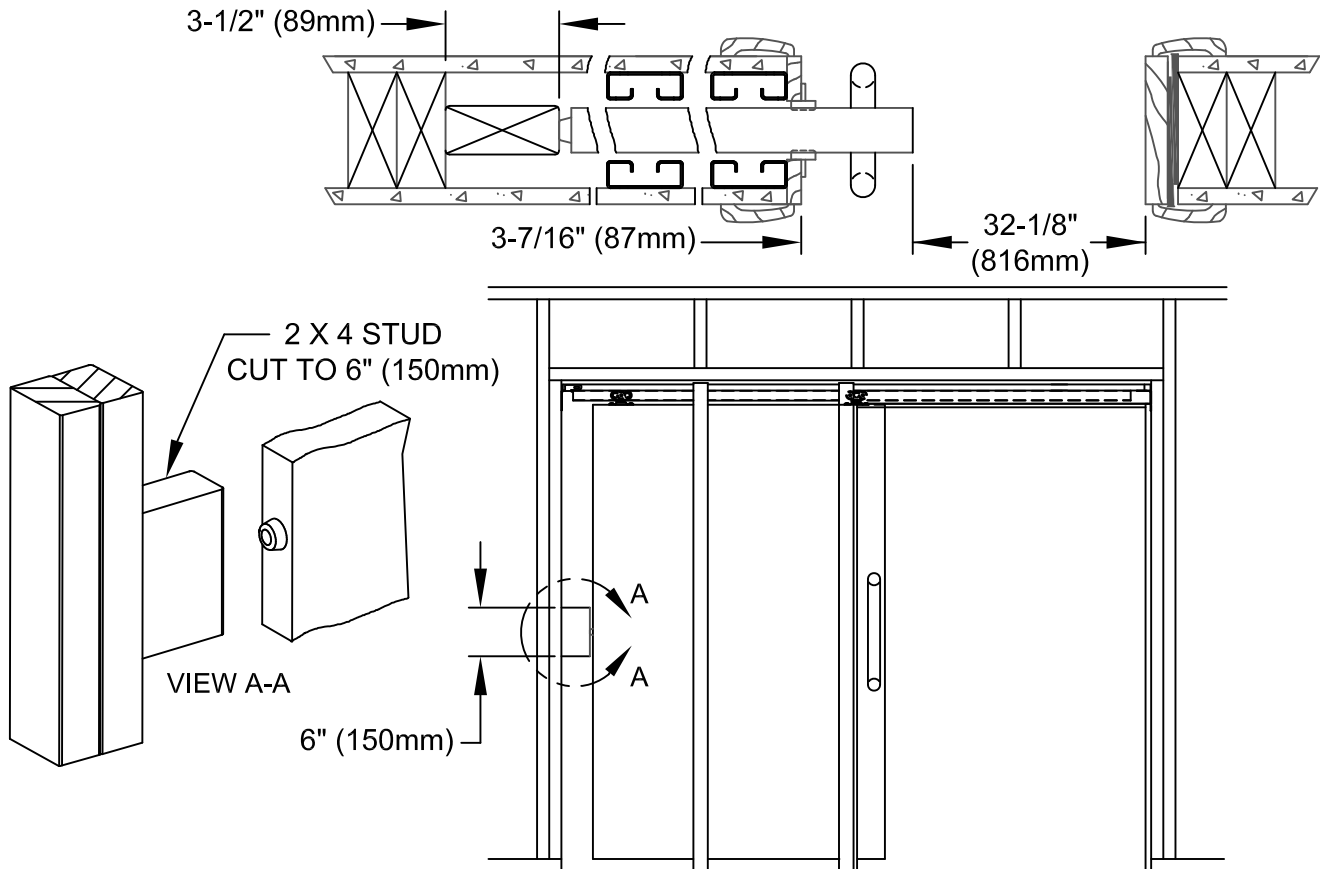

1500 SERIES FRAME WITH HANDICAP PULLS

To meet ADA 4.13.9 Door Hardware and 4.13.11 Door Opening Force requirements, the handicap pulls need to always be exposed in the opening and the maximum force to move the door is 5lbs. (2.3kg). To achieve this, start with a 153068HD Pocket Door Frame, with #1125 ball bearing hangers, and a 36" (914mm) door.

(Can also use the 2000 for 2 X 4 stud walls, 2 X 6 stud walls use the 2060 or 1560)

1. Make the rough opening according to the instructions for a 36" (914mm) door.
2. Before drywalling the opening, put a 2 X 4 by 6" (150mm) piece of wood on the pocket end rough stud at the point the rubber bumper, which is attached to the door, would hit the rough stud.
3. Apply drywall
4. Finish opening according to instruction sheet.
5. After opening has finished trim on it, the door will protrude from the pocket approximately 3-7/16" (87mm). Attach large "U" shaped handicap pull to door.
6. The clear opening will be approximately 32-1/8" (816mm).
7. If you would like a larger amount of the door protruding into the opening or more clear opening use a larger frame and door.
Example: 42" (1066mm) door and 5-7/16" (138mm) of door protruding would equal a clear opening of 36-1/8" (916mm).

CONVERGING CORNER POCKET

USE APPROPRIATE SIZE LAG BOLT TO SECURE THRU JOHNSON HEADERS
TO ROUGH POCKET DOOR OPENING HEADERS

USE TWO #12 PAN HEAD SCREW TO FASTEN
BRACKET TO JOHNSON POCKET DOOR HEADER

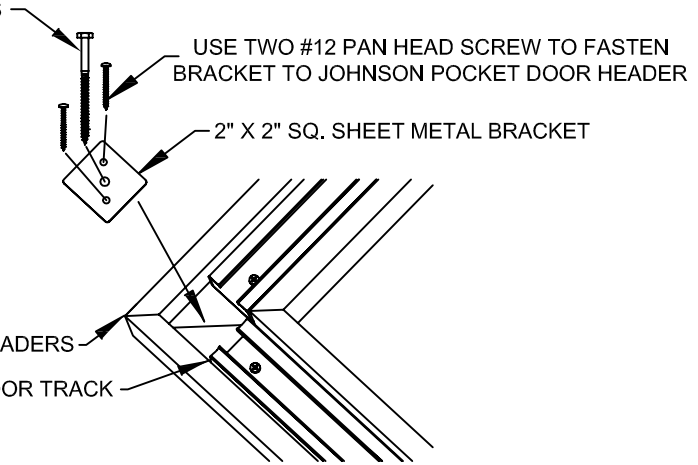
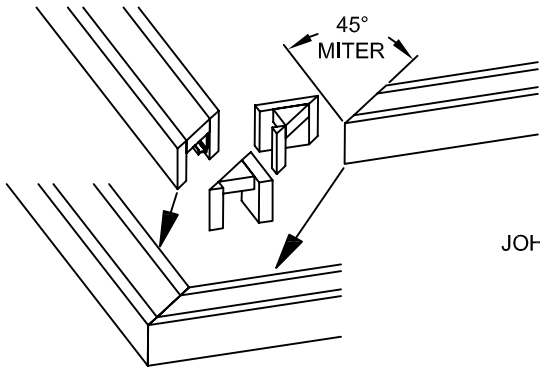

MITER JOHNSON POCKET DOOR HEADER ON 45°

ATTACHING JOHNSON POCKET DOOR HEADERS TO ROUGH OPENING

