

# INSTRUCTIONS

For 2 - 1-3/8" (35mm) Doors  
weighing up to  
200 lbs (90 kgs) each.

## 1562 SERIES BYPASS POCKET DOOR FRAME

1562 MADE FOR 2" X 6" STUD WALLS

### 1562 SERIES SET NUMBERS AND SIZES

15622068 FOR 2-24" (609mm) X 80" (2,03m) Doors  
15622668 FOR 2-30" (761mm) X 80" (2,03m) Doors  
15623068 FOR 2-36" (913mm) X 80" (2,03m) Doors

**CONVERGING DOORS REQUIRE TWO FRAMES AND THE 1556PLBG CONVERGING DOOR KIT.**  
1562 Frames for 7/0, 8/0 Tall Doors available.

**NOTE:** Instructions are for a 80" (2,03m) door, if door is shorter, lower header and cut bottom ends of Split Studs. If taller, order taller 1562 Bypass Pocket Door Frame, i.e. 1562 7/0, 8/0 frames.

- 1 CONSTRUCT ROUGH OPENING:** Header must be **SQUARE** and **PLUMB** with studs and **LEVEL**.  
Minimum Height is Door Height 80" (2,03m) plus 5-3/4" (146mm).  
Rough Opening Width is 3X Door Width plus 7/8" (22mm).

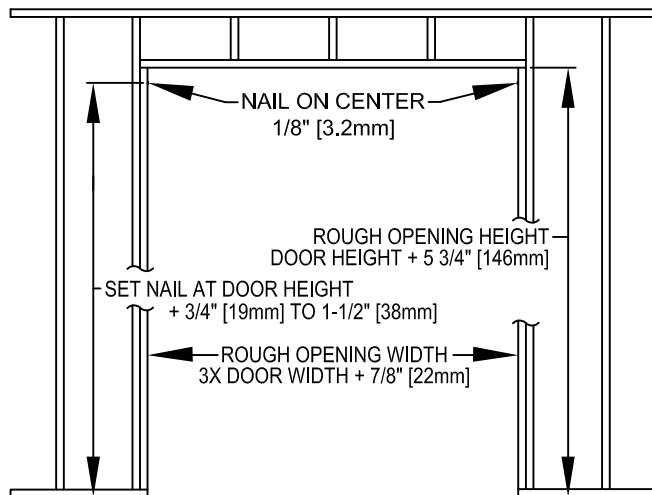

- 2 MEASURE** up from finished floor 80-3/4" (2.05m) or from sub-floor to 81-1/2" (2.07m). This will give 3/4" (19mm) to 1-1/2" (38mm) clearance under door. Mark each rough stud and drive a flat head nail on center, leaving 1/8" (3mm) protruding. (Frame header end brackets will rest on these nails).

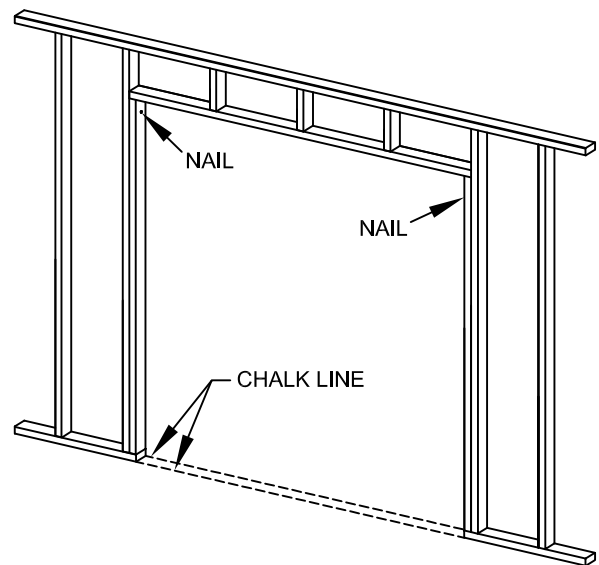

- 3 SNAP** a chalk line on floor even with side jambs.

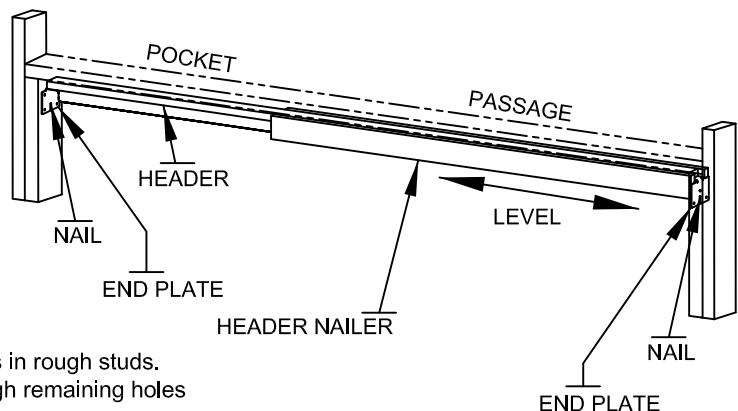

- 4 SLIP** slots in Frame Header End Plates over nails in rough studs. **LEVEL** HEADER. Set nails and drive nails through remaining holes in end plates.

**5 SLIP** fingers of Floor Plate into Split Studs as shown. Screw one pair of studs flush to side of Side Nailer Boards of Header and the other pair midway in the pocket area. Plumb Split Studs between Chalk lines and nail or screw to floor. (On masonry, use industrial adhesive or Tapcon fasteners.)

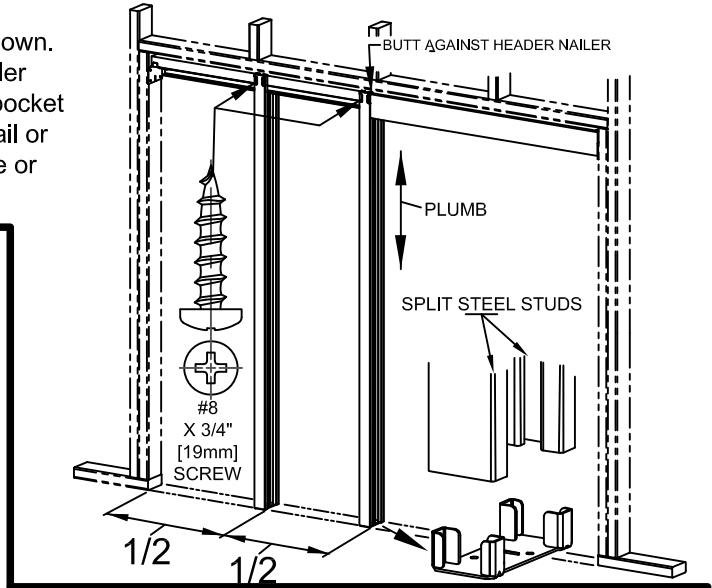
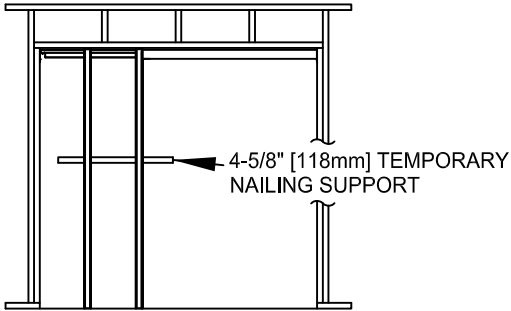

**6** Apply desired wall material with 1" (25.4mm) X #6 Self drilling drywall screws. Use seven (7) screws per Split Steel Stud.

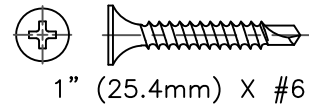

**7 CUT** a clear board 3/4" (19mm) X 3-1/8" (79mm) X Door Height. This will be attached to back of Guide Door to close pocket when opening is closed.



**8 ATTACH** Pocket Closer Board to back edge of Guide Door.

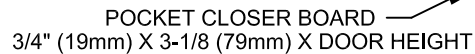

**9 ROUTE** 5/16" (8mm) X 1" (25mm) groove in the center of each doors bottom rail.

**10 MORTISE** ends of Lead Door and front edge of Guide Door for 2040 Groove Cover. 1-1/8" (28.6mm) wide X 1-1/2" (38mm) high X 3/32" (2.3mm) deep.

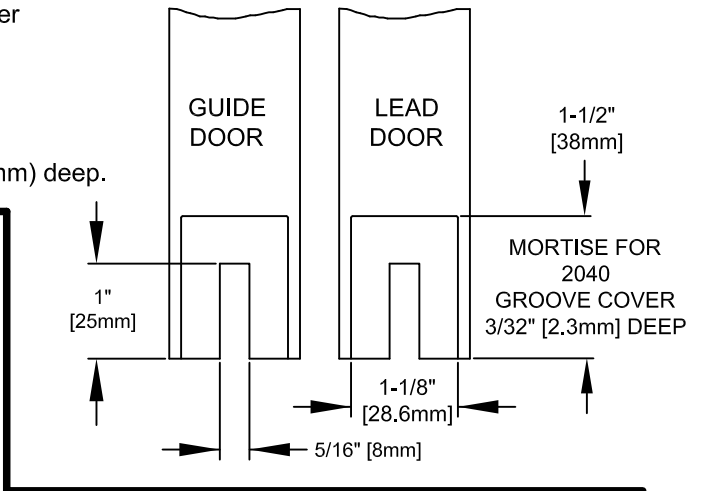
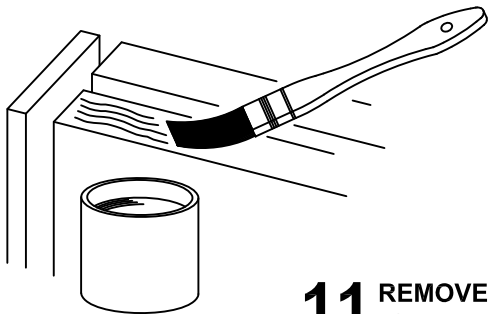

**11 REMOVE** Pocket Closer Board from Guide Door and seal all edges and faces of doors and pocket closer board with paint or sealer stain.

**12 ATTACH** 2032 Side Mount Guide to front face of Guide Door on same side as the Pocket Closer Board extends pass door face.

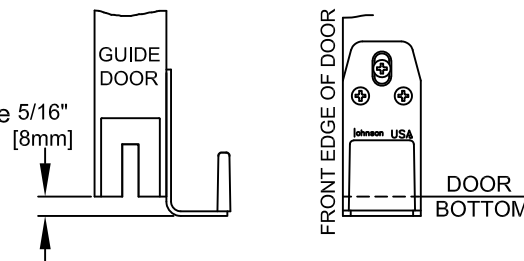

**13 ATTACH** 2054 Pull Catch to top front edge of Guide Door and top rear edge of Lead Door.

VIEW OF 2054 MULTI-DOOR PULL CATCH

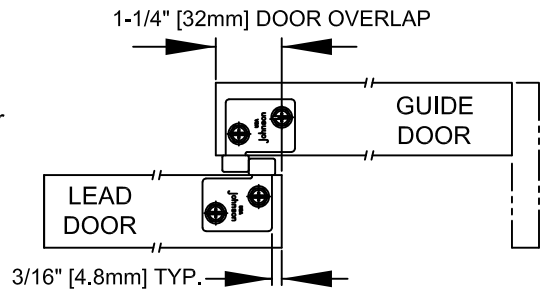

**14 A/Attach** door plate 1121 on top of door 2-3/4" (70mm) from each edge with lock tab on same side.

**B/ Insert** 1125 hangers into tracks alternating wheel wheel positions for even weight distribution.

**C/ Mount** Guide Door by first locating door plate 1121 under adjusting bolt of 1125 Hanger. Lift door and push bolt into door plate. Repeat with other hanger/door plate.

**D/ Mount** Lead Door next to Guide Door in same manner.

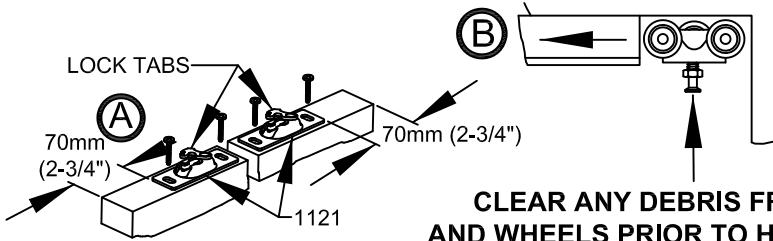
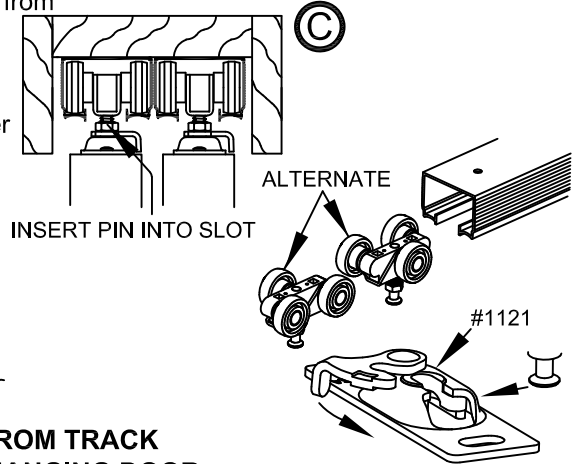

**15 SLIDE** Guide Door and Lead Door to strike Jamb rough stud and reattach Pocket Closer Board to Guide Door.

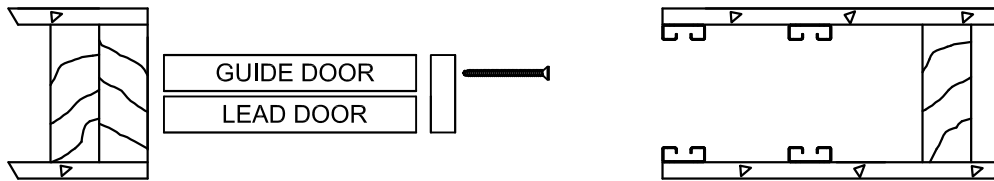

*Note: Side Mount Guide must be in route groove of lead door.*

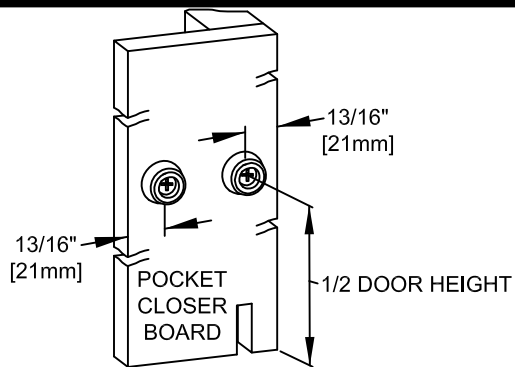

**16 FASTEN** 1513 Bumpers to back of Pocket Closer Board 1/2 the door height from floor. 13/16" (421m) from each edge.

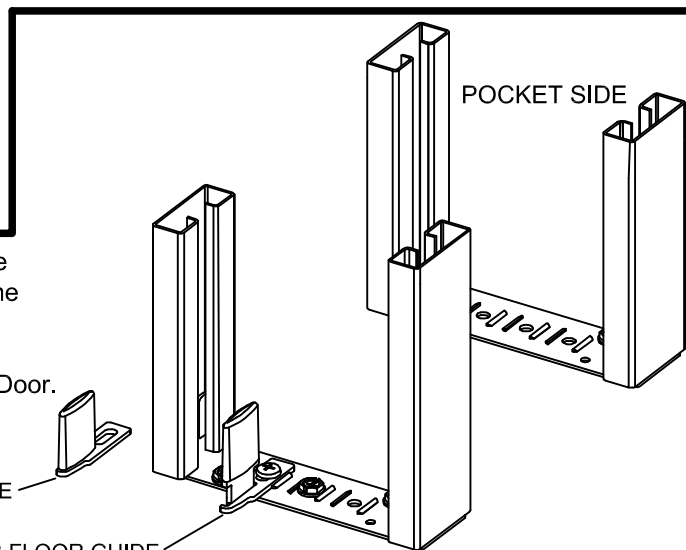

**17 ATTACH** 2041 Guide to floor bracket at edge of pocket opening. Use tall Guide when frame is attached to sub floor or Short Guide when attached to finished floor. Be sure to mount the 2041 on the side you want as the Guide Door.

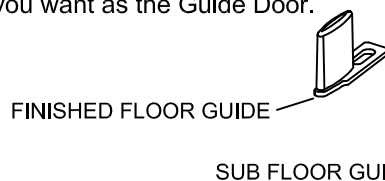

**18 ATTACH** 2040 Route Groove covers in mortised area, both sides of the Lead Door and only the front side of the Guide Door.

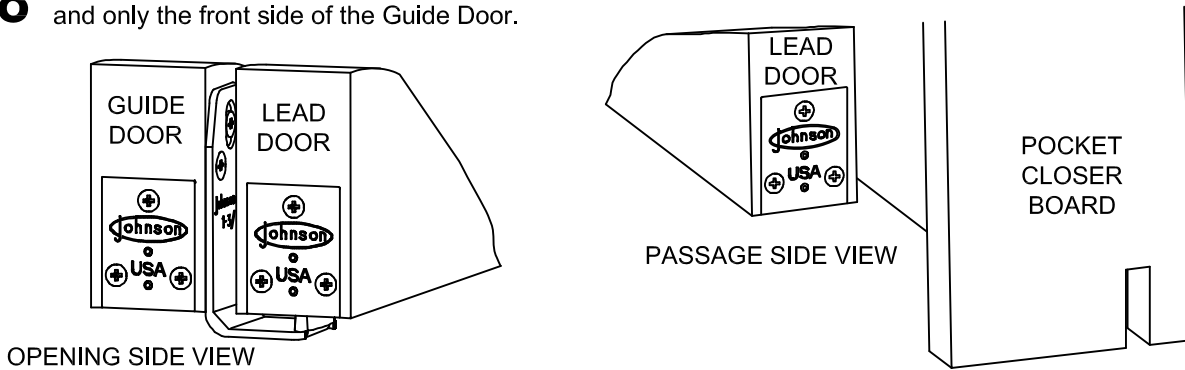

**19 SLIDE** 1155 Stop into Guide door track and adjust until the back edge of the Pocket Closer Board on the guide door is flush with the front edge of the steel wrapped studs.

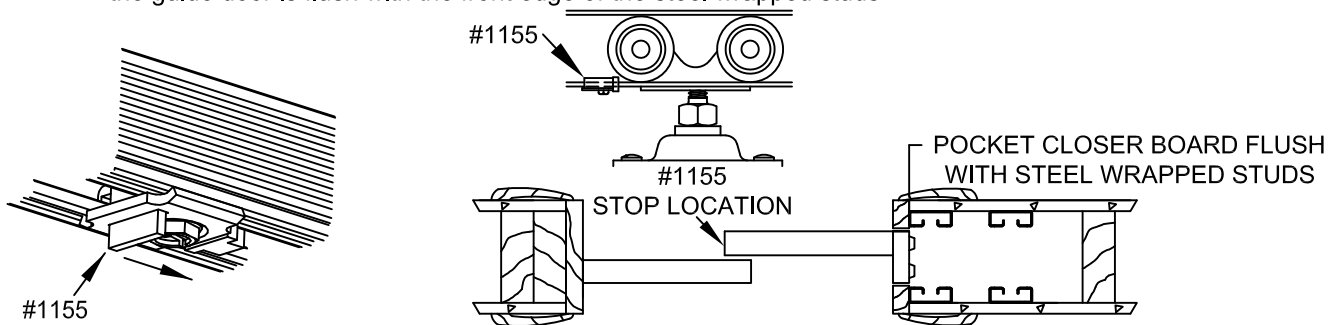

**20 INSTALL** finished jambs, split header and casing as shown. Fasten split header on 1121 lock lever side with screws for future door removal or adjustment. **DO NOT USE JAMBS WITH DADO'S.**

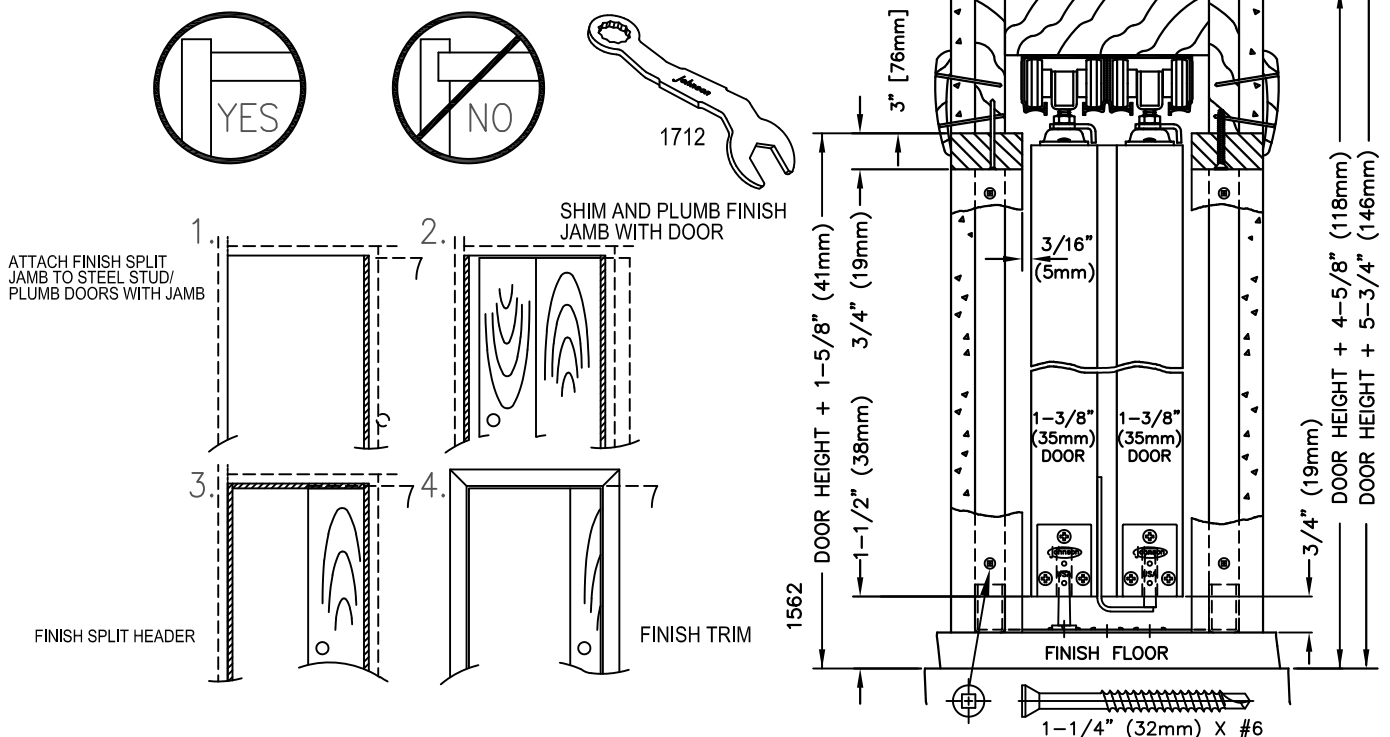

# INSTRUCTIONS

## 1562 SERIES

### Cutting Instructions-Johnson Hardware Pocket Door Frame Header

- 1** Mark Header and Side Nailers for door size.

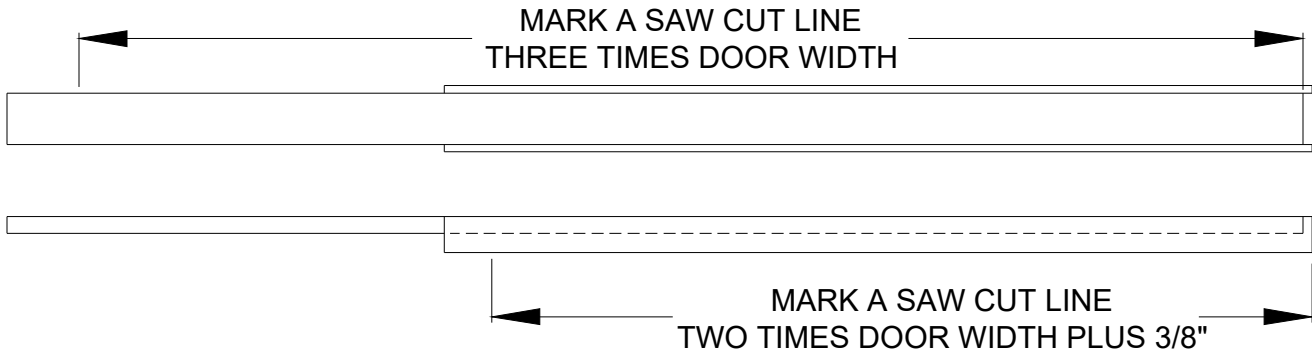

- 2** Remove Adjustable End Bracket.

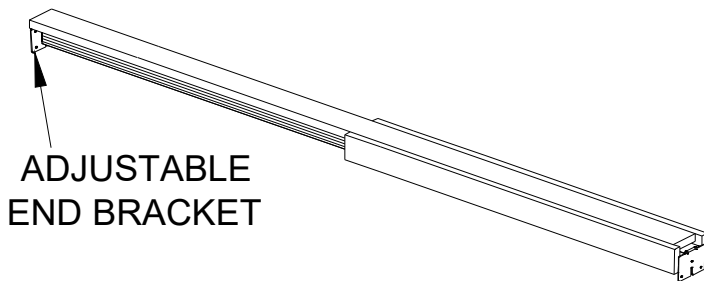

- 5** Replace Adjustable End Bracket on new cut end of header.

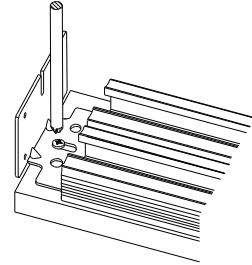

- 3** Cut through WOOD part of header only at mark.

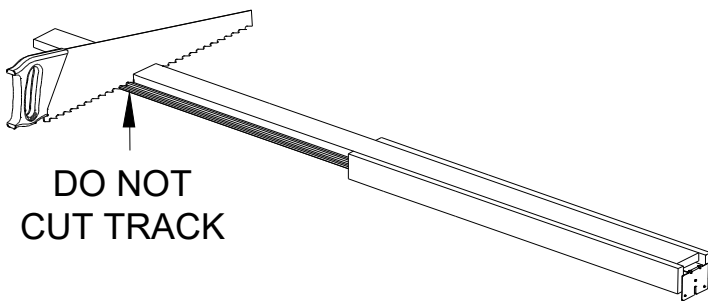

- 6** Turn Header on side and cut Side Nailer Trim Board ONLY at mark. Remove cut off end and discard.

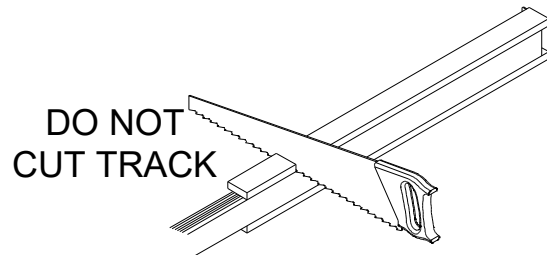

- 4** Turn Header over and cut Tracks 1-3/8" shorter than wood Header.

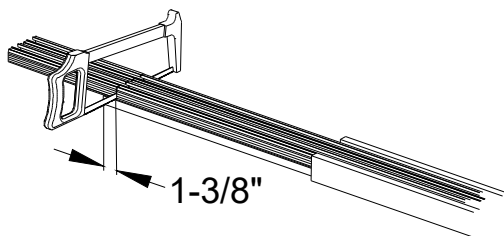

- 7** Repeat step #6 on the other Side Nailer Trim Board.

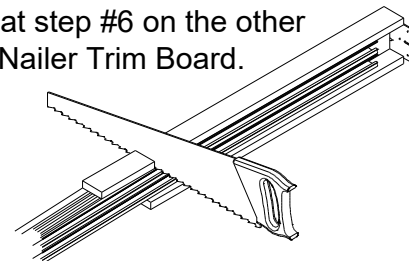

# INSTRUCTIONS

## Cutting Instructions for unmarked frames or non standard door widths

**1** Mark Header and Side Nailers for door size.

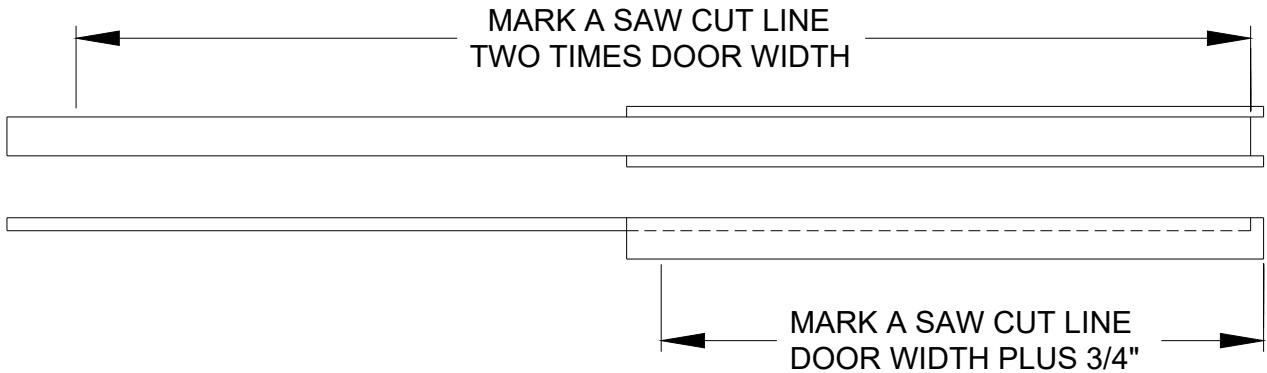

**2** Remove Adjustable End Bracket.

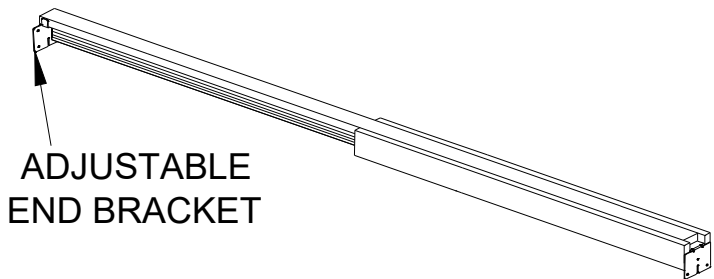

**5** Replace Adjustable End Bracket on new cut end of header.

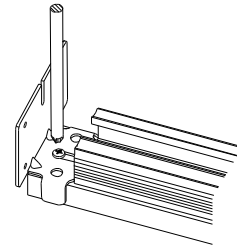

**3** Cut through WOOD part of header only at mark.

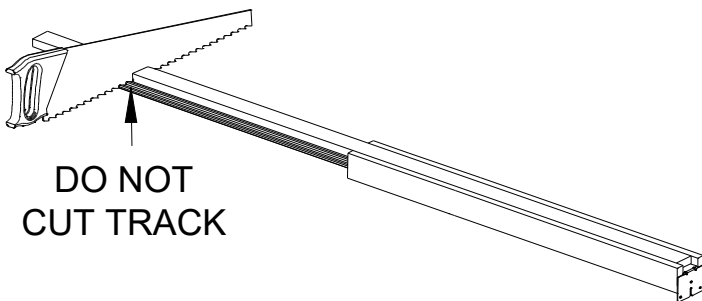

**6** Turn Header on side and cut Side Nailer Trim Board ONLY at mark. Remove cut off end and discard.

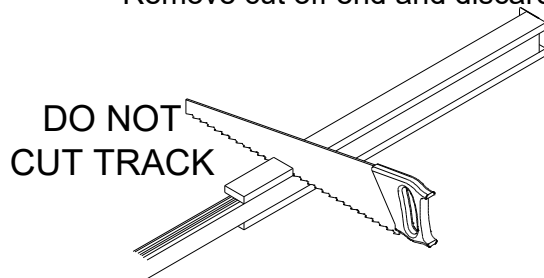

**4** Turn Header over and cut Track 1-3/8" shorter than wood Header.

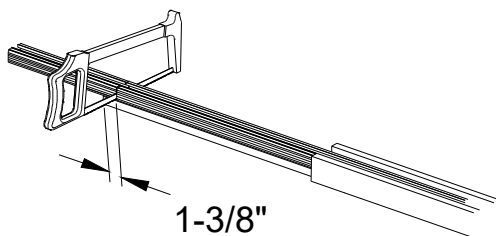

**7** Repeat step #6 on the other Side Nailer Trim Board.

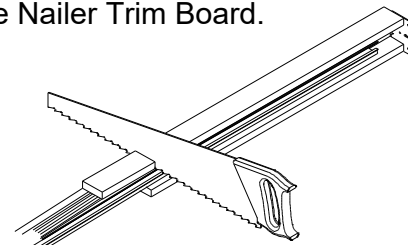



www.johnsonhardware.com

# INSTRUCTIONS

## SPECIAL APPLICATIONS

### INTERSECTING WALLS

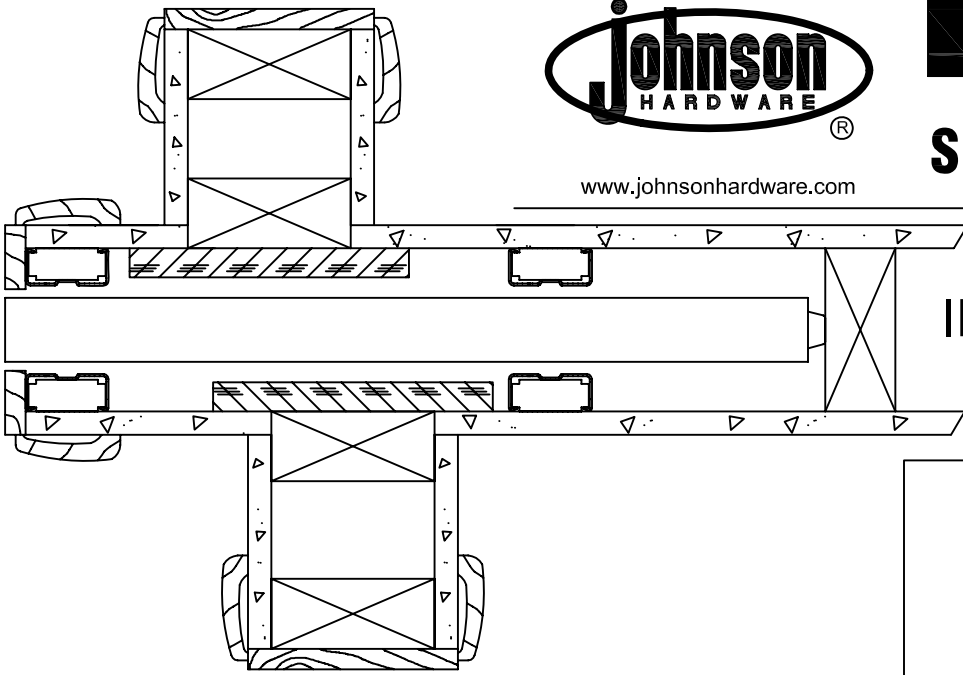

### DOOR SWEEP

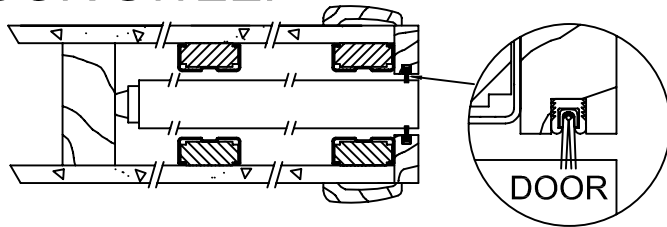

● PEMKO 5025\_p

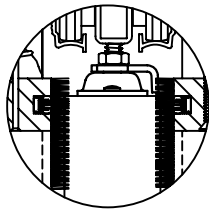

3/16" (5mm)

3/4" (19mm)

DOOR HEIGHT + 4-1/2" (114mm)

1/8" (3.2mm)

No. 6 x 5/8" PHSMS, Phillips (Factory Provided)

● PEMKO 90062\_P

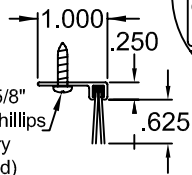

### TRANSOM

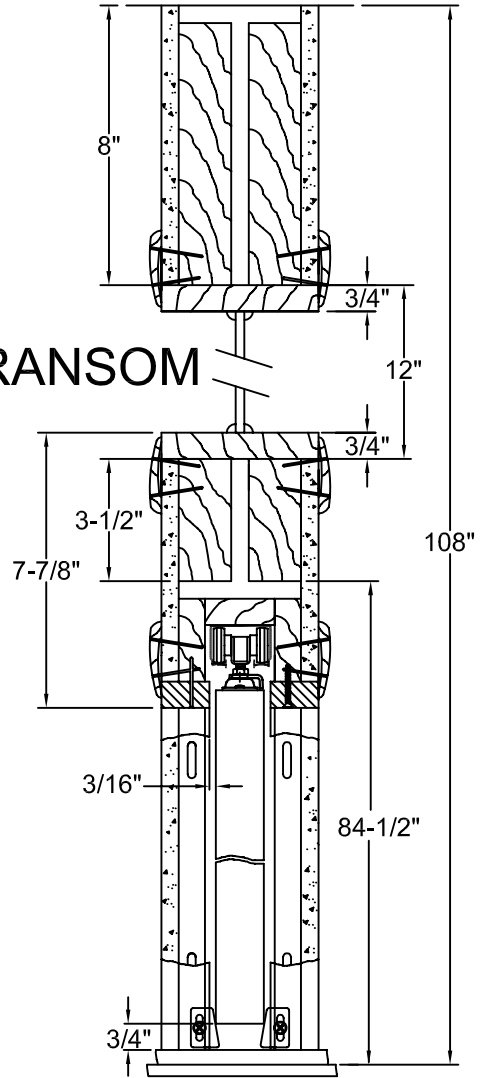

### BI - PARTING POCKET DOOR

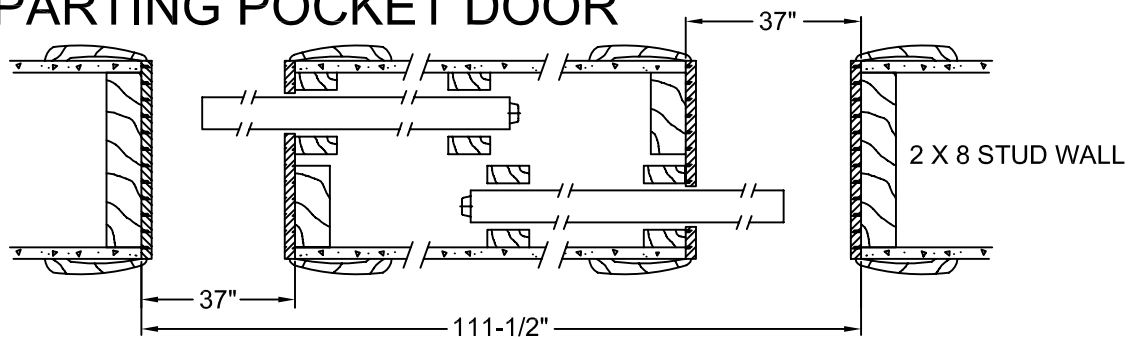

# INSTRUCTIONS

FOR USE WITH  
100PD/1500/1560/1562  
POCKET DOOR HARDWARE

## 1060 SOFT CLOSE POCKET

MAXIMUM DOOR WEIGHT  
165 lbs. (75kg)

### 100PD/1500/1560/1562 Pocket Door Instructions:

Instructions are for installing the 1060 Soft Close in a Pocket Door Frame using JOHNSON 100 Series Track.  
Minimum Door Thickness 1" (25mm)

28" [711MM] Minimum Door Width for bi-directional soft door operation.

20" [508mm] Minimum Door Width for single direction soft door operation.

\*\*\*Single direction soft door operation requires additional 1125 Door Hanger NOT INCLUDED.\*\*\*

#### Following steps are for soft close.

- 1 IF FRAME is already installed, disconnect Hangers from Door Plates and remove door. Remove both Hangers from track-Remove Door Plates from door.
- 2 ATTACH 1121 Door Plates 2-3/4" (70mm) from door edge.
- 3 INSERT 1125 Ball Bearing Hanger Wheel assembly into Track.
- 4 Engage Soft Close Dampener by pushing Dampener trigger toward 3 Wheel Roller. This step is very important. DAMPENERS MUST BE ENGAGED or soft close will not work, 1060 Soft Close Dampener may be DAMAGED if installed incorrectly. Door will have to be removed and installation of 1060 will have to begin again.

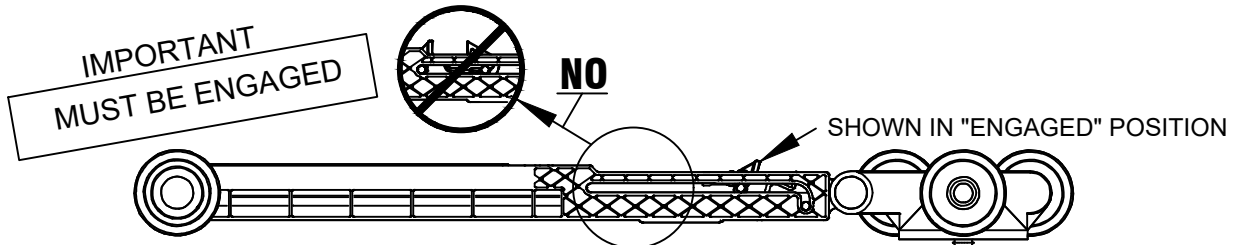
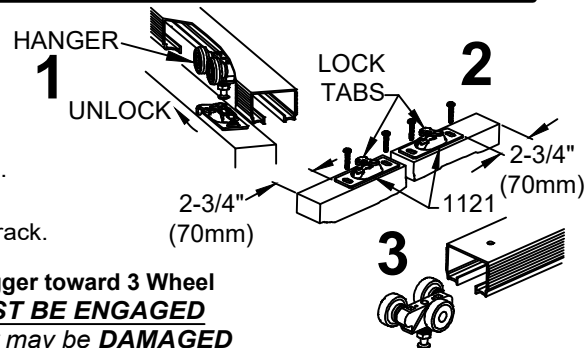

- 5 INSERT 1060 into Track. (Idle wheels first).

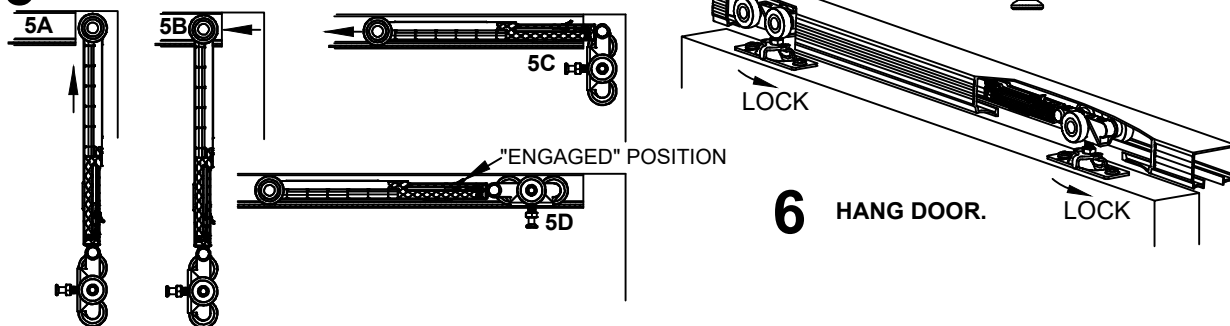

- 7 SLIDE door away from end of track (check to make sure all track screws are flat against track and does not interfere with movement of dampener hanger) and install 1060 Actuator Arm into track, with back of Actuator Arm 2-1/4" (57mm) from Jamb. **HAND TIGHTEN** (do not use power drill) Actuator Arm on track. Check to make sure Arm stayed straight in track. Slowly close door, checking to make sure door touches Jamb, if not. Slide door away from Jamb and readjust Actuator Arm. Slowly close door again, checking to make sure soft close is working properly. Once confirmed, begin using door normally.

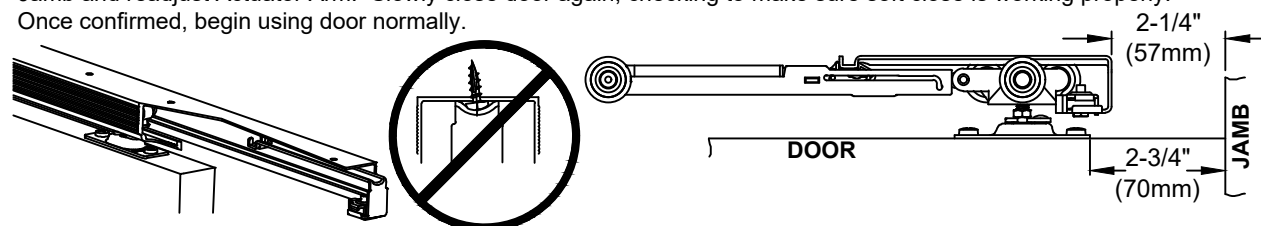



Following steps are for soft open. Skip steps 1-3 if new installation.

- 1** IF FRAME is already installed, disconnect Hangers from Door Plates and remove door. Remove both Hangers from track-Remove Door Plates from door.
- 2** CUT ACCESS HOLE by measuring door width and door height, then on pocket wall, measure over door width minus 2" (51mm) and door height minus 2" (51mm). Then from that mark, measure down 8" (203mm) and over toward opening 8" (203mm). Cut square in wall to access track.



- 3** CHECK to make sure all track screws are flat against track. DISASSEMBLE ACTUATOR ARM, (with backside of arm facing pocket), insert arm, bumper and lock nut into track and reassemble. Slide assembly into pocket until backside of Actuator Arm is 2-1/4" (57mm) plus the finish Split Jamb thickness from the rough stud. **Example 2-1/4" (57mm) + 7/16" (11mm) Finish Jamb = 2-11/16" (68mm).** Hand tighten Actuator Arm (do not use power drill). Check to make sure Arm remains straight in track.

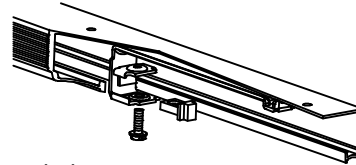

- 4** IF NEW INSTALLATION insert Actuator Arm as shown below.

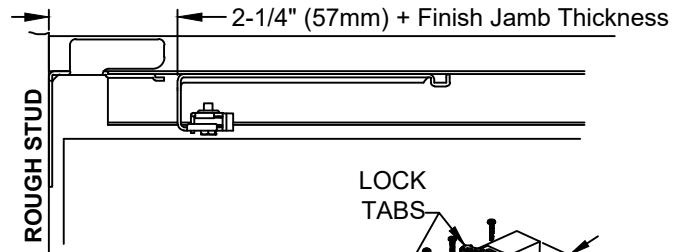
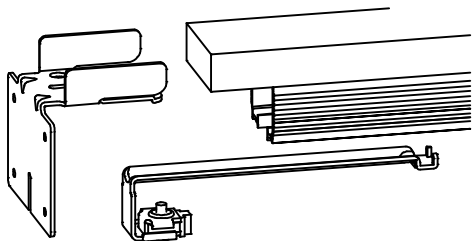

Remove Bracket, Install Actuator Arm, Reattach Bracket.

- 5** ATTACH 1121 Door Plates 2-3/4" (70mm) from door edge.
- 6** Engage Soft Close Dampener by pushing Dampener trigger toward 3 wheel roller. *This step is very important. DAMPENER MUST BE ENGAGED* or soft close will not work, 1060 Soft Close Dampener may be **DAMAGED** if installed incorrectly. Door will have to be removed and installation of 1060 will have to begin again.



**IMPORTANT**  
MUST BE ENGAGED

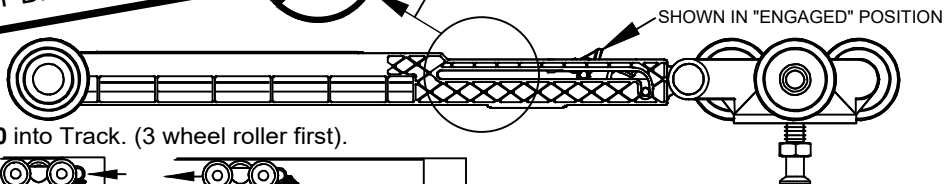
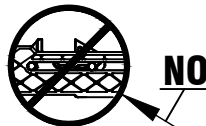

- 7** INSERT 1060 into Track. (3 wheel roller first).

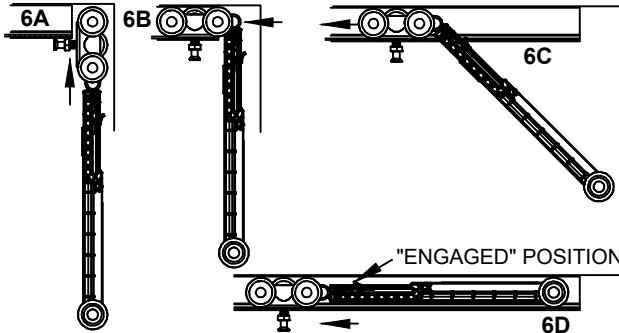

- 8** INSERT 1125 Ball Bearing Hanger Wheel assembly into Track.

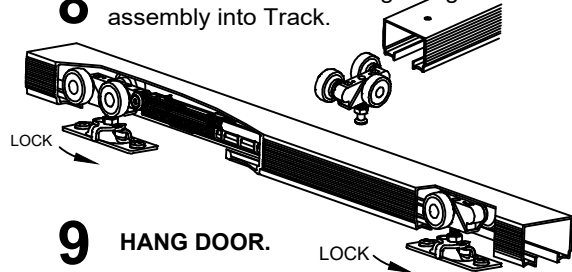

- 9** HANG DOOR.

- 10** SLOWLY slide door into pocket, checking to make sure door opens flush with Split Jamb, if not, slide door out of pocket and readjust Actuator Arm. Slowly open door again, checking to make sure soft close is working properly. Once confirmed, begin using door normally. When installing 1513 bumper on back of door make sure it bumps rough stud at same time as dampener hanger bumps Actuator bumper.

- 11** PATCH the wall.

# INSTRUCTIONS

FOR USE WITH TWO JOHNSON  
1562 BYPASS  
POCKET DOOR FRAMES

www.johnsonhardware.com

## 1556 CONVERGING DOOR KIT

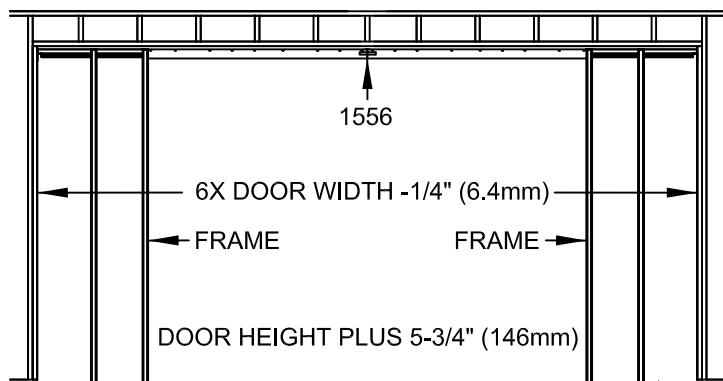

ROUGH OPENING WIDTH IS SIX TIMES DOOR WIDTH - 1/4" (6.4mm)

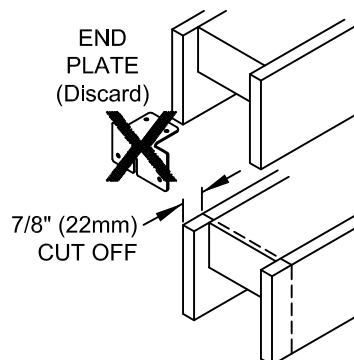

### 1556PLBG CONVERGING DOOR KIT For joining two Johnson 1562 Pocket Door Frames

- Remove and discard end plates from "door opening" end of each header.
- Cut 7/8" (22mm) from length of each header (wood part only) where discarded end plates had been located. Cut ends square to keep header straight when joined.

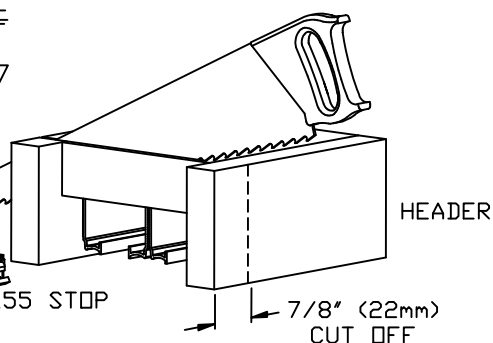
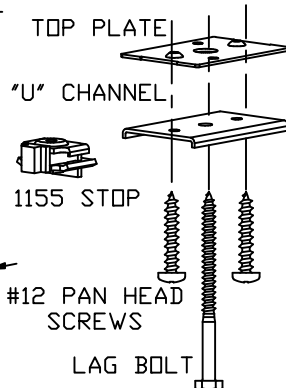
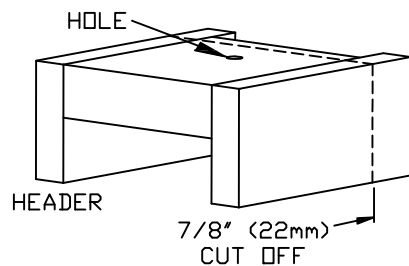
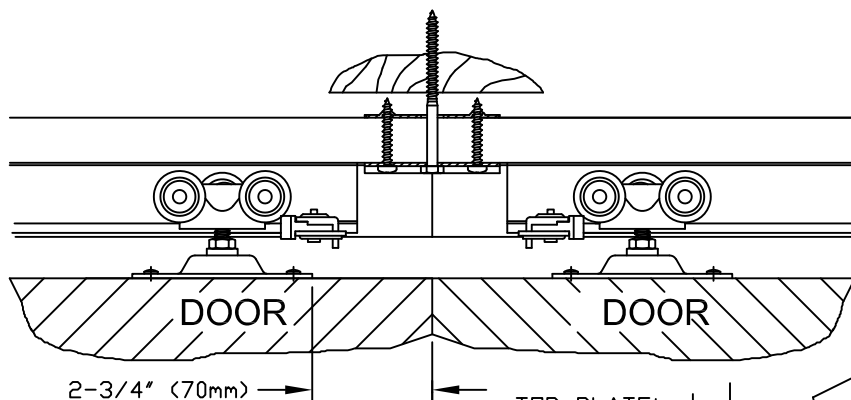

- Butt cut ends together and insert "U" channel, aligning cut ends of headers with center mark stamped in channel. Using channel as guide, drill two 3/16" (4.7mm) holes through headers at outer channel holes. Insert screws through these holes and into top plate on top of header. Tighten, forming a one-piece header.
- Drill a 1/4" (6.3mm) hole at channel center where header ends meet to enable the lag screw to be fastened into rough header for increased center support.
- Insert stops into track and leave loose until doors are hung, then tighten. Proceed with regular frame assembly instructions.

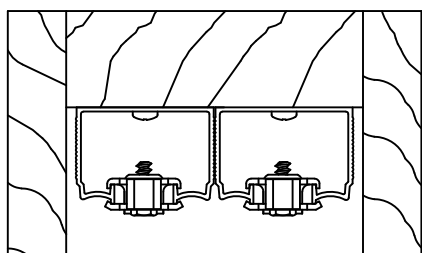

# INSTRUCTIONS

## 2041 PDF BOTTOM GUIDE SET

FOR USE WITH JOHNSON  
2000, 2060, 1500, 1560, 2511  
POCKET DOOR FRAMES

**1** ROUT 5/16" (8mm) X 1" (25mm) groove in bottom of Door.

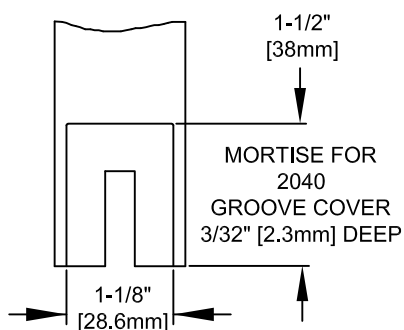
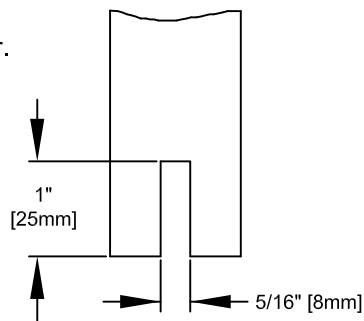

**2** MORTISE end of Door's front edge for 2040 Groove Cover. 1-1/8" (28.6mm) wide X 1-1/2" (38mm) high X 3/32" (2.3mm) deep.

**3** ATTACH 2041 Guide to floor bracket located at edge of front pocket opening. Use tall guide if Frame Floor Bracket is attached to the sub-floor or the short guide when it is attached to finished floor.

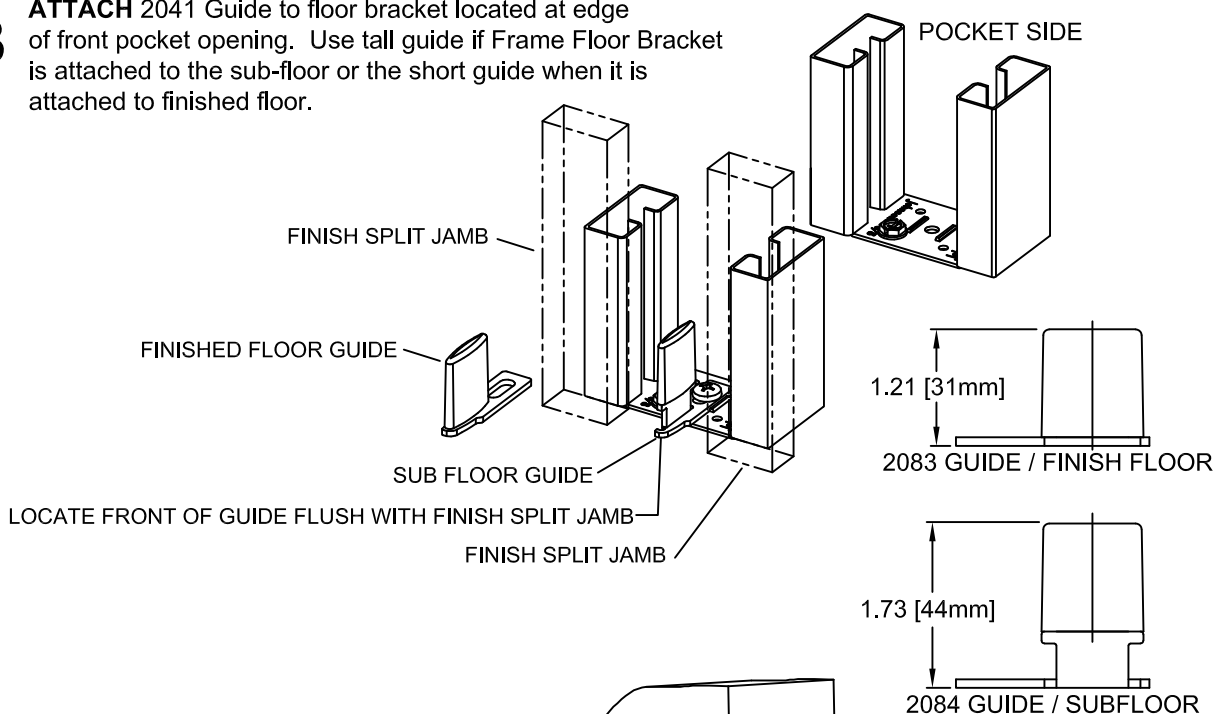

**4** ATTACH 2040 Rout Groove Cover in mortise area.

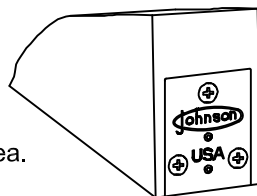

PASSAGE SIDE VIEW



www.johnsonhardware.com

# INSTRUCTIONS

## 2054 Multi-Door Pull Catch

FOR USE WITH TWO OR MORE  
SLIDING DOORS

MINIMUM DOOR  
THICKNESS 1" [25mm]

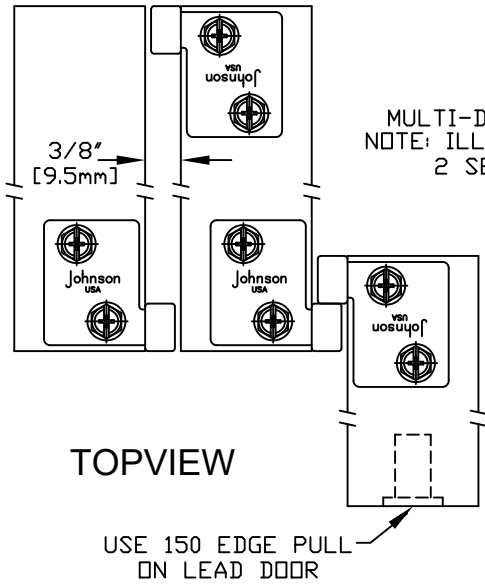

2054  
MULTI-DOOR PULL CATCH  
NOTE: ILLUSTRATION SHOWS  
2 SETS OF 2054

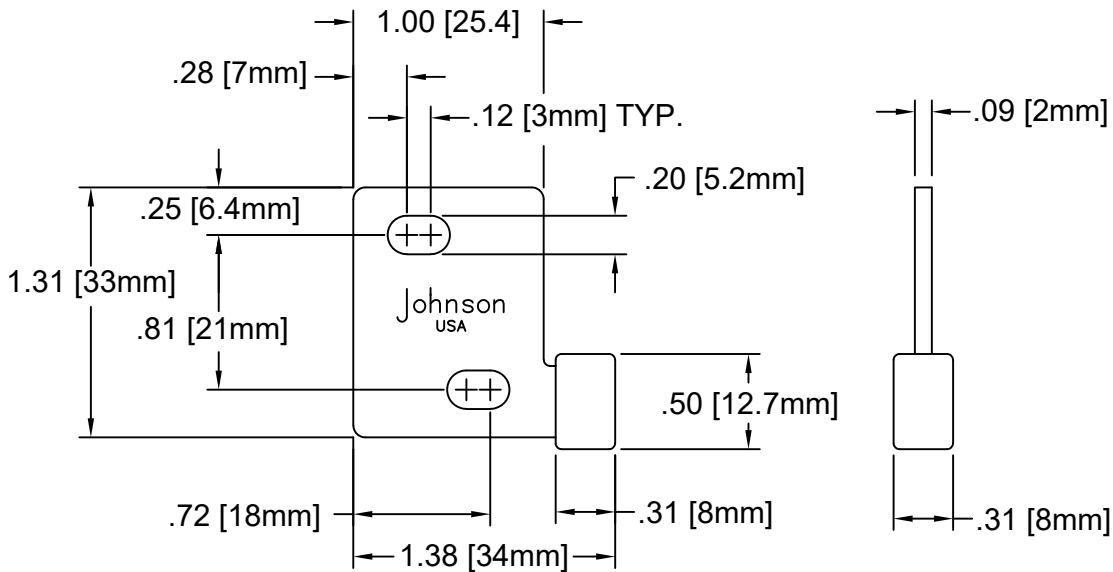
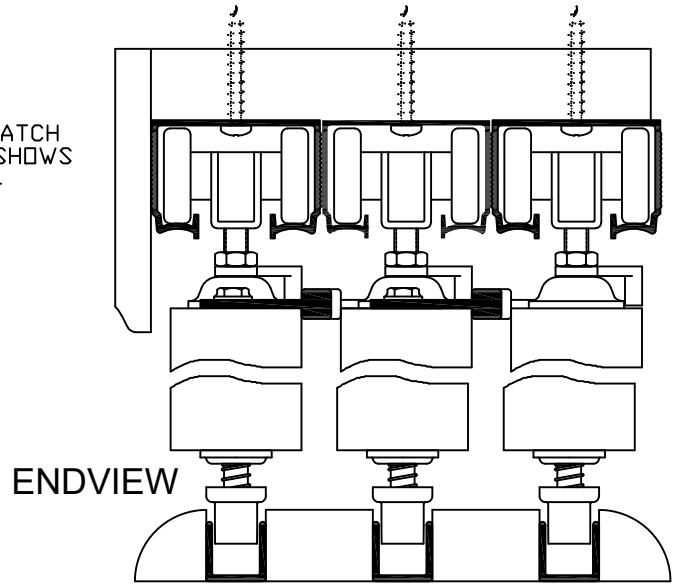

2054 MULTI-DOOR  
PULL CATCH

# CONVERGING CORNER POCKET

USE APPROPRIATE SIZE LAG BOLT TO SECURE THRU JOHNSON HEADERS  
TO ROUGH POCKET DOOR OPENING HEADERS

USE TWO #12 PAN HEAD SCREW TO FASTEN  
BRACKET TO JOHNSON POCKET DOOR HEADER

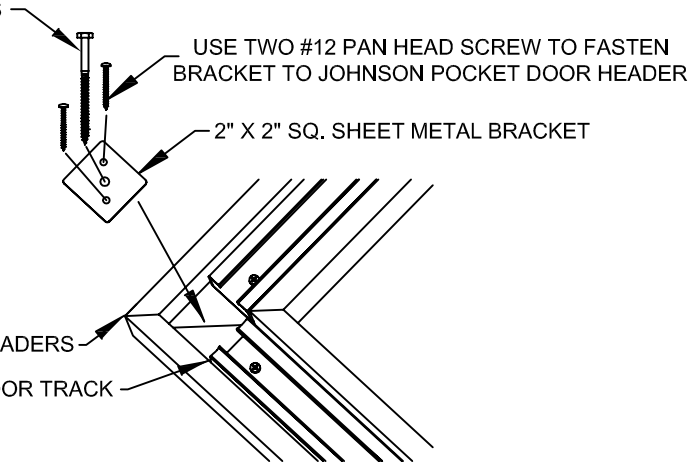
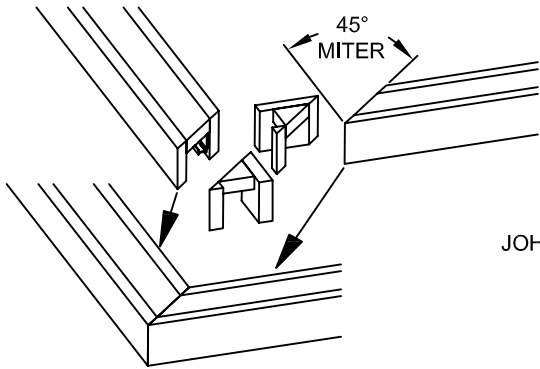

JOHNSON POCKET DOOR HEADERS

JOHNSON POCKET DOOR TRACK

MITER JOHNSON POCKET DOOR HEADER ON 45°

ATTACHING JOHNSON POCKET DOOR HEADERS TO ROUGH OPENING

