

INSTRUCTIONS

1500SC SERIES POCKET DOOR FRAME

1500SC MADE FOR 2" X 4" STUD WALLS

For 1" (25mm) to 1-3/4" (45mm) doors to 165 lbs. (75 kgs).
Para puertas de 25mm a 45mm y de hasta 75 kg.
Pour portes de 25mm à 45mm pesant 75 kg.

IMPORTANT

28" (711mm) Minimum Door Width
for Soft Close & Open.
20" (508) Minimum Door Width
for Soft Close or Soft Open.

1500SC SERIES SET NUMBERS AND SIZES

152468SC FOR 1-28" (710mm) X 80" (2,03m) Door, Puerta, Porte
**152668SC FOR 1-30" (761mm) X 80" (2,03m) Door, Puerta, Porte
152868SC FOR 1-32" (812mm) X 80" (2,03m) Door, Puerta, Porte
**153068SC FOR 1- 36" (913mm) X 80" (2,03m) Door, Puerta, Porte
**All purpose frames, marked to cut to shorter lengths.

**Marcos universales, marcados para ser cortados a longitudes menores.

**Montants à usage multiple, marqués pour être coupés plus court.

CONVERGING DOORS REQUIRE TWO FRAMES AND THE 1555 CONVERGING DOOR KIT.

Frames for Doors up to 48" (1.2m) wide and 96" (2.44m) high are available.

Hay marcos disponibles para Puertas de hasta 1,2m de ancho 2,44m de alto.

Des montants pour Portes jusqu'à 1,2m en largeur et 2,44m en hauteur sont disponibles.



USE
QR CODE
TO
ORDER
1555

NOTE: Instructions are for a 80" (2,03m) door, if door is shorter, lower header and cut bottom ends of Split Studs, if door is taller than 80" (2m), order longer Split Studs and raise header.

NOTA: Las instrucciones son para una puerta de 2,03m. Si la puerta es mas corta, baja la cabecera y corte los extremos de abajo de las jambas divididas. Si la puerta es más alta que 2,03m, ordene piezas verticales más largas y suba la cabecera.

NOTE: Les instructions se réfèrent à la porte de 2,03m, Si la porte est plus petite, abaissez le guide et coupez les extrémités des montants de séparation. Si la porte est haute que 2,03m, commandez des montants plus longs et rehaussez le guide.

- 1 CONSTRUCT ROUGH OPENING** Header must be **SQUARE** and **PLUMB** with studs and **LEVEL**. Minimum Height is 84 1/2" (2,14m) width is 2X Door width plus 1" (25mm).

CONSTRUYA LA ABERTURA PRELIMINAR. La cabecera debe de estar en **ESCUADRA** y **A PLOMO** con los montantes y a **NIVEL**. La Altura Minima es de 2,14m, el Ancho es de 2X Ancho de Puerta mas 25mm.

CONSTRUISEZ L'OUVERTURE BRUTE. Le guide doit être perpendiculaire et d'aplomb avec les montants ainsi qu'à niveau. La hauteur minimale est de 2,14m. La largeur correspond à 2X porte plus 25mm.

- 2 Measure** up from finished floor 80-3/4" (2.05m) or from sub-floor to 81-1/2" (2.07m). This will give 3/4" (19mm) to 1-1/2" (38mm) clearance under door. Mark each rough stud and drive a flat head nail on center, leaving 1/8" (3mm) protuding. **(Frame header end brackets will rest on these nails).**

Mida 2.05m desde el piso terminado ó 2.07m desde el sub-piso. Esto dará una separación de 19mm hasta 38mm debajo de la puerta. Marque cada montante y clave un clavo de cabeza plana en el centro de cada una, dejando 3mm afuera, **(Los soportes de los extremos de la cabecera del marco se apoyaran en estos clavos).**

Mesurez 2,05m à partir du sol fini ou bien 2,07m à partir du sous plancher. Ce qui va donner un jeu de 19mm à 38mm sous la porte. Marquez chaque montant et enfoncez un clou à tête plate au centre, en laissant dépasser 3mm. **(Les crochets du linteau reposeront sur ces clous).**

- 3 Snap** a chalk line on floor even with side jamb.
Marque una linea con un cordel entizado en el piso que concuerde con las jambas laterales.

Tracez à craie une ligne au sol parallèle aux montants latéraux.

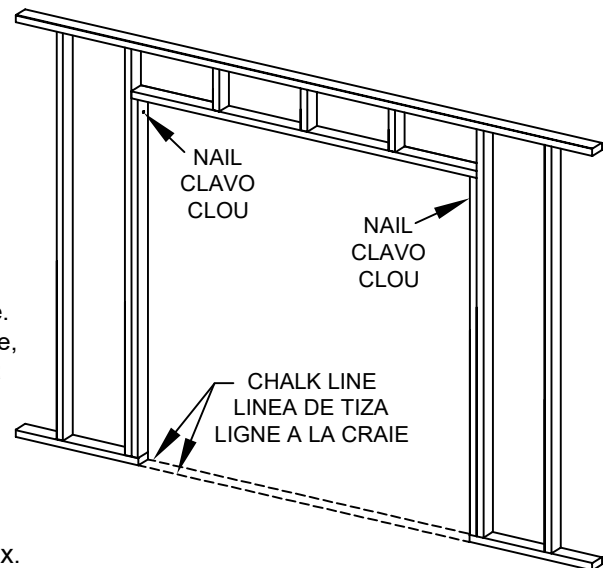
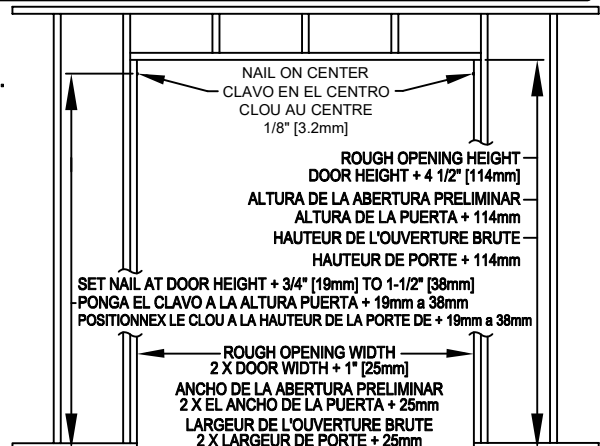

4 Slip slots in Frame Header End Plates over nails in rough studs. LEVEL HEADER. Set nails and drive nails through remaining holes in end plates. (If you have the 2/6" (761mm) or Universal Frame and using another size door, see cutting instructions on page 4.)

Encaje la ranuras que estan en las Placas de los Extremos de la Cabecera del Marco en los clavos que estan en los montantes. Alinee los clavos y clavos en los orificios restantes en las placas de los extremos. (Si usted tiene el Marco de 761mm o el Marco Universal y esta usando puerta de otro tamaño, vea las instrucciones de corte en la página 4.)

Glissez les encoches des extrémités du linteau sur les clous fixés dans les montants bruts. Mettez le guide à niveau. Positionnez les clous et enfoncez les au travers des trous restants dans les plaques des extrémités. (Si vous avez le montant universel ou de 761mm et utilisez une dimension de porte différente, référez vous aux intructions de coupe page 4.)

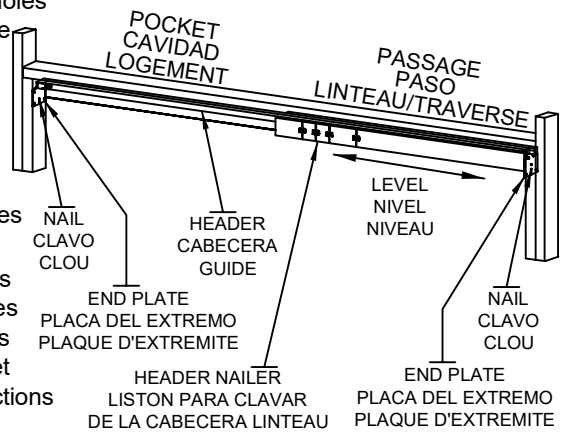

5 Slip fingers of Floor Plate into Split Steel Studs as shown. Butt Split Steel Studs against header nailer and screw into place with two (2) 3/4" (19mm) X #8 Pan Head Screws. Attach other Split Steel Studs midway in "Pocket" opening. Plumb Split Steel Studs between chalk lines and nail to floor. (On masonry, use industrial adhesive or Tapcon fasteners.)

Encaje las aletas de la Placa del Piso en las Jambas Divididas tal como se muestra. Una a tope las jambas divididas contra el listón para clavar de la cabecera y atornillelas en su sitio con dos (2) tornillos de cabeza troncocónica #8 X 19mm. Coloque otras jambas divididas en un lugar intermedio de la abertura de la "Cavidad". Alinee a plomo las jambas divididas entre las líneas de tiza y clávelas al piso. (En el caso de mampostería, use un adhesivo de tipo industrial o sujetadores Tapcon.)

Glissez tel qu'illustré les doigts de la plaque de plancher dans les montants de séparation. Calez ces derniers contre le linteau et fixez en place à l'aide de deux (2) vix No. 8 à tête tronconique de 19mm. Attachez le second montant de séparation au centre de l'ouverture de la poche. Mettez d'aplomb les montants de séparation entre les tracés de craie et clourz au sol. (Sur de la maçonnerie, utilisez un adhésif industriel ou de boulons Tapcon.)

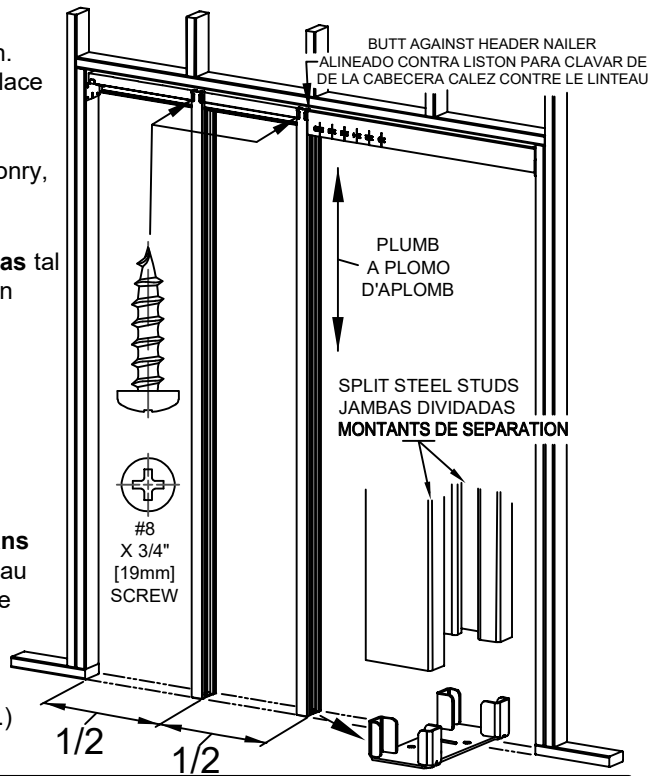

6 Apply desired wall material with 1" (25.4mm) X #6 Self drilling drywall screws. Use seven (7) screws per Split Steel Stud.

Coloque el material deseado para la pared con tornillos autoperforantes para tablero de yeso #6 X 25.4mm. Use siete (7) tornillos por jamba dividida.

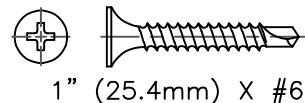

Posez le matériau mural désiré en utilisant des vis auto taraudeuses No. 6 pour cloison sèche de 25.4mm. Utilisez sept (7) vis pour chaque montant séparateur.

7 Seal all edges and face of door panel with paint or sealing stain.

Selle todos los bordes y la superficie del entrepaño de la puerta con pintura o barniz para sellar.

Recouvrez de peinture ou de teinture tous les cotés et toutes les faces des panneaux de porte.

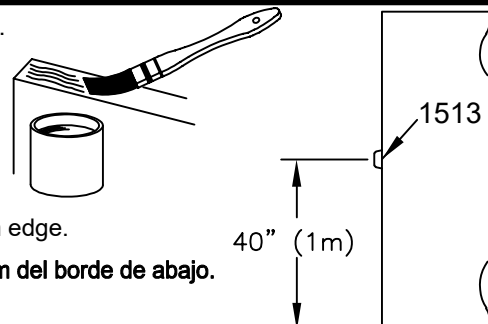

8 Fasten 1513 Bumper on back edge of door 40" (1m) from bottom edge.

Coloque el Tope 1513 en el borde de la parte trasera de la puerta y a 1m del borde de abajo.

Fixez le butoir réf. 1513 sur coté de la porte à 1m du bas.

- 9** **A/Attach** door plate 1121 on top of door 2-3/4" (70mm) from each edge with lock tab on same side.
B/ Mount door by locating door plate 1121 under adjusting bolt of 1060 hanger. Lift door and push bolt into door plate. Repeat with other hanger/door plate.

A/ Coloque la placa de la puerta 1121 sobre la puerta a 70mm de cada borde con las aletas de ajuste en el mismo lado.

B/ Instale la puerta ubicando la placa de la puerta 1121 por debajo del perno de ajuste del colgador 1060. Levante la puerta y empuje el perno dentro de la placa de la puerta. Repita con el otro colgador/placa de la puerta.

A/ Fixez les attaches de porte 1121 au haut de la porte, à 70mm de chaque coin avec les loquets de fixation orientés du même côté.

B/ Montez la porte en placant l'attache 1121 sous la vis ajustable de la roulette 1060. Soulevez la porte et poussez la vis dans l'attache de porte. Répétez l'opération avec l'autre roulette et attache de porte.

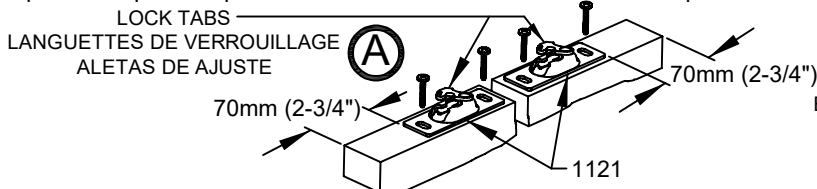

CLEAR ANY DEBRIS FROM TRACK AND WHEELS PRIOR TO HANGING DOOR.

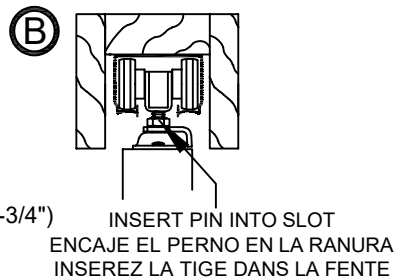
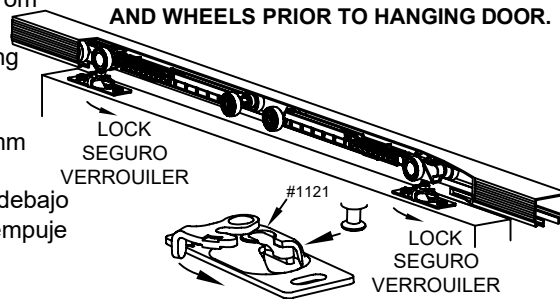

- 10** **Install** finished jambs, split header and casing as shown. Fasten split header on 1121 lock lever side with screws for future door removal or adjustment. **DO NOT USE JAMBS WITH DADO'S.**

Note: minimum 3/16" (5mm) clearance between jamb and door.

Instale los batientes terminados, el cabecero dividido y el contramarco, como se muestra. Sujete con tornillos el cabecero dividido en el lado de la palanca de seguro 1121 para su remoción o ajuste futuros.

NO UTILICE BATIENTES CON DADO'S.

Nota: Debe haber una separación mínima de 5mm entre la jamba y la puerta.

Installez les montants finis, le linteau de séparation et le contre-chambranle comme illustré. Serrez le linteau de séparation avec des vis du côté du levier de verrouillage 1121 en prévision d'une éventuelle dépose ou d'un ajustement futur.

NE PAS UTILISER DES MONTANTS AVEC DES LAMBRIS D'APPUI.

Nota: Laissez un jeu de 5mm au minimum entre le montant et la porte.

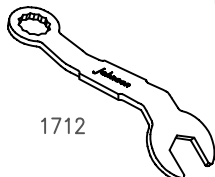
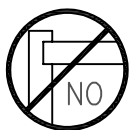

ATTACH FINISH SPLIT JAMB TO STEEL STUD/ PLUMB DOOR WITH JAMB

COLOQUE LA JAMBA DIVIDIDA TERMINADA EN EL PERNO DE ACERO/ NIVELE A PLOMO LA PUERTA CON LA JAMBA

ATTACHER LE MONTANT DE SEPARATION AU SUPPORT EN ACIER/ METTRE D'APLOMB LE MONTANT AVEC LA PORTE

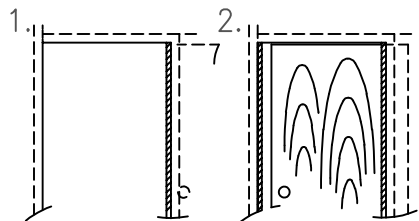

SHIM AND PLUMB FINISH JAMB WITH DOOR
 PONGA CUÑAS Y NIVELE A PLOMO LA JAMBA TERMINADA CON LA PUERTA
 CLAIR METTRE D'APLOMB LE MONTANT DE FINITION AVEC LA PORTE

FINISH SPLIT HEADER
 CABECERA DIVIDIDA TERMINADA
 MONTANT DE SEPARATION FINITION

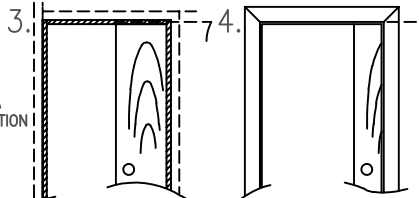

FINISH TRIM
 BORDE TERMINADO
 BAGUETTE DE FINITION

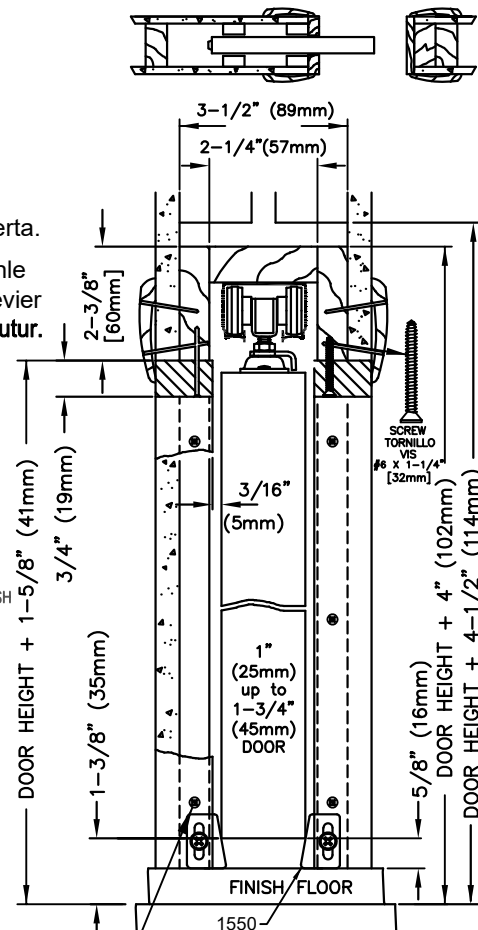

- 11** **Fasten** 1550 Guides on finished split jambs at door bottom so door is held in center of opening.

Coloque las guías 1550 en las jambas divididas terminadas, en la parte de abajo de la puerta para que ésta sea sostenida en la mitad de la abertura.

Fixez les guides 1550 sur les montants de séparation au bas de la porte, de sorte que la porte se trouve au centre dell'ouverture.

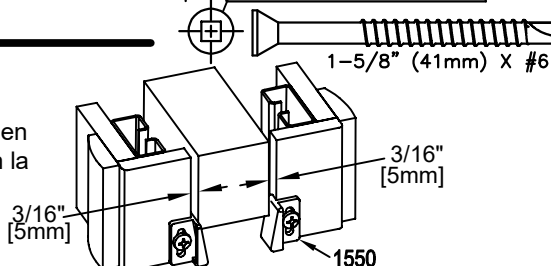

**CUTTING INSTRUCTIONS
POCKET DOOR FRAME HEADER**

2/6" [762mm] and 3/0" [914mm] Pocket Door Frames are marked for cutting to shorter standard door widths.

**INSTRUCCIONES DE CORTE
CABECERA DEL MARCO PARA
PUERTAS CORREDIZAS**

Los marcos de las Puertas Corredizas de 762mm y 914mm estan marcados para ser cortados a anchuras menores la cuales corresponden a puertas estandares.

**INSTRUCTIONS DE COUPE
LINTEAU POUR PORTE ESCAMOTABLE**

Les cadres de porte de 762mm et 914mm sont marquées pour être coupés à des largeurs de portes standard plus courtes.

- 1** Remove Adjustable End Bracket.
Remueva el soporte ajustable del extremo.
Démontez le crochet d'extrémité ajustable.
- 2** At desired door size marking, cut wood header only.
En la marca que corresponde al tamaño deseado de la puerta, corte solamente la madera de la cabecera.
A la marque correspondant à la dimension de porte désirée, découpez seulement le guide en bois.
- 3** Turn header over and cut track 1-3/8" [35mm] shorter than header.
Voltee la cabecera y corte el riel 35mm mas corto que la cabecera.
Retournez le guide et coupez la glissière 35mm plus court que le guide.
- 4** Replace Adjustable End Bracket on new cut end of header.
Reemplace el Soporte Ajustable del Extremo en el nuevo extremo de la cabecera recién cortado.
Remontez le crochet d'extrémité ajustable sur la nouvelle extrémité coupée du guide.
- 5** Turn Header on side and cut Header Trim Board ONLY at proper mark. Remove cut off end and discard.
Voltee la cabecera en un costado y corte solamente la Tabla del Contramarco del Encabezador donde esta la marca apropiada. Remueva el extremo que se corta y bótelo.
Retournez le guide de coté et découpez SEULEMENT la bague de guide à la marque désirée. Enlevez et jetez l'extrémité coupée.
- 6** Turn Header and cut other side.
Voltee la cabecera y corte el otro costado.
Retournez le guide et découpez l'autre coté.

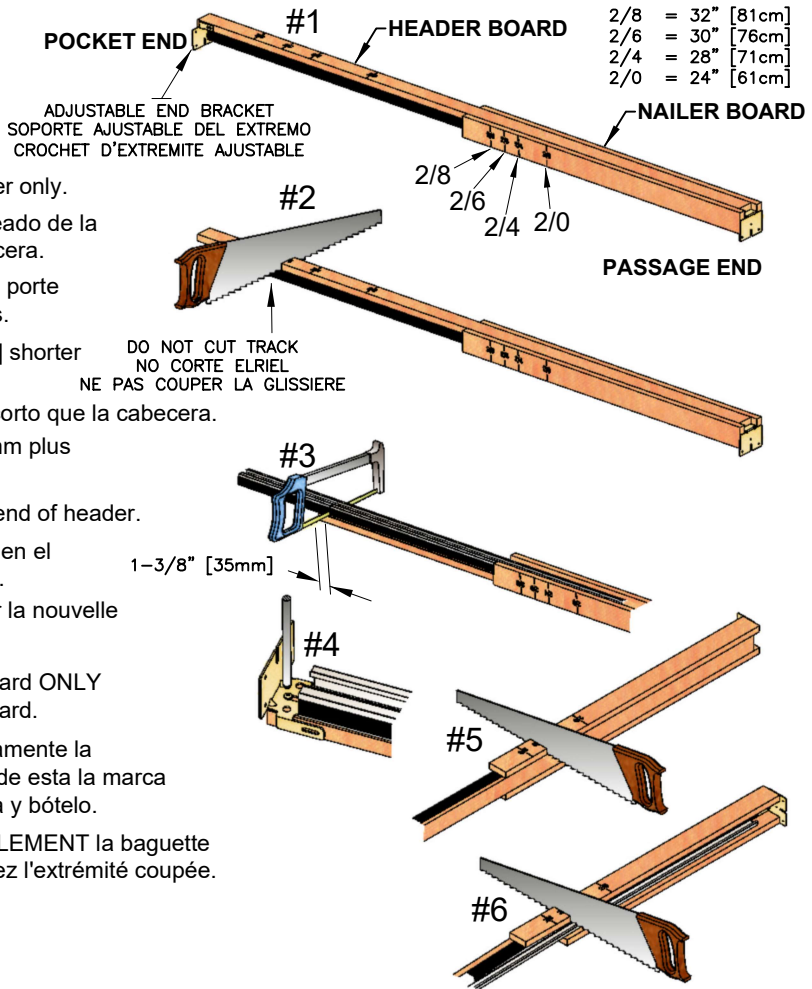

Cutting Instructions for unmarked or non-standard door widths, use QR code.

Frame Height Cutdown: Cut from bottom of metal split studs only (end without holes).
Cut difference in door height: Ex. 80" frame, 79" door height, cut 1" from bottom of each split stud.



**OPTIONAL
ACCESSORIES**

30 #30 PULL, CLENCH, JALE AVAILABLE IN 3 FINISHES / DISPONIBLE EN 3 ACABADOS / DISPONIBLE EN 3 FINITIONS

1555 CONVERGING DOOR KIT / CONJUNTO PIEZAS PARA PUERTA CONVERGENTE / ASSEMBLAGE CONVERGENT DE PORTE

40 1-3/8" X 3" RECTANGULAR PULL / TIRADOR RECTANGULAR DE 35mm X 76mm / TIRETTE RECTANGULAIRE DE 35mm X 76mm

35 1-3/8" X 3" RECTANGULAR PULL / TIRADOR RECTANGULAR DE 35mm X 76mm / TIRETTE RECTANGULAIRE DE 35mm X 76mm

21 2-1/8" DIAMETER PULL / TIRADOR DE DIA. DE 54mm / TIRETTE CIRCULAIRE DE 54mm

134 (1-3/4" 45mm)

1521 (1-3/8" 35mm) PRIVACY LOCK / CERRADURA PRIVADA / SERRURE PRIVEE

2041 HIDDEN GUIDE SET / JUEGO DE GUIA OCULTA / ENSEMBLE DE GUIDAGE CACHE

1515-PLY PLYWOOD CLIP SET / JUEGO DE PINZAS PARA MADERA TERCIADA / ENSEMBLE D'ATTACHES DE CONTRAPLAQUE

1510/1511 JAMB KIT (FINGER JOINT AND CLEAR PINE) / 1510/1511 CONJUNTO DE PIEZAS DE LA JAMBA (UNION DE ALETAS Y PINO CLARO) / 1510/1511 ASSEMBLAGE DU MONTANT (ASSEMBLAGE PAR ENCASTREMENT ET PIN SANS DEFAULTS)

150 EDGE PULL / TRADOR DE BORDE / TIRETTE LATERALE



www.johnsonhardware.com

INSTRUCTIONS

CUTTING INSTRUCTIONS POCKET DOOR FRAME HEADER

CUTTING INSTRUCTIONS POCKET DOOR FRAME HEADER

2/6" [762mm] and 3/0" [914mm] Pocket Door Frames are marked for cutting to shorter standard door widths.

INSTRUCCIONES DE CORTE CABECERA DEL MARCO PARA PUERTAS CORREDIZAS

Los marcos de las Puertas Corredizas de 762mm y 914mm estan marcados para ser cortados a anchuras menores la cuales corresponden a puertas estandares.

INSTRUCTIONS DE COUPE LINTEAU POUR PORTE ESCAMOTABLE

Les cadres de porte de 762mm et 914mm sont marquées pour être coupés à des largeurs de portes standard plus courtes.

- 1 Remove Adjustable End Bracket.
Remueva el soporte ajustable del extremo.
Démontez le crochet d'extrémité ajustable.

ADJUSTABLE END BRACKET
SOPORTE AJUSTABLE DEL EXTREMO
CROCHET D'EXTREMITE AJUSTABLE

2/8 = 32" [81cm]
2/6 = 30" [76cm]
2/4 = 28" [71cm]
2/0 = 24" [61cm]

- 2 At desired door size marking, cut wood header only.
En la marca que corresponde al tamaño deseado de la puerta, corte solamente la madera de la cabecera.
A la marque correspondant à la dimension de porte désirée, découpez seulement le guide en bois.

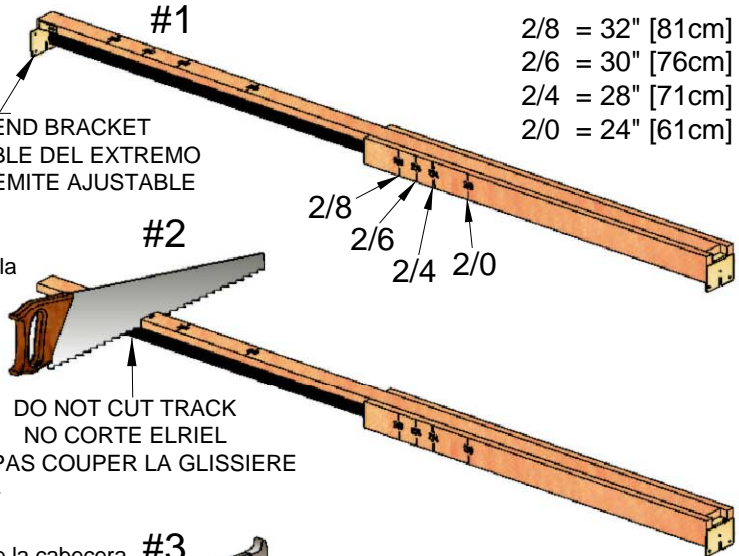

- 3 Turn header over and cut track 1-3/8" [35mm] shorter than header.
Voltee la cabecera y corte el riel 35mm mas corto que la cabecera.
Retournez le guide et coupez la glissière 35mm plus court que le guide.

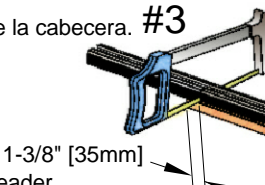

- 4 Replace Adjustable End Bracket on new cut end of header.
Reemplace el Soporte Ajustable del Extremo en el nuevo extremo de la cabecera recién cortado.
Remontez le crochet d'extrémité ajustable sur la nouvelle extrémité coupée du guide.

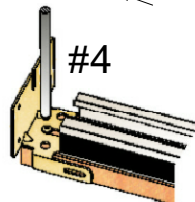

- 5 Turn Header on side and cut Header Trim Board ONLY at proper mark. Remove cut off end and discard.
Voltee la cabecera en un costado y corte solamente la Tabla del Contramarco del Encabezador donde esta la marca apropiada. Remueva el extremo que se corta y bótelo.
Retournez le guide de coté et découpez SEULEMENT la baguette du guide à la marque désirée. Enlevez et jetez l'extrémité coupée.

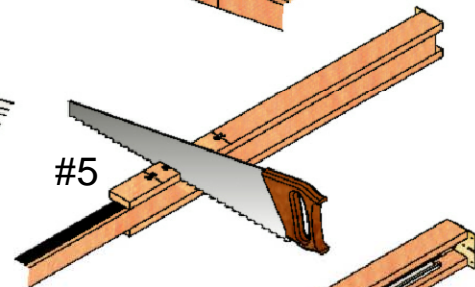

- 6 Turn Header and cut other side.
Voltee la cabecera y corte el otro costado.
Retournez le guide et découpez l'autre coté.

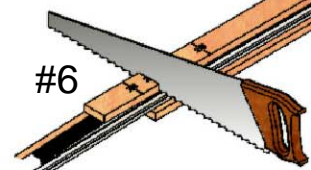

Cutting header for other than standard door width: Measure door width and multiply by 2. Add 1" (25mm). Mark header and cut (Step #2). Cut track (Step #3). Measure door width. Add 1" (25mm). Mark header Trim board and cut (Step #5 & #6).

Para cortar la cabecera para puertas que no sean de un ancho estandar: Mida el ancho de la puerta y multipliquelo por 2. Súmele 25mm. Marque la cabecera y córtelo (Paso #2). Corte el riel (Paso #3). Mida el ancho de la puerta. Súmele 25mm. Marque la guía de la tabla del contramarco de la cabecera y córtelo (pasos #5 & #6).

Découpage de la porte à une dimension non standard: Mesurez la largeur de la porte et multipliez par 2. Ajoutez 25mm. Marquez le guide et découpez. (étape #2). Découpez la glissière (étape #3). Mesurez la largeur de la porte. Ajoutez 25mm. Marquez la baguette du guide et découpez (étape #5 & #6).

INSTRUCTIONS

Cutting Instructions for unmarked frames or non standard door widths

1 Mark Header and Side Nailers for door size.

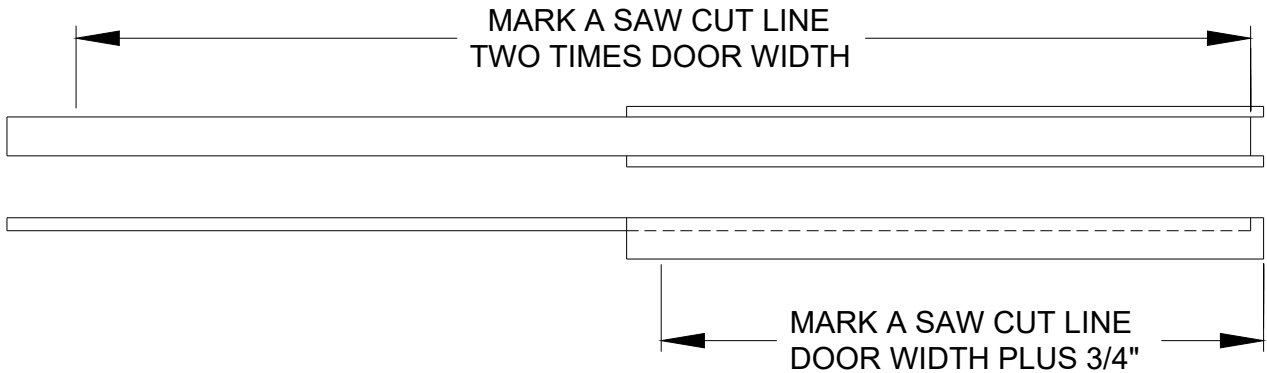

2 Remove Adjustable End Bracket.

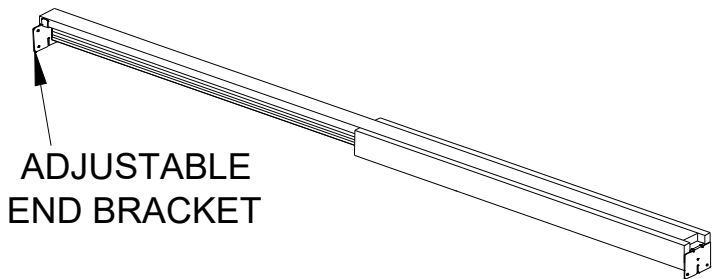

5 Replace Adjustable End Bracket on new cut end of header.

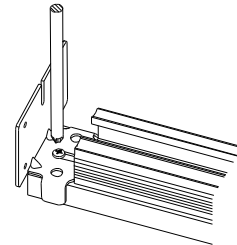

3 Cut through WOOD part of header only at mark.

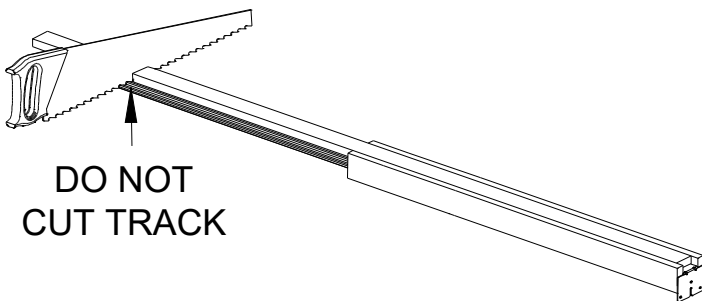

6 Turn Header on side and cut Side Nailer Trim Board ONLY at mark. Remove cut off end and discard.

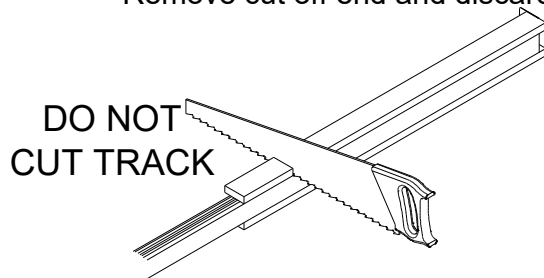

4 Turn Header over and cut Track 1-3/8" shorter than wood Header.

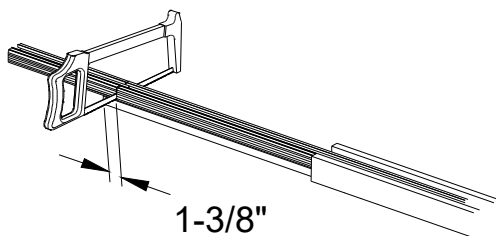

7 Repeat step #6 on the other Side Nailer Trim Board.

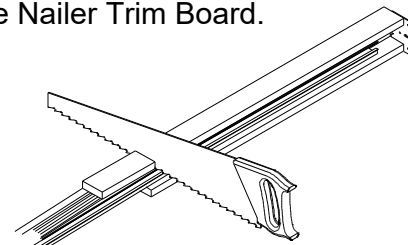



www.johnsonhardware.com

INSTRUCTIONS

SPECIAL APPLICATIONS

INTERSECTING WALLS

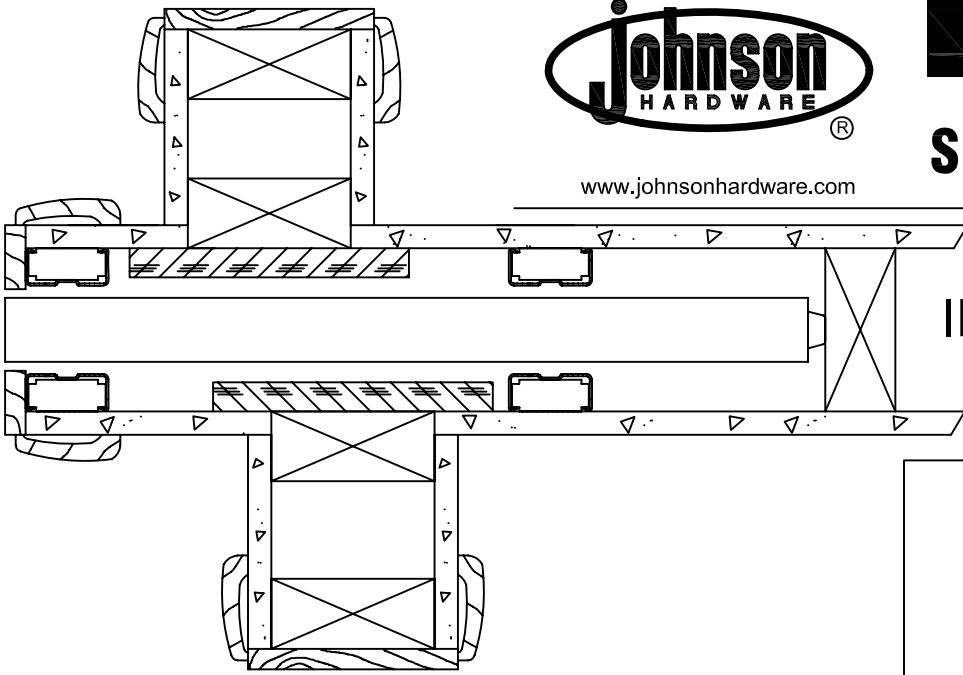

DOOR SWEEP

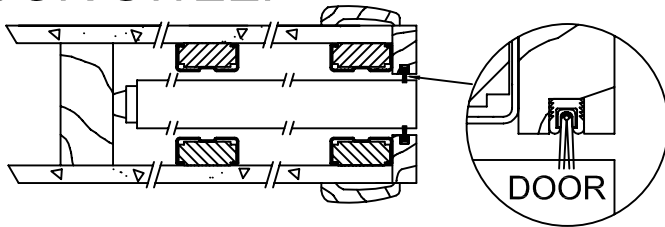

● PEMKO 5025_p

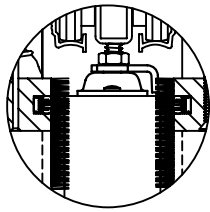

3/16" (5mm)

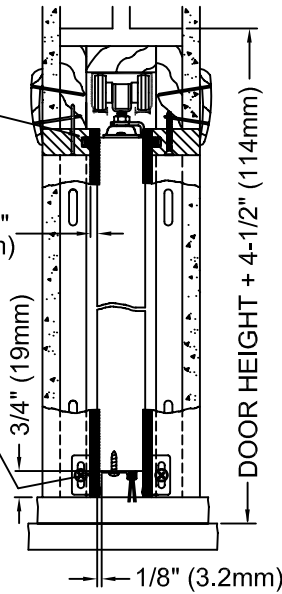

DOOR HEIGHT + 4-1/2" (114mm)

1/8" (3.2mm)

No. 6 x 5/8" PHSMS, Phillips (Factory Provided)

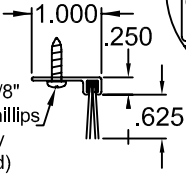

● PEMKO 90062_P

TRANSOM

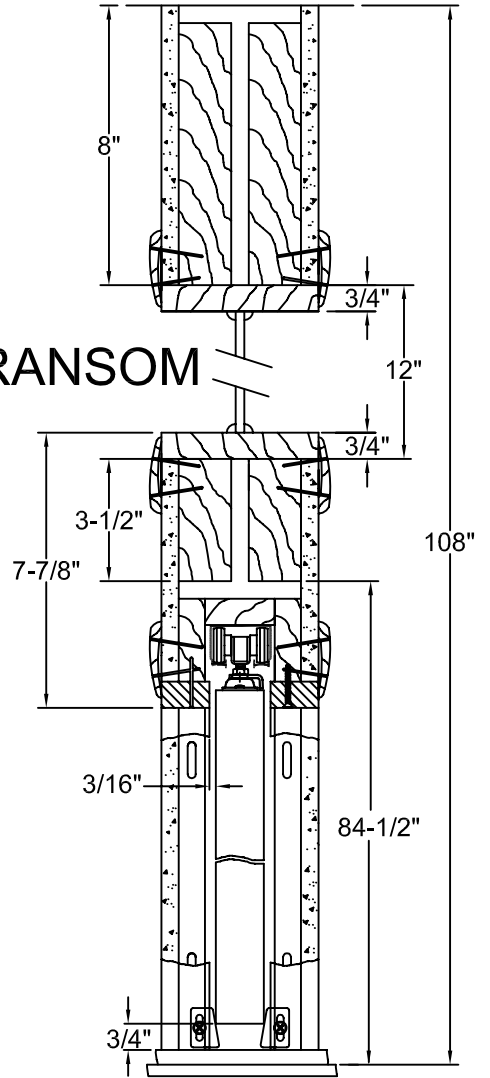

BI - PARTING POCKET DOOR

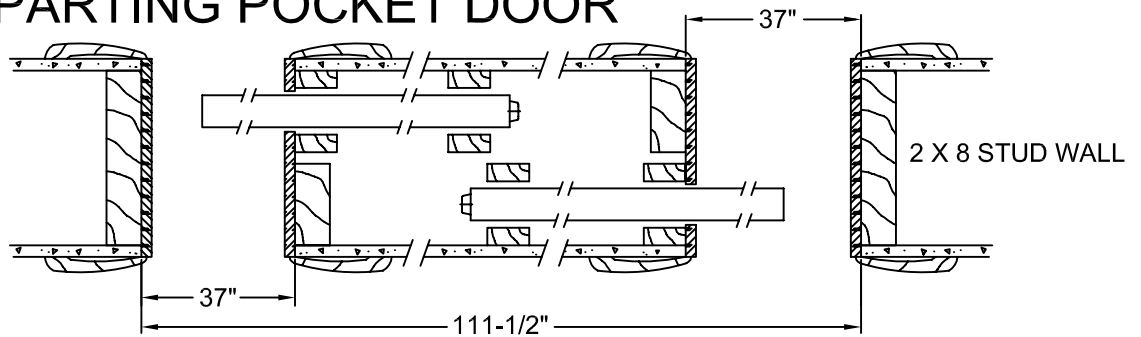

INSTRUCTIONS

FOR USE WITH
100PD/1500/1560/1562
POCKET DOOR HARDWARE

1060 SOFT CLOSE POCKET

MAXIMUM DOOR WEIGHT
165 lbs. (75kg)

100PD/1500/1560/1562 Pocket Door Instructions:

Instructions are for installing the 1060 Soft Close in a Pocket Door Frame using JOHNSON 100 Series Track.
Minimum Door Thickness 1" (25mm)

28" [711MM] Minimum Door Width for bi-directional soft door operation.

20" [508mm] Minimum Door Width for single direction soft door operation.

Single direction soft door operation requires additional 1125 Door Hanger NOT INCLUDED.

Following steps are for soft close.

- 1 IF FRAME is already installed, disconnect Hangers from Door Plates and remove door. Remove both Hangers from track-Remove Door Plates from door.
- 2 ATTACH 1121 Door Plates 2-3/4" (70mm) from door edge.
- 3 INSERT 1125 Ball Bearing Hanger Wheel assembly into Track.
- 4 Engage Soft Close Dampener by pushing Dampener trigger toward 3 Wheel Roller. This step is very important. DAMPENERS MUST BE ENGAGED or soft close will not work, 1060 Soft Close Dampener may be DAMAGED if installed incorrectly. Door will have to be removed and installation of 1060 will have to begin again.

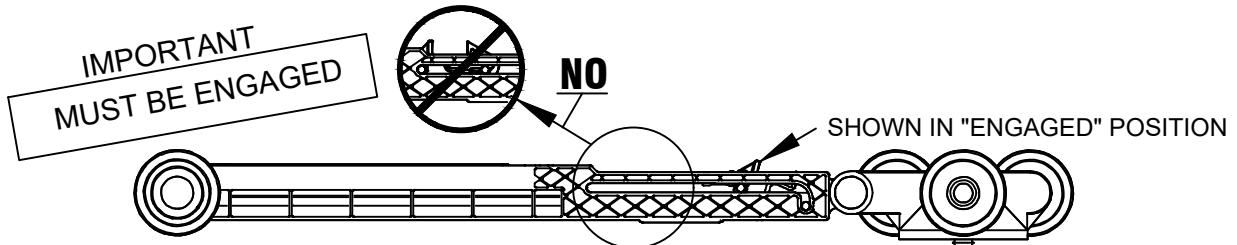
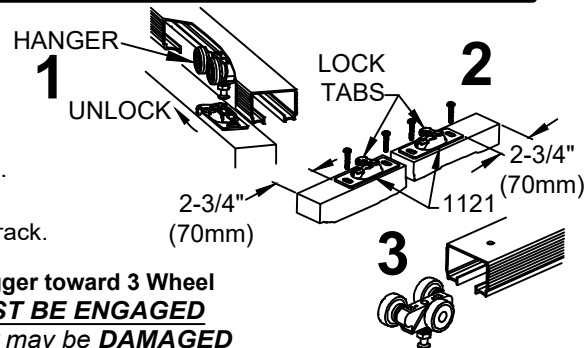

- 5 INSERT 1060 into Track. (Idle wheels first).

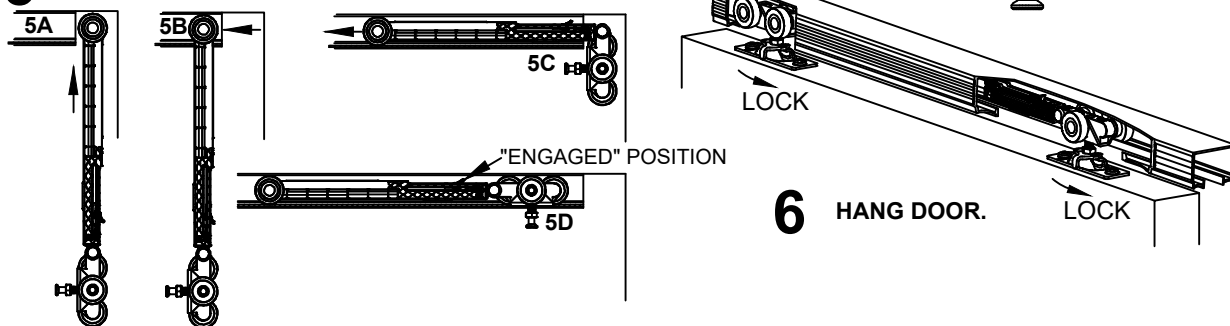

- 7 SLIDE door away from end of track (check to make sure all track screws are flat against track and does not interfere with movement of dampener hanger) and install 1060 Actuator Arm into track, with back of Actuator Arm 2-1/4" (57mm) from Jamb. **HAND TIGHTEN** (do not use power drill) Actuator Arm on track. Check to make sure Arm stayed straight in track. Slowly close door, checking to make sure door touches Jamb, if not. Slide door away from Jamb and readjust Actuator Arm. Slowly close door again, checking to make sure soft close is working properly. Once confirmed, begin using door normally.

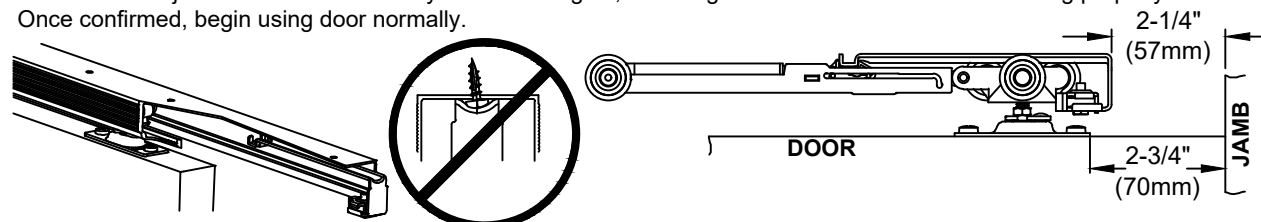

Following steps are for soft open. Skip steps 1-3 if new installation.

- 1** IF FRAME is already installed, disconnect Hangers from Door Plates and remove door. Remove both Hangers from track-Remove Door Plates from door.
- 2** CUT ACCESS HOLE by measuring door width and door height, then on pocket wall, measure over door width minus 2" (51mm) and door height minus 2" (51mm). Then from that mark, measure down 8" (203mm) and over toward opening 8" (203mm). Cut square in wall to access track.

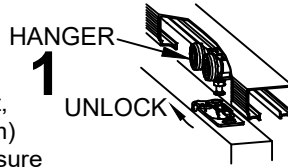

- 3** CHECK to make sure all track screws are flat against track. DISASSEMBLE ACTUATOR ARM, (with backside of arm facing pocket), insert arm, bumper and lock nut into track and reassemble. Slide assembly into pocket until backside of Actuator Arm is 2-1/4" (57mm) plus the finish Split Jamb thickness from the rough stud. **Example 2-1/4" (57mm) + 7/16" (11mm) Finish Jamb = 2-11/16" (68mm).** Hand tighten Actuator Arm (do not use power drill). Check to make sure Arm remains straight in track.

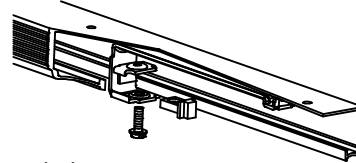

- 4** IF NEW INSTALLATION insert Actuator Arm as shown below.

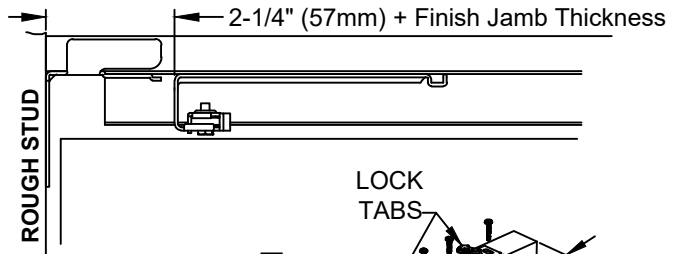
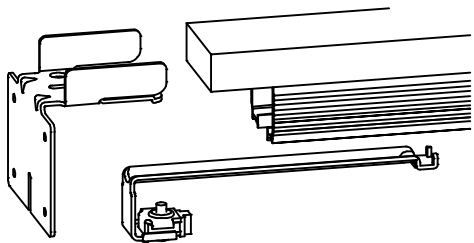

Remove Bracket, Install Actuator Arm, Reattach Bracket.

- 5** ATTACH 1121 Door Plates 2-3/4" (70mm) from door edge.
- 6** Engage Soft Close Dampener by pushing Dampener trigger toward 3 wheel roller. *This step is very important. DAMPENER MUST BE ENGAGED* or soft close will not work, 1060 Soft Close Dampener may be **DAMAGED** if installed incorrectly. Door will have to be removed and installation of 1060 will have to begin again.

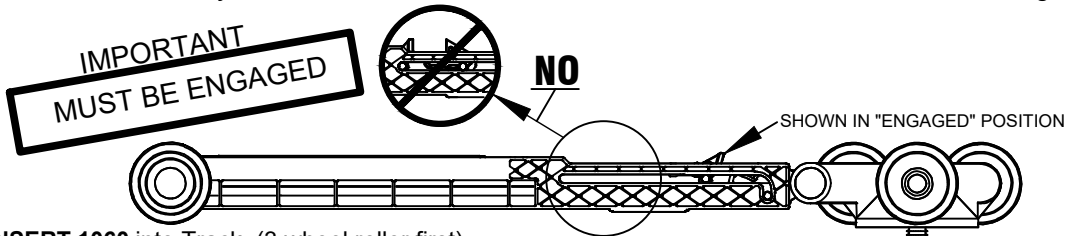

- 7** INSERT 1060 into Track. (3 wheel roller first).

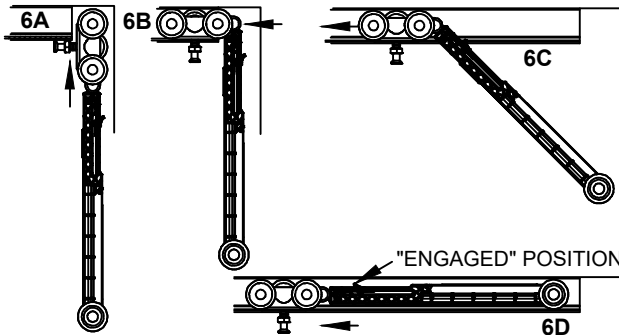

- 8** INSERT 1125 Ball Bearing Hanger Wheel assembly into Track.

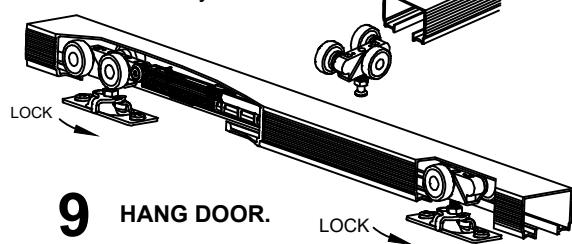

- 9** HANG DOOR.

- 10** SLOWLY slide door into pocket, checking to make sure door opens flush with Split Jamb, if not, slide door out of pocket and readjust Actuator Arm. Slowly open door again, checking to make sure soft close is working properly. Once confirmed, begin using door normally. When installing 1513 bumper on back of door make sure it bumps rough stud at same time as dampener hanger bumps Actuator bumper.

- 11** PATCH the wall.



www.johnsonhardware.com

INSTRUCTIONS

1060 SOFT CLOSE

Pocket Door Soft Close Installation Layout 1060 Actuator Location / Minimum Door Width

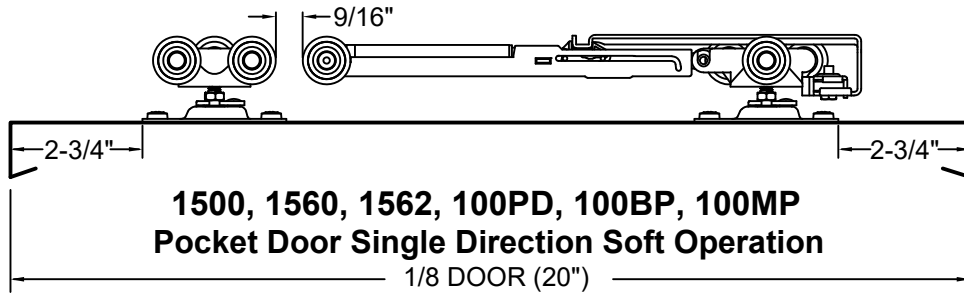
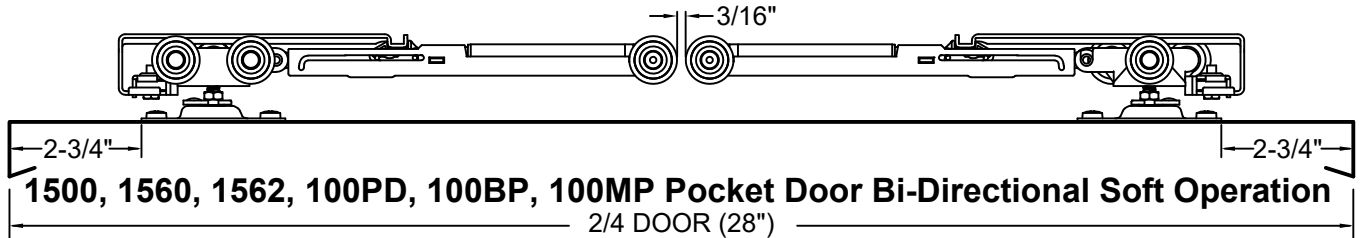

ByPass Door Soft Close Installation Layout 1060 Actuator Location / Minimum Door Width

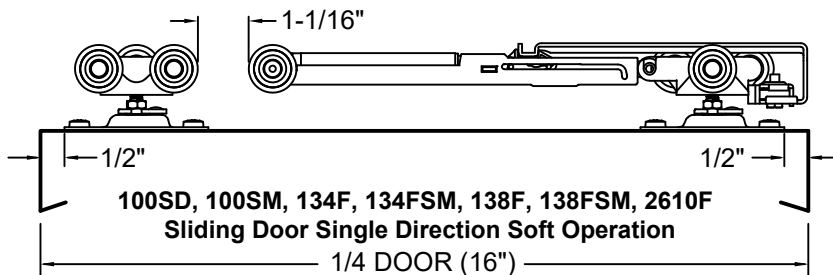
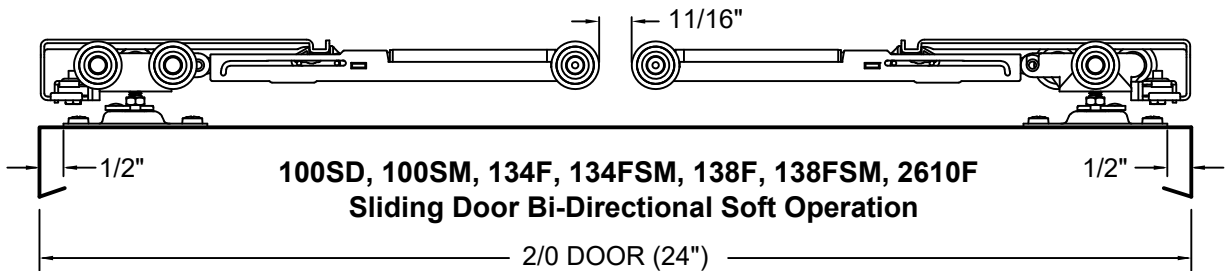



www.johnsonhardware.com

INSTRUCTIONS

1555 CONVERGING DOOR KIT

FOR USE WITH TWO JOHNSON
1500, 1560, 2511, 2710 OR 2711 SERIES
POCKET DOOR FRAMES

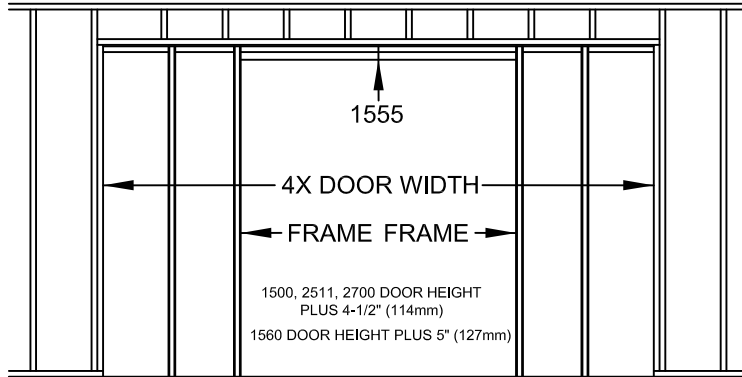

FOR 1500, 1560 AND 2511 SERIES:

ROUGH OPENING WIDTH IS FOUR TIMES DOOR WIDTH

★ **FOR 2710/2711 SERIES:**

ROUGH OPENING IS FOUR TIMES DOOR WIDTH PLUS 1-1/2" (38mm)

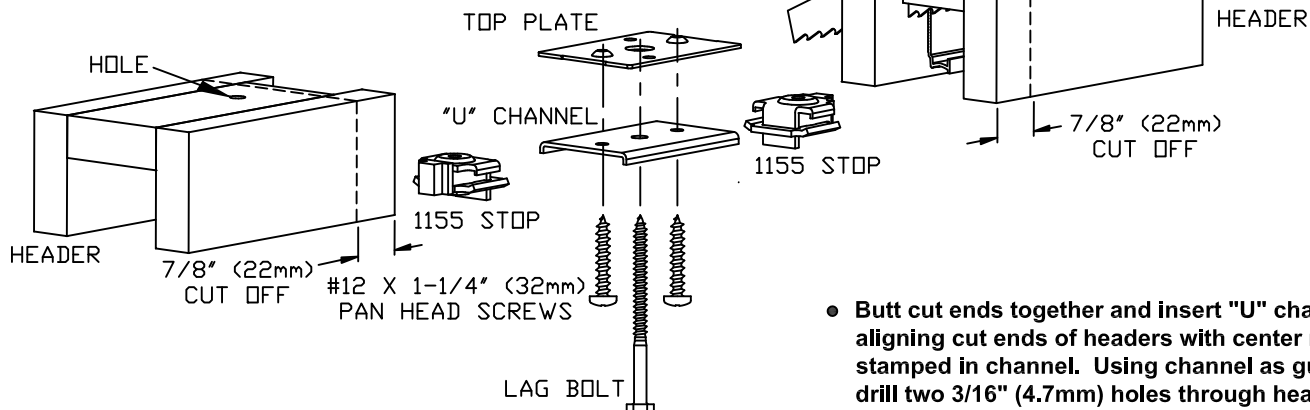
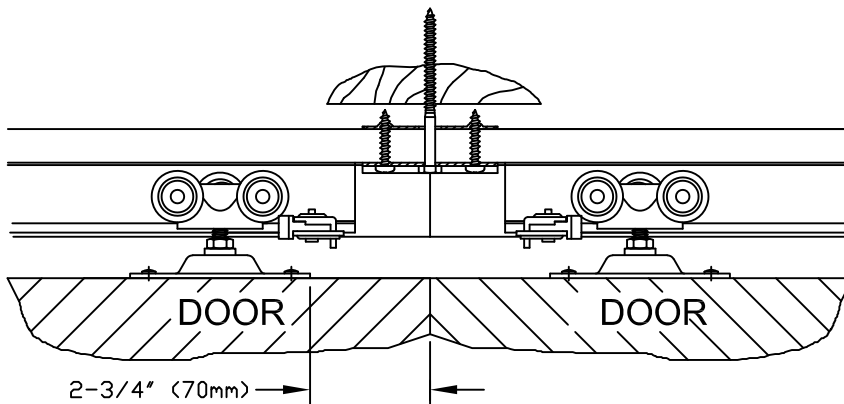
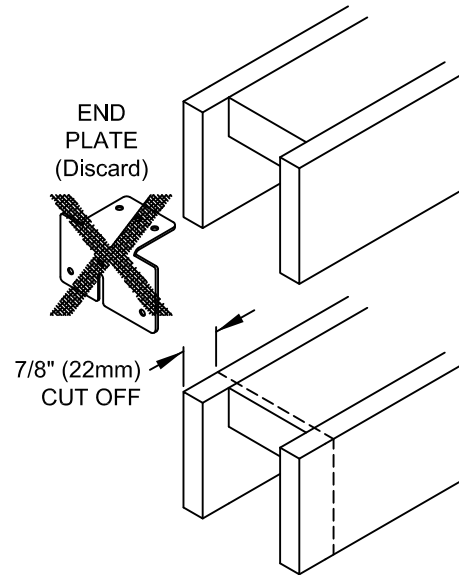

- Butt cut ends together and insert "U" channel, aligning cut ends of headers with center mark stamped in channel. Using channel as guide, drill two 3/16" (4.7mm) holes through headers at outer channel holes. Insert screws through these holes and into top plate on top of header. Tighten, forming a one-piece header.
- Drill a 1/4" (6.3mm) hole at channel center where header ends meet to enable the lag screw to be fastened into rough header for increased center support.
- Insert stops into track and leave loose until doors are hung, then tighten. Proceed with regular frame assembly instructions.

1555PPK3 CONVERGING DOOR KIT

For joining two Johnson 1500, 1560, 2511, 2710 or 2711 Pocket Door Frames

- Remove and discard end plates from "door opening" end of each header.
- Cut 7/8" (22mm) from length of each header (wood part only) where discarded end plates had been located. Cut ends square to keep header straight when joined.

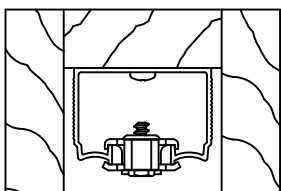



www.johnsonhardware.com

INSTRUCTIONS

2041 PDF BOTTOM GUIDE SET

FOR USE WITH JOHNSON
2000, 2060, 1500, 1560, 2511
POCKET DOOR FRAMES

1 ROUT 5/16" (8mm) X 1" (25mm) groove in bottom of Door.

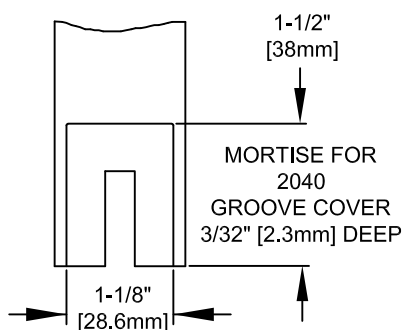
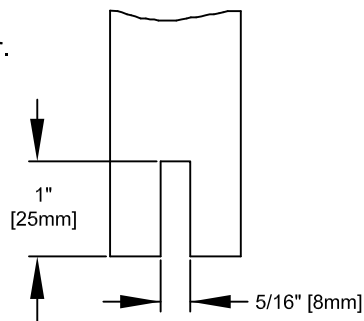

2 MORTISE end of Door's front edge for 2040 Groove Cover. 1-1/8" (28.6mm) wide X 1-1/2" (38mm) high X 3/32" (2.3mm) deep.

3 ATTACH 2041 Guide to floor bracket located at edge of front pocket opening. Use tall guide if Frame Floor Bracket is attached to the sub-floor or the short guide when it is attached to finished floor.

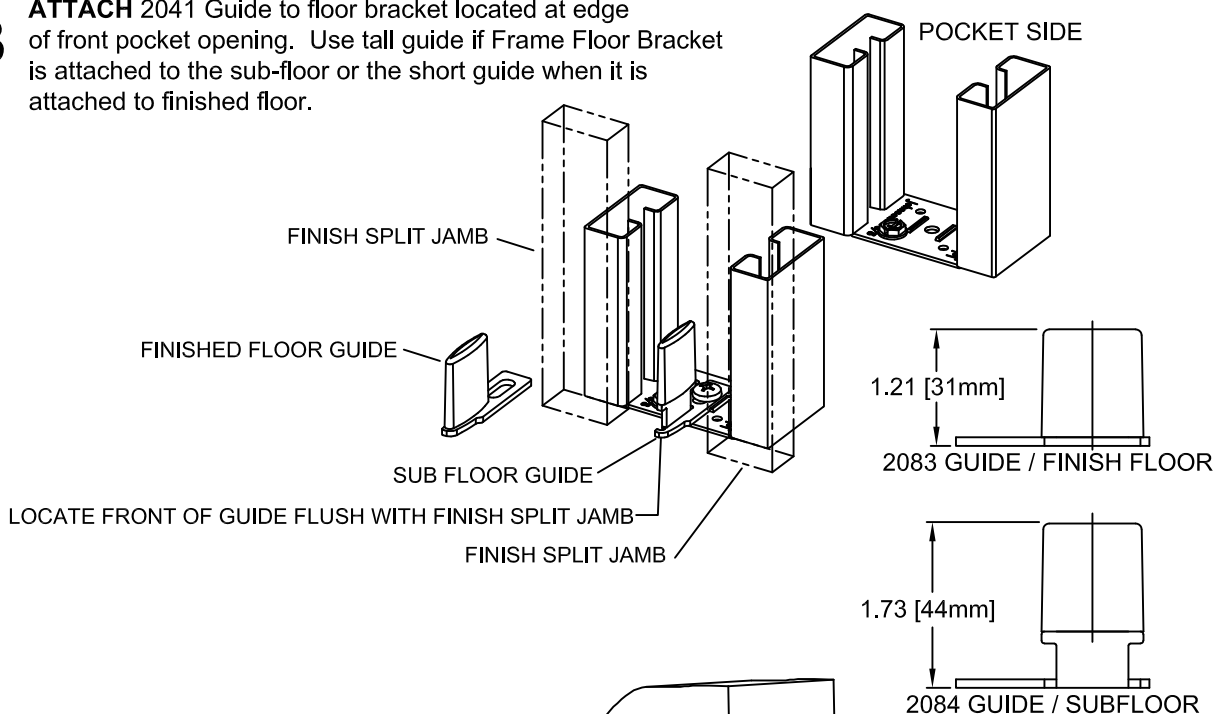

4 ATTACH 2040 Rout Groove Cover in mortise area.

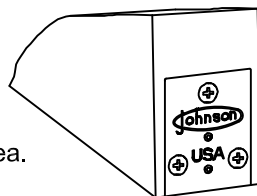

PASSAGE SIDE VIEW

CONVERGING CORNER POCKET

USE APPROPRIATE SIZE LAG BOLT TO SECURE THRU JOHNSON HEADERS
TO ROUGH POCKET DOOR OPENING HEADERS

USE TWO #12 PAN HEAD SCREW TO FASTEN
BRACKET TO JOHNSON POCKET DOOR HEADER

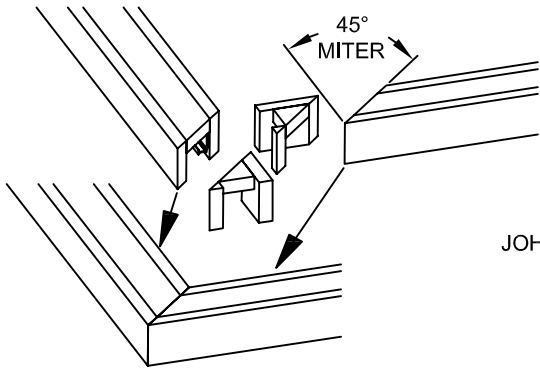

MITER JOHNSON POCKET DOOR HEADER ON 45°

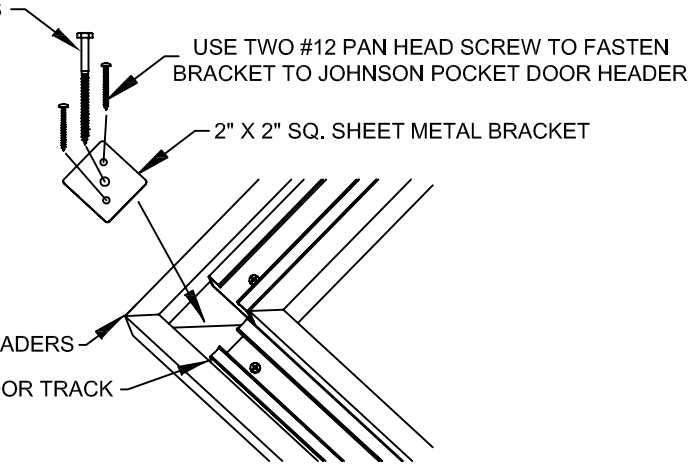

ATTACHING JOHNSON POCKET DOOR HEADERS TO ROUGH OPENING

