

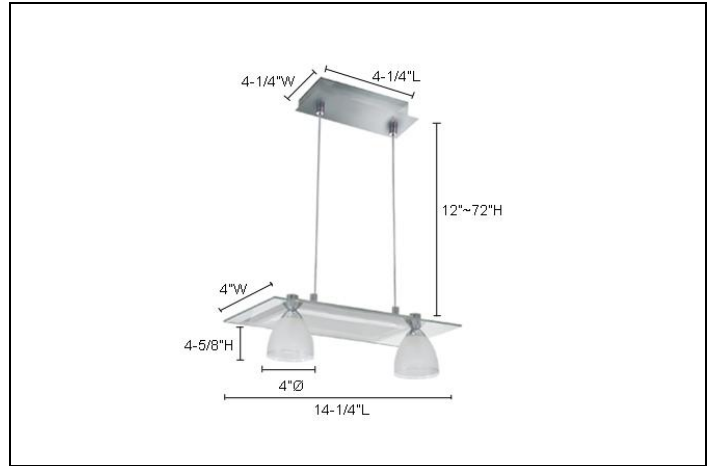

# PD 304-2 • SLANTUS

ENVISAGE  
PENDANT SERIES

Type	
Project	
Catalog No.	



## CATALOG INFORMATION

### MODEL

PD 304-2

## DESCRIPTION

- 2- Light Adjustable Pendant
- The elegant SLANTUS – Series 304 includes a 2- and 4-light Pendant, and a 1- and 2-light Wall Sconce. The frosted glass in the wall sconce is a cut at an angle with a clear band around the edges making this modern version of a classic design not only look better, but increasing lighting not only look better, but increasing lighting efficiency on the walls of a space.
- Transformer: Built-in Electronic
- Glass Dimensions: 14-1/4”L x 4”W x 4-5/8”H
- Canopy Dimensions: 4-1/4”L x 4-1/4”W
- Height Adjustment: 12” ~ 72”
- Canopy Finish: SN – Satin Nickel

### LAMP:

(2) Xenon Bi-Pin 12V 35W (included).

## SERIES 304 – SLANTUS



WS 304-1



WS 304-2



PD 304-4