

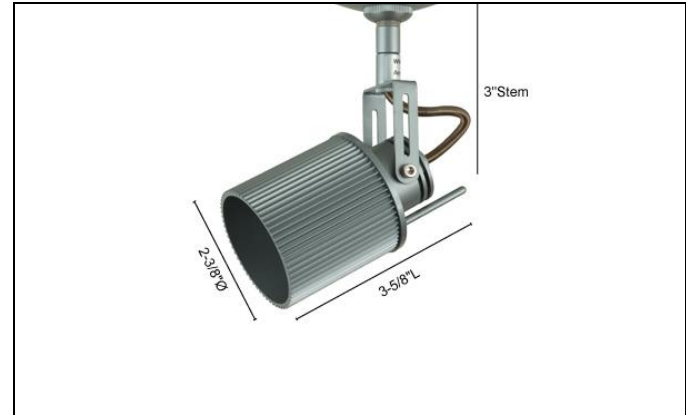

QASL 192 X3 30 • PATRICK

LOW VOLTAGE MONORAIL
LED QUICK ADAPT SPOTS

Type	
Project	
Catalog No.	



CATALOG INFORMATION

MODEL	# LED's	MAX WATT	MAX LUMENS	CCT	FINISH
QASL 192 X3 30 PATRICK	3 x 1 W	4.5 W	270 Lm	30 – 3000K	SN – Satin Nickel

Ordering Instructions **MODEL** - **FINISH**
 Example: -

DESCRIPTION

- LED Quick Adapter Jack, integral driver and LED lamping.
- 350° horizontal and 320° of vertical aiming
- Dimensions: 3-5/8”L x 2-3/8”Ø x 3”H stem

COMPATIBLE POWER SUPPLIES

LED Power Supplies - 12V DC

Part Number				Description	
<input type="text" value="DL"/>	-	<input type="text" value="PS"/>	-	<input type="text" value="20"/> / <input type="text" value="12"/> - <input type="text" value="JB"/>	20 Watts
				<input type="text" value="60"/>	60 Watts
				<input type="text" value="150"/>	150 Watts
				<input type="text" value="320"/>	320 Watts
				<input type="text" value="120"/>	2 x 60 Watts
				<input type="text" value="180"/>	3 x 60 Watts

COMPATIBLE SYSTEMS



MONORAIL SYSTEM

The Monorail Fixture Adapter (MA-FA) provides the connection between Quick Adapt Pendant to the Monorail.



MONOPOINT

For remote installations only. Select from either QAC-1C-RT or QAC-1C-RTH