



ADJUSTABLE-SHELF

Specification:

1. Material: MDF + Plywood + Birch
2. Finish & Inset: See Table
3. Slides: USE58-300-18 + USCLIP2ND-4W( 2 Set )
4. Hinge: 700.0537.25 + 600.1234.05 ( 4 Set )  
700.0536.25 + 600.1234.05 ( 2 Set )
- 5 Shelf Supports: 1707BN ( 8 PCS )
6. The tolerance is +/- 1/8"

Item number	Finish	Inset
VN2PER-36-BK-NT	Black	PC
VN2PER-36-BL-NT	Blue	SBZ
VN2PER-36-WH-NT	White	SBZ
VN2PER-36-GR-NT	Grey	MB

 <b>PROPRIETARY AND CONFIDENTIAL</b> THE INFORMATION CONTAINED IN THIS DRAWING IS THE SOLE PROPERTY OF HARDWARE RESOURCES INC. ANY REPRODUCTION IN PART OR AS A WHOLE WITHOUT THE WRITTEN PERMISSION OF HARDWARE RESOURCES INC. IS PROHIBITED. DO NOT SCALE DRAWING	ITEM#: VN2PER-36	MATERIAL:
	FINISH:	WEIGHT: 9
	PROJECTION 	
	TOLERANCE UNLESS OTHERWISE SPECIFIED: X ±0.20 X.X ±0.10 X.XX ±0.05 ANGULAR: ±0.5°	UNITS: DRAWN BY: <b>Tony.Huang</b>
	SIZE: APPROVED BY:	DATE:
	SHEET: RELEASE LEVEL:	REVISION:

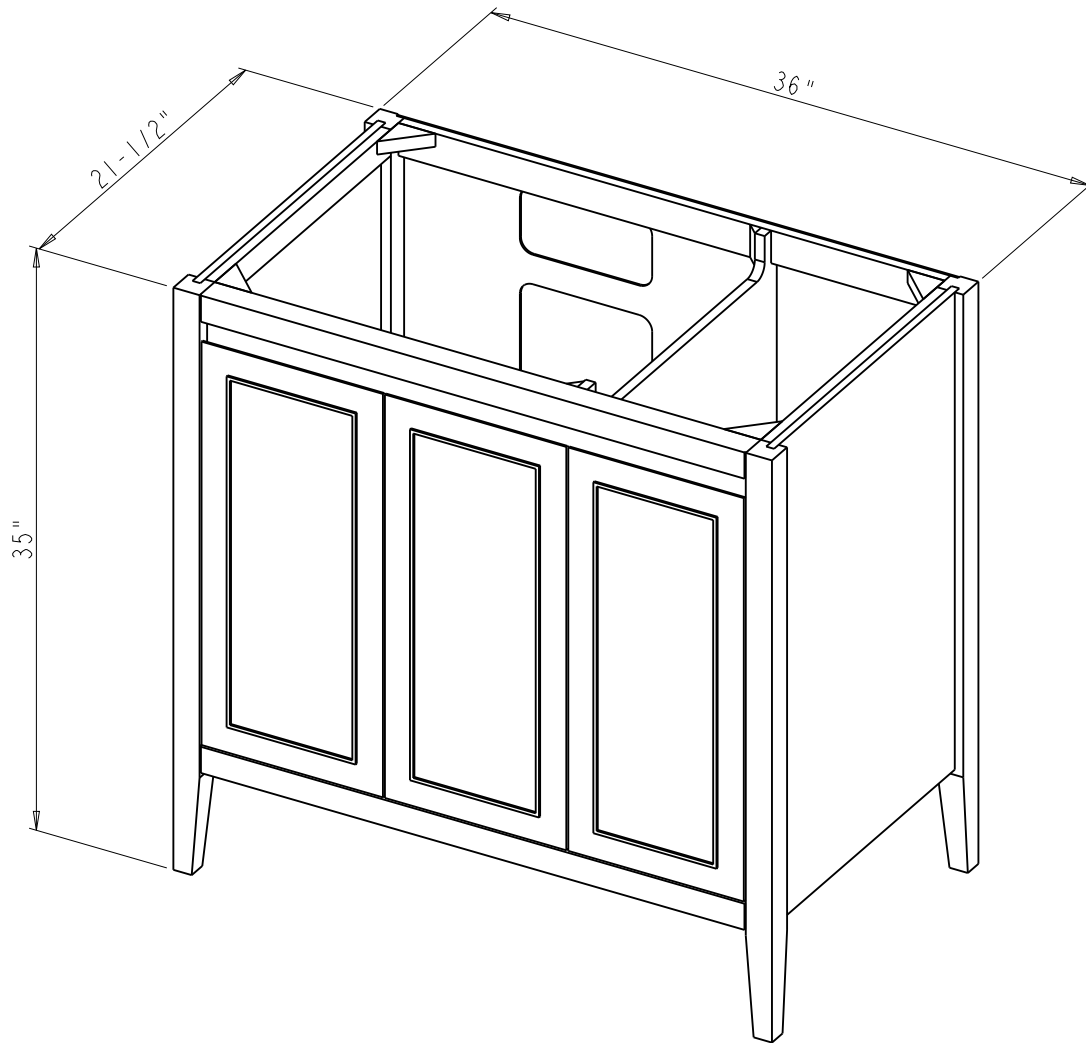

 <b>PROPRIETARY AND CONFIDENTIAL</b> THE INFORMATION CONTAINED IN THIS DRAWING IS THE SOLE PROPERTY OF HARDWARE RESOURCES INC. ANY REPRODUCTION IN PART OR AS A WHOLE WITHOUT THE WRITTEN PERMISSION OF HARDWARE RESOURCES INC. IS PROHIBITED.	ITEM#: VN2PER-36		MATERIAL:		
	FINISH:		WEIGHT:		
	TOLERANCE UNLESS OTHERWISE SPECIFIED: X ±0.20 X.X ±0.10 X.XX ±0.05 ANGULAR: ±0.5°		UNITS:	DRAWN BY: <i>Tony.Huang</i>	DATE: May-07-21
	DO NOT SCALE DRAWING		SIZE:	APPROVED BY:	DATE:
		SHEET:	RELEASE LEVEL:	REVISION:	



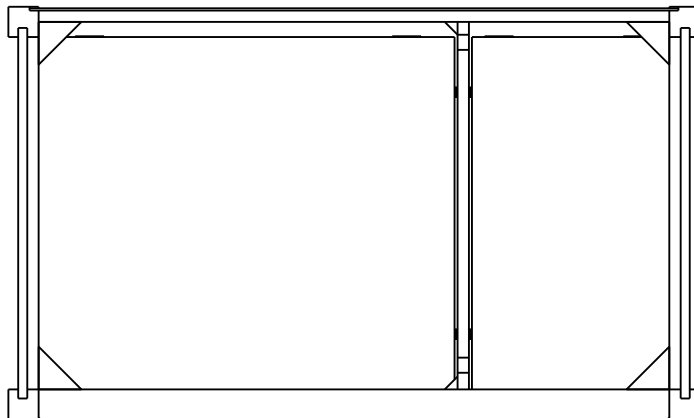
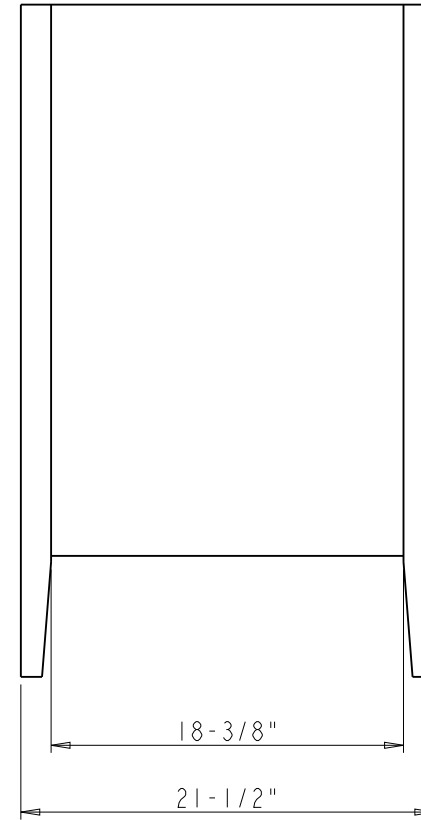
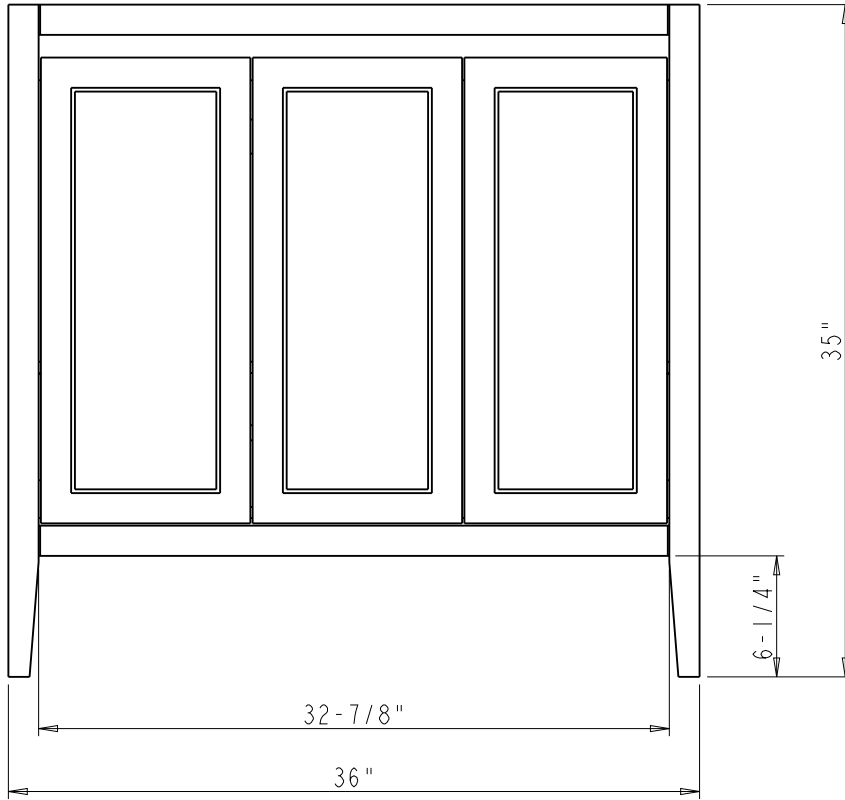

	ITEM#: VN2PER-36		MATERIAL:		
	FINISH:		WEIGHT: 9		
<p><b>PROPRIETARY AND CONFIDENTIAL</b></p> <p>THE INFORMATION CONTAINED IN THIS DRAWING IS THE SOLE PROPERTY OF HARDWARE RESOURCES INC. ANY REPRODUCTION IN PART OR AS A WHOLE WITHOUT THE WRITTEN PERMISSION OF HARDWARE RESOURCES INC. IS PROHIBITED.</p>	TOLERANCE UNLESS OTHERWISE SPECIFIED:		UNITS:		
	X ±0.20		DRAWN BY: <i>Tony.Huang</i>		
	X.X ±0.10		DATE: May-07-21		
	X.XX ±0.05		APPROVED BY:		
ANGULAR: ±0.5°		SHEET:		RELEASE LEVEL:	
DO NOT SCALE DRAWING		SHEET:		REVISION:	

