

ADJUSTABLE-SHELF

| Item number | Finish | Inset |
|-----------------|--------|-------|
| VN2PER-30-BK-NT | Black | PC |
| VN2PER-30-BL-NT | Blue | SBZ |
| VN2PER-30-WH-NT | White | SBZ |
| VN2PER-30-GR-NT | Grey | MB |

Specification:

1. Material: MDF + Plywood + Birch
2. Finish & Inset: See Table
3. Slides: USE58-300-18 + USCLIP2ND-4W(1 Set)
4. Hinge: 700.0537.25 + 600.1234.05 (4 Set)
5. Shelf Supports: 1707BN (4 PCS)
6. The tolerance is +/- 1/8"

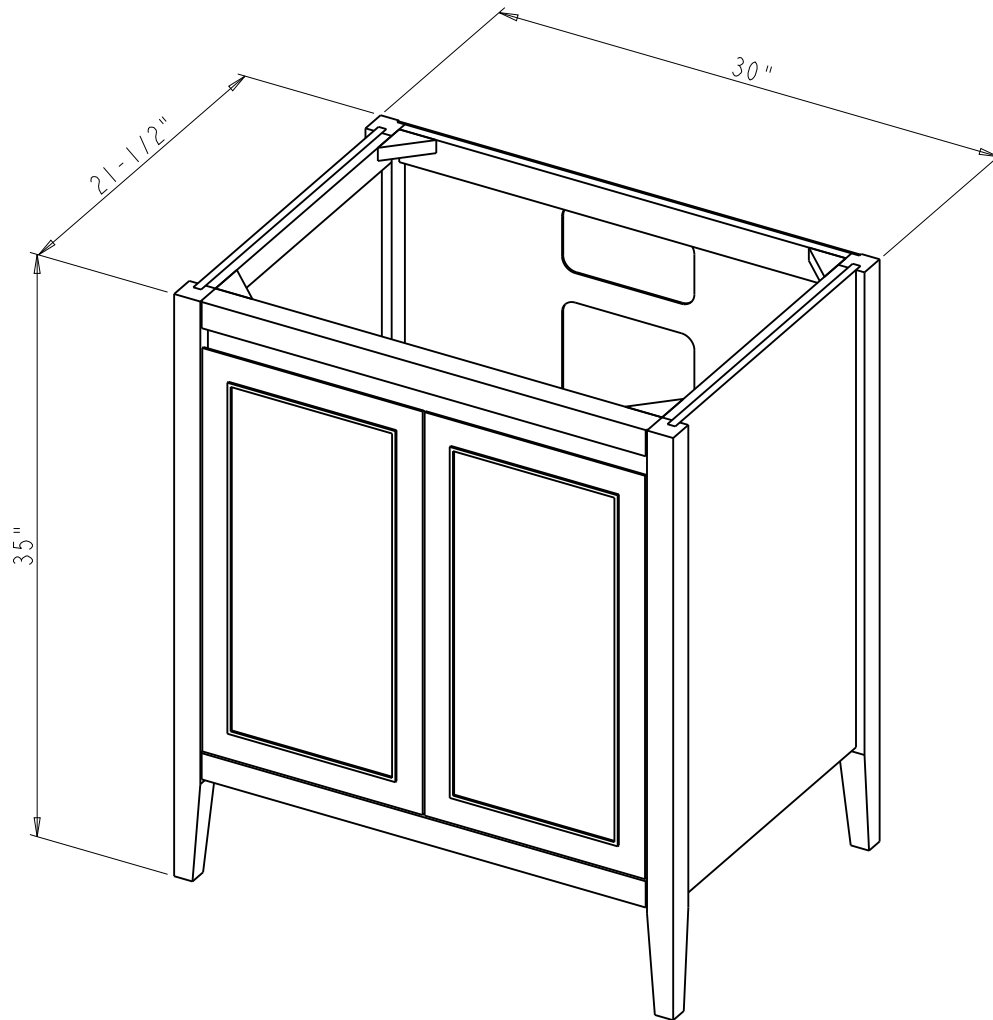

| | | | |
|---|---|-------------------------|-----------------|
|  <p>PROPRIETARY AND CONFIDENTIAL</p> <p>THE INFORMATION CONTAINED IN THIS DRAWING IS THE SOLE PROPERTY OF HARDWARE RESOURCES INC. ANY REPRODUCTION IN PART OR AS A WHOLE WITHOUT THE WRITTEN PERMISSION OF HARDWARE RESOURCES INC. IS PROHIBITED.</p> <p>DO NOT SCALE DRAWING</p> | ITEM#: VN2PER-30 | MATERIAL: | |
| | FINISH: | WEIGHT: | |
| | TOLERANCE UNLESS OTHERWISE SPECIFIED: X ±0.20 X.X ±0.10 X.XX ±0.05 ANGULAR: ±0.5° | UNITS: | DATE: Nov-22-21 |
| | SIZE: | APPROVED BY: Tony.Huang | DATE: |
| | SHEET: | REVISION: | |
| | RELEASE LEVEL: | | |



| | | | | | |
|---|---|--------|----------------|---------------------------|-----------------|
|  <p>PROPRIETARY AND CONFIDENTIAL</p> <p>THE INFORMATION CONTAINED IN THIS DRAWING IS THE SOLE PROPERTY OF HARDWARE RESOURCES INC. ANY REPRODUCTION IN PART OR AS A WHOLE WITHOUT THE WRITTEN PERMISSION OF HARDWARE RESOURCES INC. IS PROHIBITED.</p> | ITEM#: VN2PER-30 | | MATERIAL: | | |
| | FINISH: | | WEIGHT: 9 | | |
| | TOLERANCE UNLESS OTHERWISE SPECIFIED: X ±0.20 X.X ±0.10 X.XX ±0.05 ANGULAR: ±0.5° | | UNITS: | DRAWN BY: <i>Hugo.cai</i> | DATE: Apr-29-21 |
| | DO NOT SCALE DRAWING | | SIZE: | APPROVED BY: | DATE: |
| | | SHEET: | RELEASE LEVEL: | REVISION: | |

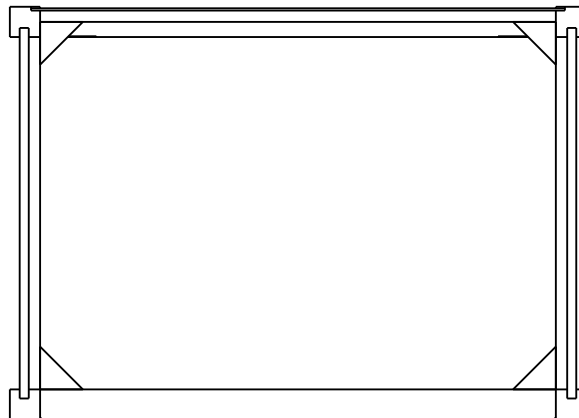
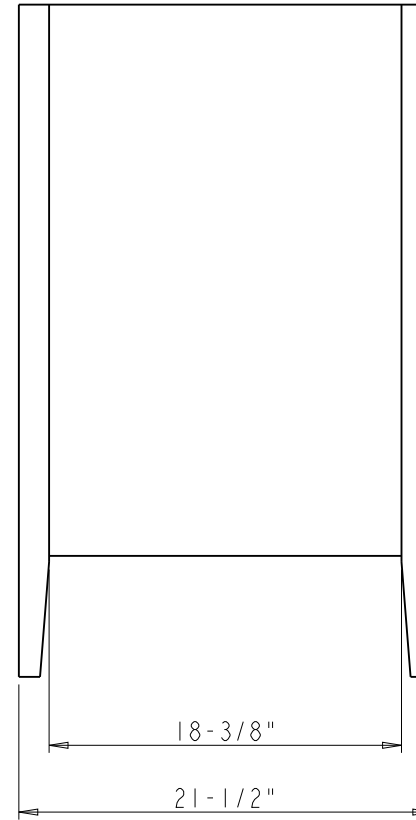
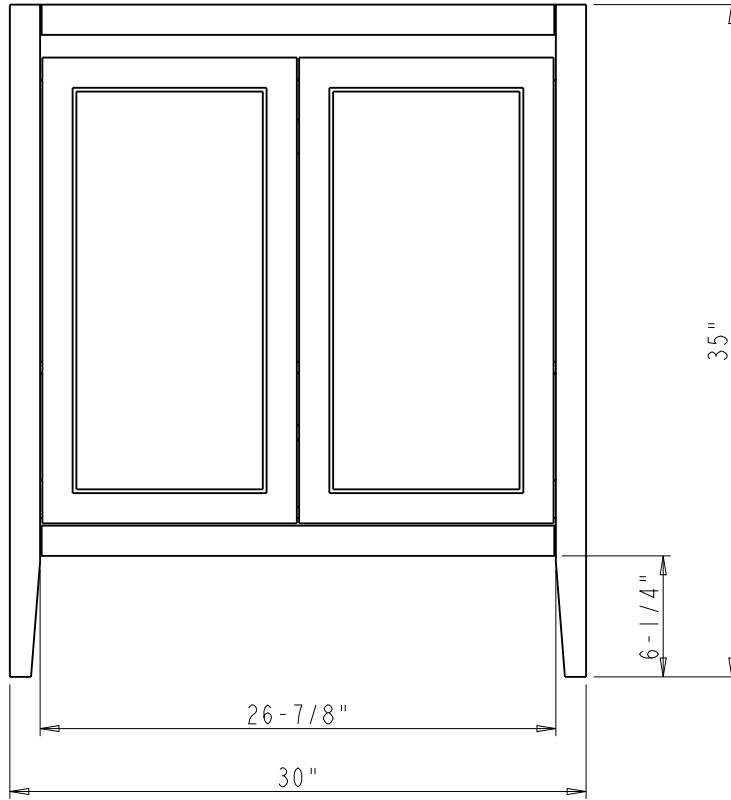



| | | | | |
|---|---------------------------------------|-----------|-----------------|--|
|  PROPRIETARY AND CONFIDENTIAL THE INFORMATION CONTAINED IN THIS DRAWING IS THE SOLE PROPERTY OF HARDWARE RESOURCES INC. ANY REPRODUCTION IN PART OR AS A WHOLE WITHOUT THE WRITTEN PERMISSION OF HARDWARE RESOURCES INC. IS PROHIBITED. | ITEM: | VN2PER-30 | | MATERIAL: |
| | FINISH: | | | WEIGHT: |
| | | | | 9 |
| | | | | PROJECTION  |
| | TOLERANCE UNLESS OTHERWISE SPECIFIED: | UNITS: | DRAWN BY: | DATE: |
| | X ±0.20 | | <i>Hugo.cai</i> | Apr-29-21 |
| | X.X ±0.10 | SIZE: | APPROVED BY: | DATE: |
| | X.XX ±0.05 | | | |
| | ANGULAR: ±0.5° | SHEET: | RELEASE LEVEL: | REVISION: |
| | DO NOT SCALE DRAWING | | | |