



ADJUSTABLE-SHELF

Item number	Finish	Deco Hardware	
		Item number	Qty
VN2KAT-48-BK-NT	Black	845-160PC	5
VN2KAT-48-BL-NT	Blue	845-160SBZ	5
VN2KAT-48-BS-NT	Blue Steel	845-160BG	5
VN2KAT-48-GN-NT	Green	845-160SBZ	5
VN2KAT-48-GR-NT	Grey	845-160MB	5
VN2KAT-48-WH-NT	White	845-160MB	5

Specification:

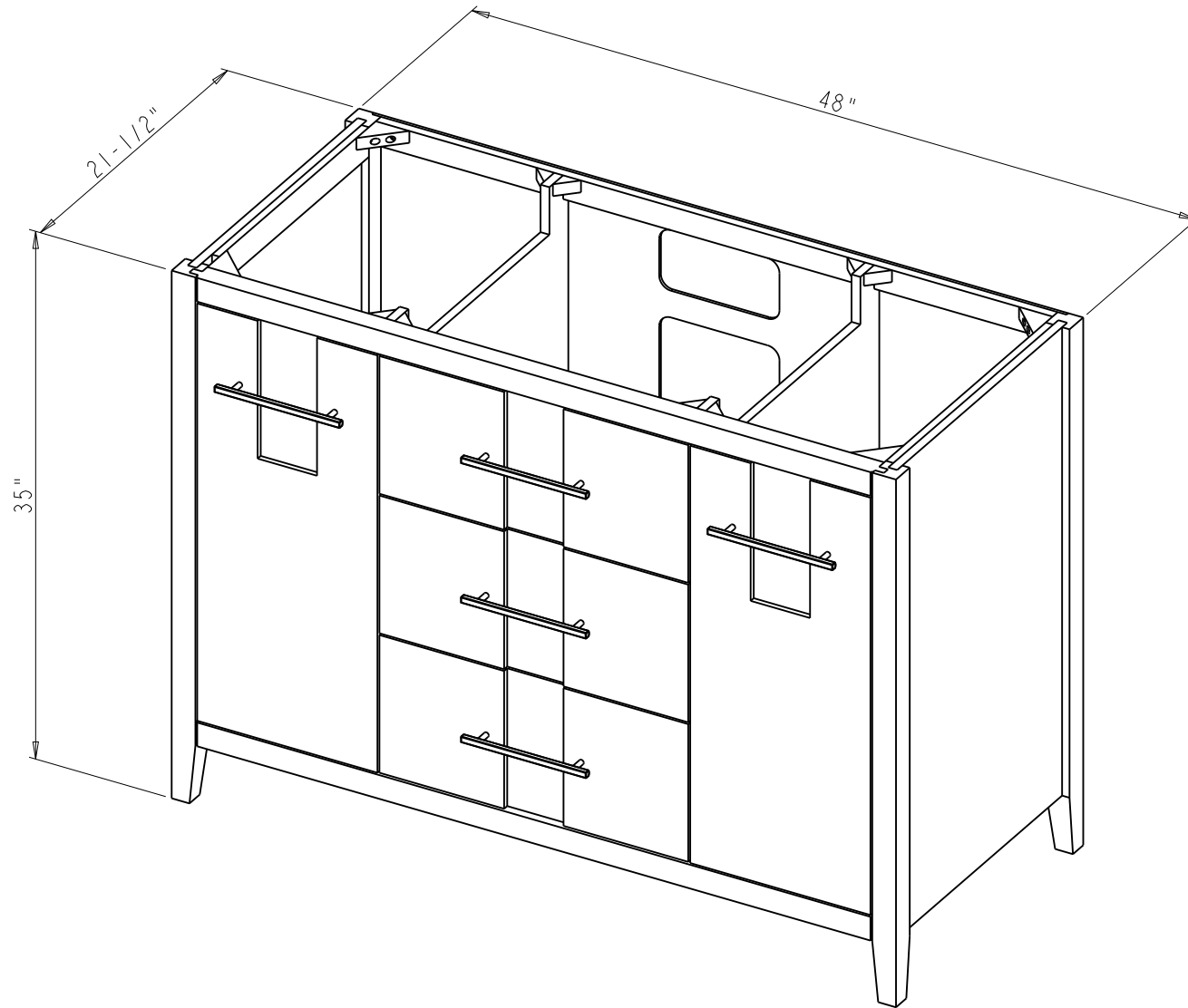

1. Material: MDF + Plywood + Birch
2. Finish: See Table
3. Hardware: See Table
4. Slides: USE58-300-18 + USCLIP2ND-4W(4 Set)
5. Hinge: 700.0536.25 + 600.1234.05 (2 Set)
700.0537.25 + 600.1234.05 (4 Set)
6. The tolerance is +/- 1/8"

 <p>PROPRIETARY AND CONFIDENTIAL</p> <p>THE INFORMATION CONTAINED IN THIS DRAWING IS THE SOLE PROPERTY OF HARDWARE RESOURCES INC. ANY REPRODUCTION IN PART OR AS A WHOLE WITHOUT THE WRITTEN PERMISSION OF HARDWARE RESOURCES INC. IS PROHIBITED.</p> <p>DO NOT SCALE DRAWING</p>	ITEM#: VN2KAT-48	MATERIAL:
	FINISH:	WEIGHT: 9
	PROJECTION 	
	TOLERANCE UNLESS OTHERWISE SPECIFIED: X ±0.20 X.X ±0.10 X.XX ±0.05 ANGULAR: ±0.5°	UNITS: DRAWN BY: Tony.Huang
SIZE:	APPROVED BY:	DATE:
SHEET:	RELEASE LEVEL:	REVISION:

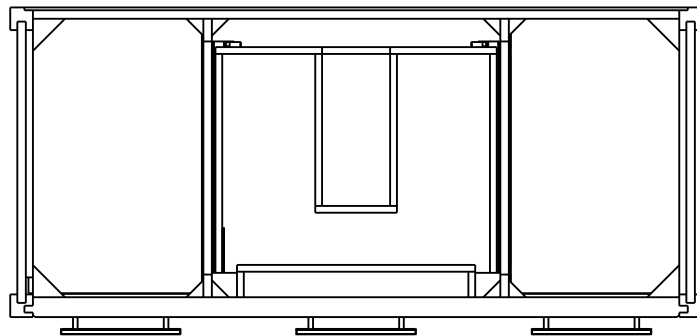
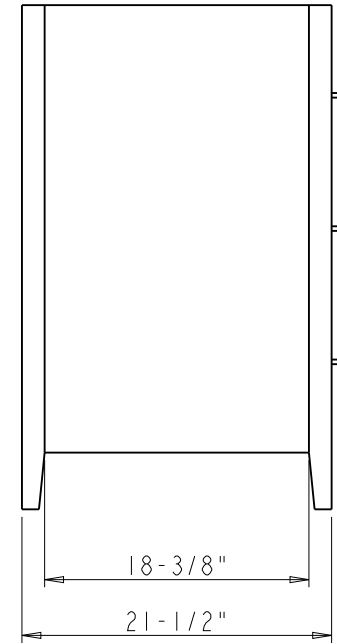
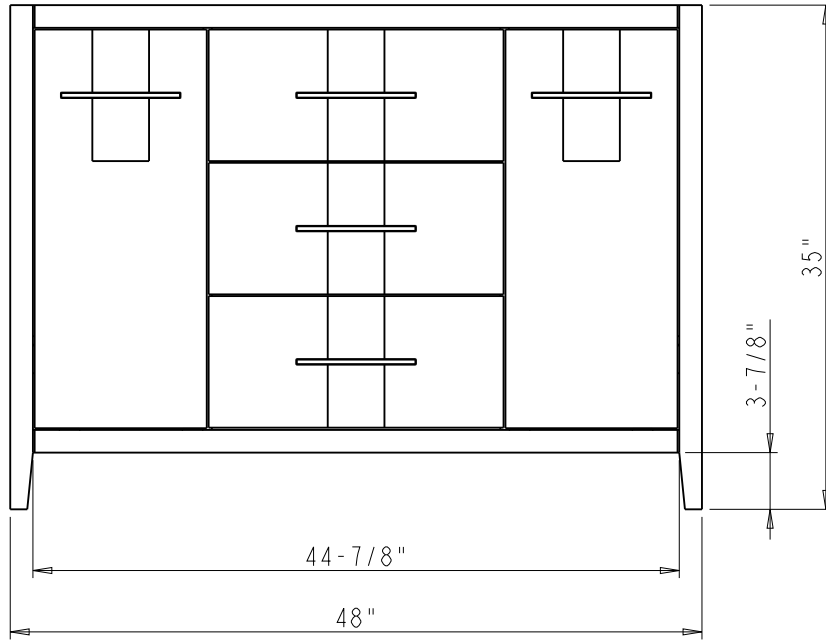

 <p>PROPRIETARY AND CONFIDENTIAL</p> <p>THE INFORMATION CONTAINED IN THIS DRAWING IS THE SOLE PROPERTY OF HARDWARE RESOURCES INC. ANY REPRODUCTION IN PART OR AS A WHOLE WITHOUT THE WRITTEN PERMISSION OF HARDWARE RESOURCES INC. IS PROHIBITED.</p>	ITEM#: VN2KAT - 48		MATERIAL:		
	FINISH:		WEIGHT: 9		
	TOLERANCE UNLESS OTHERWISE SPECIFIED: X ±0.20 X.X ±0.10 X.XX ±0.05 ANGULAR: ±0.5°		UNITS:	DRAWN BY: <i>Hugo.cai</i>	DATE: Jul-16-21
	DO NOT SCALE DRAWING		SIZE:	APPROVED BY:	DATE:
		SHEET:	RELEASE LEVEL:	REVISION:	



 PROPRIETARY AND CONFIDENTIAL THE INFORMATION CONTAINED IN THIS DRAWING IS THE SOLE PROPERTY OF HARDWARE RESOURCES INC. ANY REPRODUCTION IN PART OR AS A WHOLE WITHOUT THE WRITTEN PERMISSION OF HARDWARE RESOURCES INC. IS PROHIBITED.	ITEM:	VN2KAT - 48		MATERIAL:
	FINISH:			WEIGHT:
	TOLERANCE UNLESS OTHERWISE SPECIFIED:	UNITS:	DRAWN BY:	DATE:
	X ±0.20 X.X ±0.10 X.XX ±0.05 ANGULAR: ±0.5°	SIZE:	APPROVED BY:	DATE:
DO NOT SCALE DRAWING	SHEET:	RELEASE LEVEL:	REVISION:	PROJECTION 
				9