

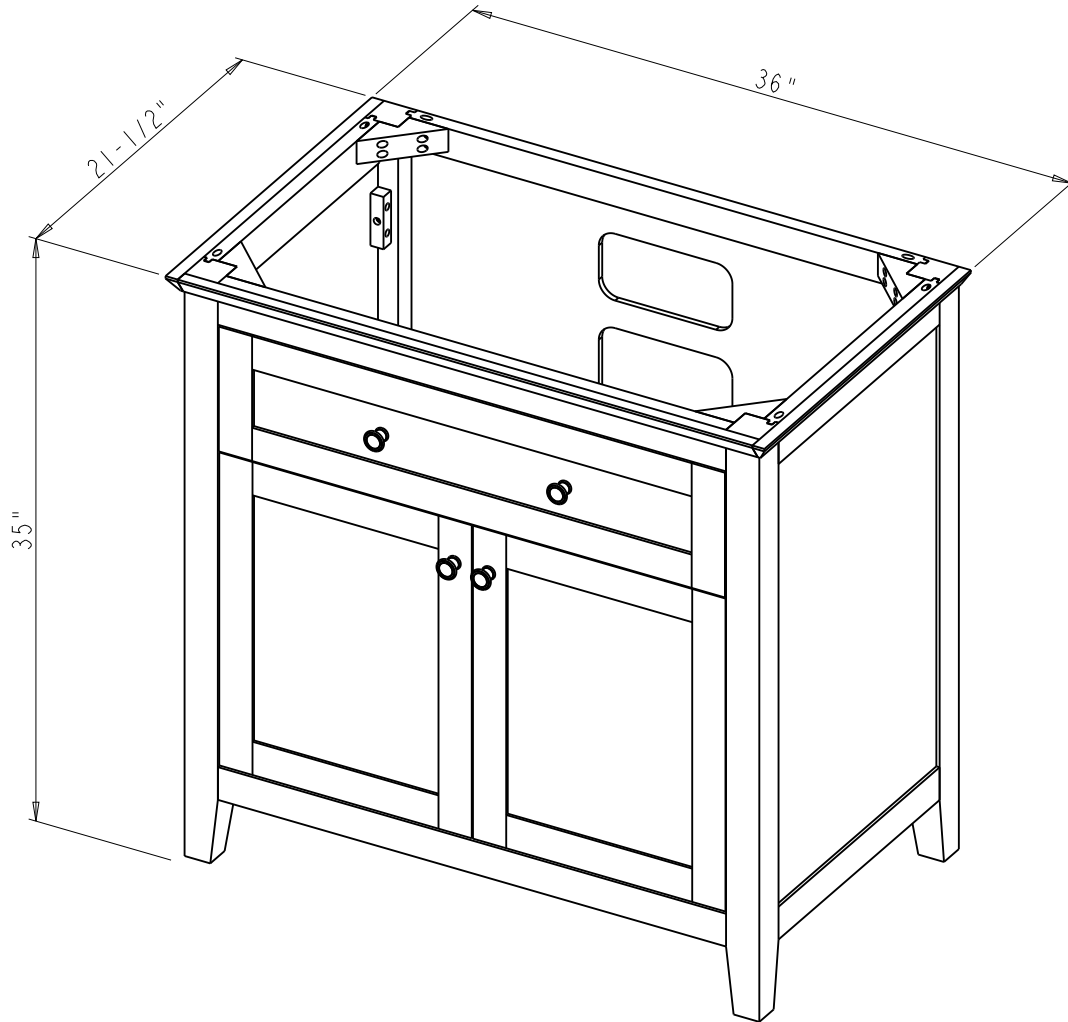

Specification:

1. Material: Plywood + Birch
2. Finish: See Table
3. Hardware: See Table
4. Slides: USE58-300-18 + USCLIP2ND-4W (1 Sets)
5. Shelf Supports: 1707BN (4 PCS)
6. Drawer Boxes: 5/8" Rubber wood
Clear color
Dovetail
7. Tipout Hinge: 700.0536.25 + 600.1234.05 (2 Sets)
Door Hinge: 700.0537.25 + 600.1234.05 (4 Sets)
8. Lid Stay (1 PC)
9. The tolerance is +/- 1/8"



Item number	Finish	Deco Hardware	
		Item number	Qty
VN2CHA-36-BL-NT	Blue	658SBZ	4
VN2CHA-36-CH-NT	Chocolate	Z110-SN	4
VN2CHA-36-GR-NT	Grey	Z110-SN	4
VN2CHA-36-WH-NT	White	Z110-SN	4

<p>hardware resources</p> <p><small>PROPRIETARY AND CONFIDENTIAL</small></p> <p><small>THE INFORMATION CONTAINED IN THIS DRAWING IS THE SOLE PROPERTY OF HARDWARE RESOURCES INC. ANY REPRODUCTION IN PART OR AS A WHOLE WITHOUT THE WRITTEN PERMISSION OF HARDWARE RESOURCES INC. IS PROHIBITED.</small></p> <p><small>DO NOT SCALE DRAWING</small></p>	ITEM#: VN2CHA-36	MATERIAL:	
	FINISH:	WEIGHT: 0 g	
	TOLERANCE UNLESS OTHERWISE SPECIFIED: X ±0.20 X.X ±0.10 X.XX ±0.05 ANGULAR: ±0.5°	UNITS:	DATE: Nov-22-21
	PROJECTION	DRAWN BY: Tony.Huang	DATE:
	APPROVED BY:	DATE:	
	RELEASE LEVEL:	REVISION:	

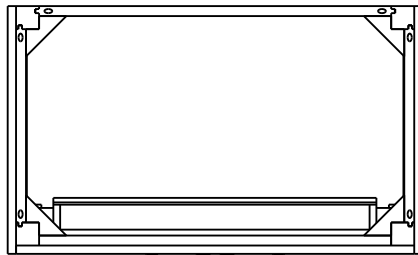
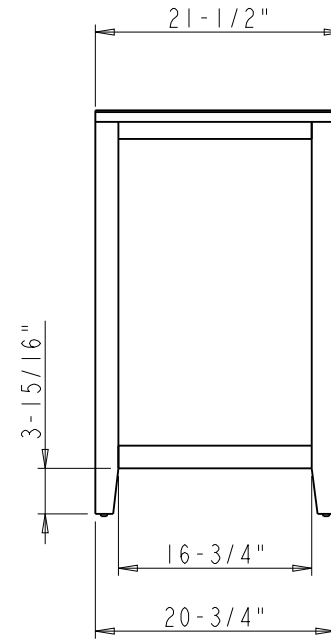
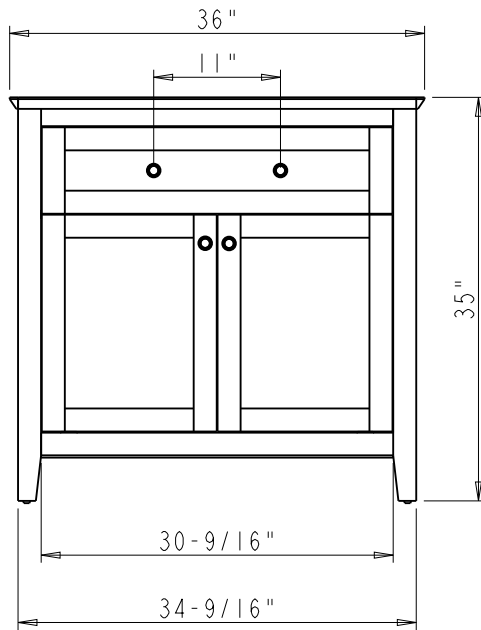

 PROPRIETARY AND CONFIDENTIAL THE INFORMATION CONTAINED IN THIS DRAWING IS THE SOLE PROPERTY OF HARDWARE RESOURCES INC. ANY REPRODUCTION IN PART OR AS A WHOLE WITHOUT THE WRITTEN PERMISSION OF HARDWARE RESOURCES INC. IS PROHIBITED.	ITEM#: VN2CHA - 36		MATERIAL:		
	FINISH:		WEIGHT: 0 g		
	TOLERANCE UNLESS OTHERWISE SPECIFIED: X ±0.20 X.X ±0.10 X.XX ±0.05 ANGULAR: ±0.5°		UNITS:	DRAWN BY: <i>Tony.Huang</i>	DATE: Apr - 14 - 22
	DO NOT SCALE DRAWING		SIZE:	APPROVED BY:	DATE:
		SHEET:	RELEASE LEVEL:	REVISION:	



 <p>PROPRIETARY AND CONFIDENTIAL</p> <p>THE INFORMATION CONTAINED IN THIS DRAWING IS THE SOLE PROPERTY OF HARDWARE RESOURCES INC. ANY REPRODUCTION IN PART OR AS A WHOLE WITHOUT THE WRITTEN PERMISSION OF HARDWARE RESOURCES INC. IS PROHIBITED.</p> <p>DO NOT SCALE DRAWING</p>	ITEM:	VN2CHA - 36		MATERIAL:	
	FINISH:			WEIGHT:	
				0	g
				PROJECTION	
TOLERANCE UNLESS OTHERWISE SPECIFIED:		UNITS:	DRAWN BY:		DATE:
X ±0.20			<i>Tony.Huang</i>		Apr - 14 - 22
X.X ±0.10		SIZE:	APPROVED BY:		DATE:
X.XX ±0.05					
ANGULAR: ±0.5°		SHEET:	RELEASE LEVEL:		REVISION: