

Adjustable-Shelf



Specification:

1. Material: MDF + Plywood + Birch
2. Finish: See Table
3. Hardware: See Table
4. Slides: USE58-300-18 + USCLIP2ND-4W (5 Sets)
5. Hinge: 700.0536.25 + 600.1234.05 (4 Sets)
700.0537.25 + 600.1234.05 (4 Sets)
- 6 Shelf Supports: 1707 (8 PCS)
7. The tolerance is +/- 1/8"

Item number	Finish	Deco Hardware			
		Item number	Qty	Item number	Qty
VN2CAD-60-BK-NT	Black	625-320PC	4	625-3PC	3
VN2CAD-60-GR-NT	Grey	625-320PC	4	625-3PC	3
VN2CAD-60-WH-NT	White	625-320PC	4	625-3PC	3

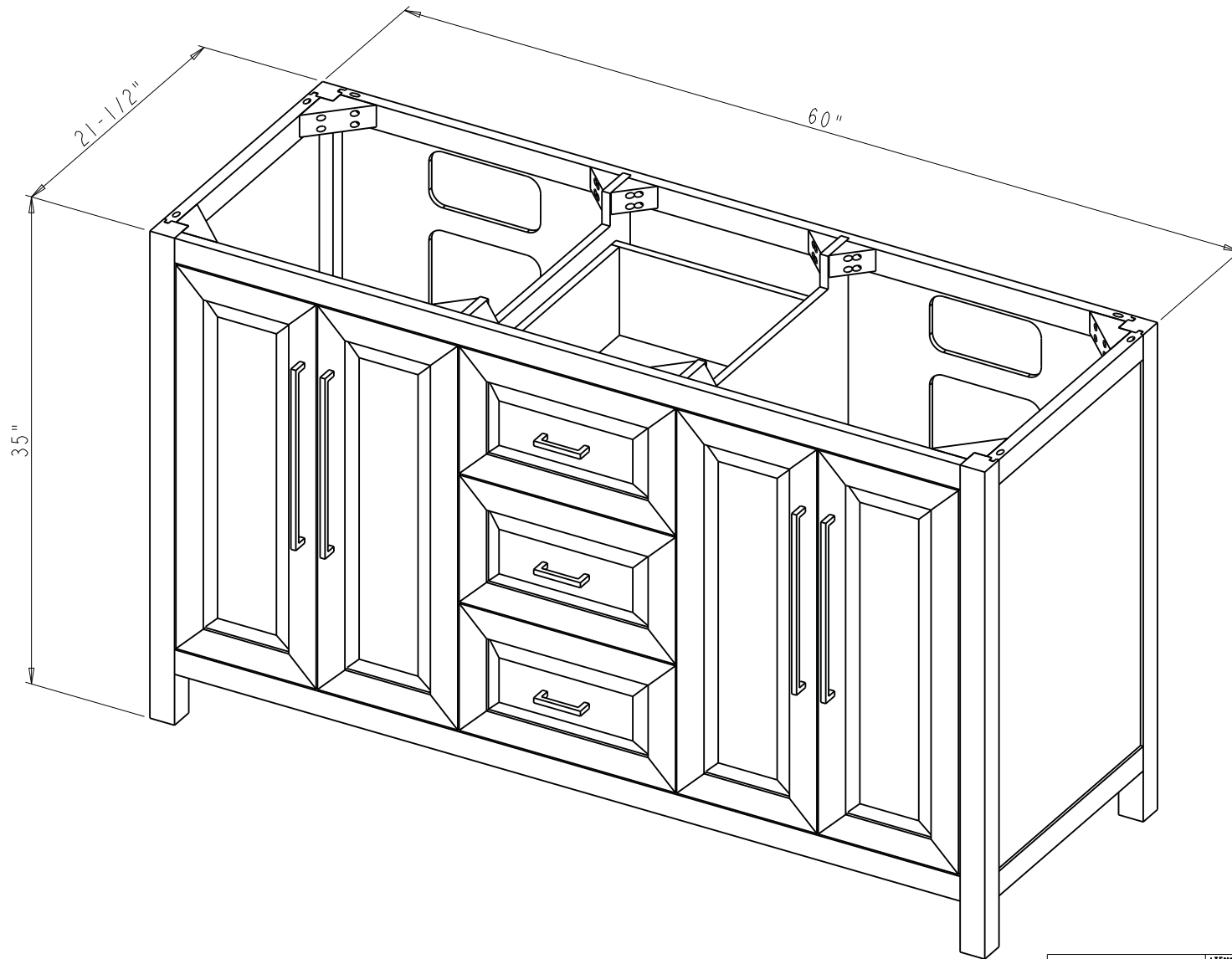
<p>PROPRIETARY AND CONFIDENTIAL</p> <p>THE INFORMATION CONTAINED IN THIS DRAWING IS THE SOLE PROPERTY OF HARDWARE RESOURCES INC. ANY REPRODUCTION IN PART OR AS A WHOLE WITHOUT THE WRITTEN PERMISSION OF HARDWARE RESOURCES INC. IS PROHIBITED.</p> <p>DO NOT SCALE DRAWING</p>	ITEM:	VN2CAD-60		MATERIAL:
	FINISH:			WEIGHT:
				PROJECTION
	TOLERANCE UNLESS OTHERWISE SPECIFIED:	UNITS:	DRAWN BY:	DATE:
X ±0.20		Tony.Huang	Nov-22-21	
X.X ±0.10	SIZE:	APPROVED BY:	DATE:	
X.XX ±0.05	SHEET:	RELEASE LEVEL:	REVISION:	
ANGULAR: ±0.5°				



 <p>PROPRIETARY AND CONFIDENTIAL</p> <p>THE INFORMATION CONTAINED IN THIS DRAWING IS THE SOLE PROPERTY OF HARDWARE RESOURCES INC. ANY REPRODUCTION IN PART OR AS A WHOLE WITHOUT THE WRITTEN PERMISSION OF HARDWARE RESOURCES INC. IS PROHIBITED.</p> <p>DO NOT SCALE DRAWING</p>	ITEM:	VN2CAD - 60		MATERIAL:	
	FINISH:			WEIGHT:	9
				PROJECTION	
	TOLERANCE UNLESS OTHERWISE SPECIFIED:	UNITS:	DRAWN BY:	DATE:	
X ±0.20		<i>Hugo.cai</i>	Mar - 16 - 20		
X.X ±0.10	SIZE:	APPROVED BY:	DATE:		
X.XX ±0.05	SHEET:	RELEASE LEVEL:	REVISION:		
ANGULAR: ±0.5°					

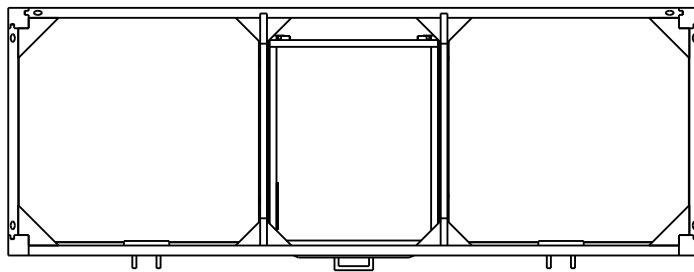
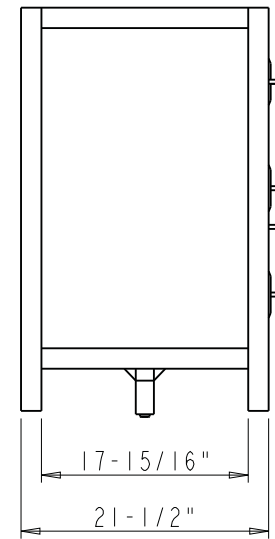
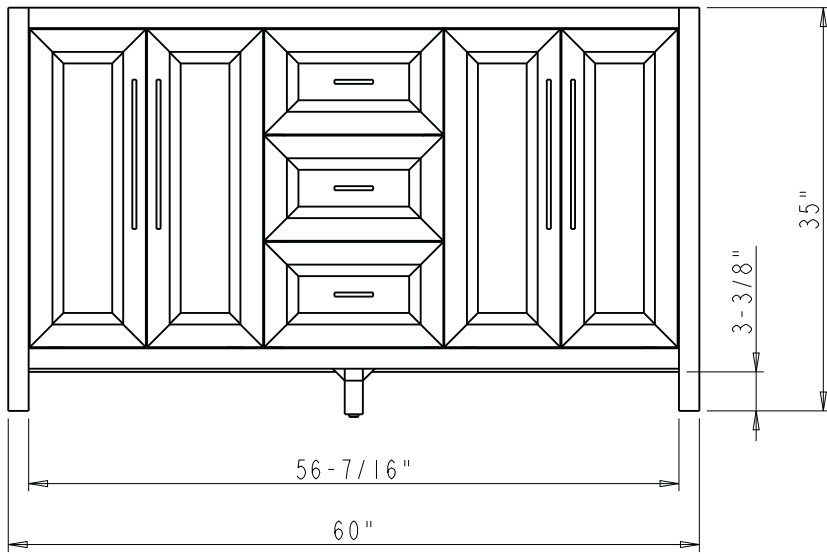

	ITEM#: VN2CAD-60		MATERIAL:			
	FINISH:		WEIGHT:			
<p>PROPRIETARY AND CONFIDENTIAL</p> <p>THE INFORMATION CONTAINED IN THIS DRAWING IS THE SOLE PROPERTY OF HARDWARE RESOURCES INC. ANY REPRODUCTION IN PART OR AS A WHOLE WITHOUT THE WRITTEN PERMISSION OF HARDWARE RESOURCES INC. IS PROHIBITED.</p> <p>DO NOT SCALE DRAWING</p>	UNITS:		DRAWN BY: <i>Hugo.cai</i>		DATE: Mar-16-20	
	TOLERANCE UNLESS OTHERWISE SPECIFIED: X ±0.20 X.X ±0.10 X.XX ±0.05 ANGULAR: ±0.5°		APPROVED BY:		DATE:	
	SIZE:		RELEASE LEVEL:		REVISION:	
	SHEET:					

