

CEILING FAN INSTALLATION INSTRUCTIONS

Please read and save these instructions



**These instructions are to be used in
the installation of the following fans...**



JAMES ALLEN

1. SAFETY RULES

Model #196608-xx: 26.12 lbs
Model #196728-xx: 28.06 lbs

1. To avoid possible electric shock, **turn off the electricity** at the main fuse box or circuit panel before you begin the fan installation or before servicing the fan or installing accessories.
2. Read all instructions and safety information carefully before installing your fan and **save these instructions**.
3. Make sure all electrical connections comply with local codes or ordinances as well as the National Electrical Code. If you are unfamiliar with electric wiring, please use a qualified and licensed electrician.
4. Make sure you have a location selected for your fan which allows clear space for the blades to rotate, and at least seven (7) feet of clearance between the floor and the fan blade tips.
5. The outlet box and ceiling support joist used must be securely mounted, and **capable of supporting at least 50 pounds**. To reduce the risk of fire, electric shock, or personal injury, use only an outlet box clearly labeled "**Acceptable For Fan Support**".
6. To reduce the risk of personal injury use only approved hanging brackets and screws supplied with the outlet box for mounting to the outlet box.
7. After installation is complete, check that all connections are absolutely secure.
8. Do not insert anything into the fan blades while they are rotating.
9. To operate the reverse function on the fan, press the reverse button on the wall transmitter while the fan is running.

10. Do not attempt to control the operation of the fan (or an optional light kit) from any wall control that is not approved by for use with its fans. Do not use solid state wall controls. The use of any unapproved control voids the fan's warranty.

11. Federal regulations require all ceiling fans with light kits manufactured or imported after January 1, 2009, to limit total wattage consumed by the light kit to 190W. Therefore, this fan is equipped with a wattage limiting device.

TOOLS REQUIRED FOR INSTALLATION

Phillips Screwdriver
Wire Cutters
Electrical Tape
Step Ladder

2. UNPACKING YOUR FAN

Unpack your fan and check the contents. Do not discard the carton. If warranty replacement or repair is ever necessary the fan should be returned in original packaging. Remove all parts and hardware. Do not lay motor housing on its side - because the decorative casing may shift. Check all visible screws, bolts and nuts for tightness. Examine all parts. The following parts should be included:

1. Set of blades (a)
2. Blade support plates (b)
3. Hanging bracket (c)
4. Canopy (d)
5. Canopy cover (e)
6. Downrod assembly (4") and Alternate downrod (6") (f)
7. Yoke cover (g)
8. Fan motor assembly (h)
9. Motor bottom housing (i)
9. Control cup (j)
10. Control cup plate (k)
11. Decorative screw (l)
12. Wall transmitter incl. 2 mounting screws and 3 wire nuts (m)
13. 2 wall plates (white and almond), 1 face plate (almond), 2 sets of mounting screws, and machine screws (n)
14. Blade balancing kit (o)
15. Battery (p)
16. Parts bags (q) containing:
 - Blade attachment hardware (Screws/lock washers, washers may be attached to screws)
 - Mounting hardware (wire nuts, wood screws, machine screws, lock washers, spring washers, metal washers.)

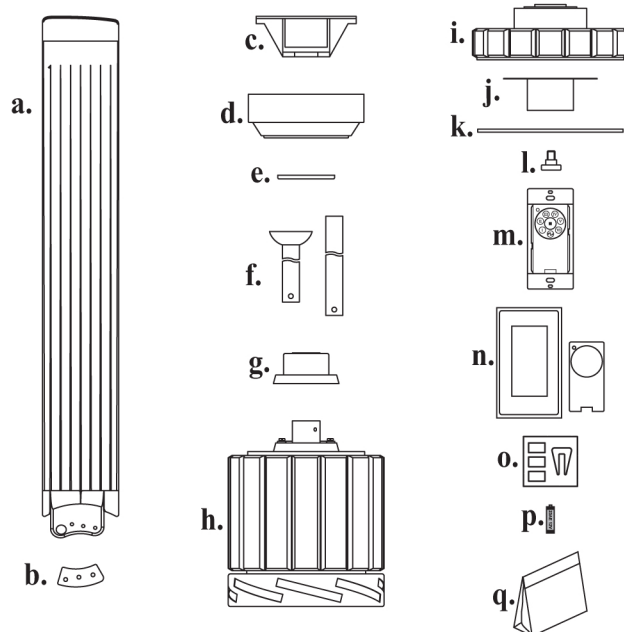

NOTE:

Some fan models will have slightly different parts than what is shown here depending upon the design you have chosen. Basic installation procedures are similar for all models.

IF YOU FIND THAT PARTS ARE MISSING, CONTACT YOUR DEALER FOR REPLACEMENT, OR CALL DIRECTLY AND WE WILL MAIL REPLACEMENTS TO YOU IMMEDIATELY.

3. MOUNTING OPTIONS

1. Disconnect the power by removing fuses or turning off circuit breakers.

2. If there is an existing outlet box, ensure it is clearly marked "Suitable for Fan Support". If it is not so marked, it must be replaced with an approved one.

3. Secure the outlet box (or make sure the existing box is secured) directly to the building structure. Use appropriate fasteners and building materials.

4. Figures 1,2 and 3 are examples of different ways to mount the outlet box in different situations. A longer downrod may be required in sloped ceiling situations to maintain proper blade clearance.

5. To hang the fan in locations where no ceiling joist is available, a hanger support bar may be required (Figure 4).

WARNING: TO REDUCE THE RISK OF ELECTRIC SHOCK, FIRE, OR PERSONAL INJURY, MOUNT THE FAN ONLY TO AN OUTLET MARKED ACCEPTABLE FOR FAN SUPPORT AND USE MOUNTING SCREWS PROVIDED WITH THE OUTLET BOX.

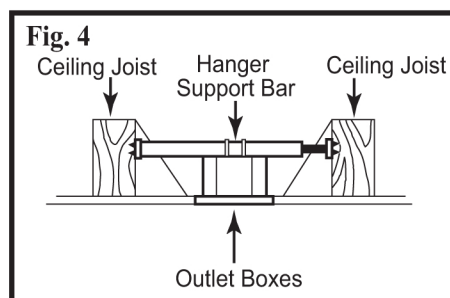
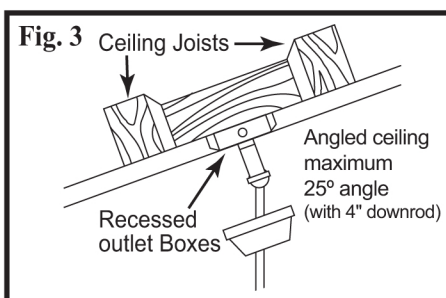
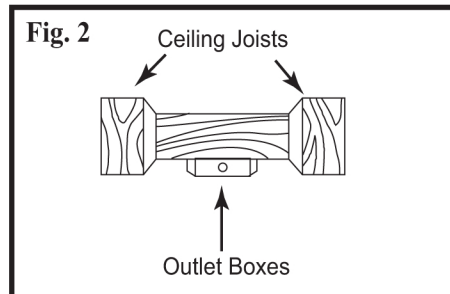
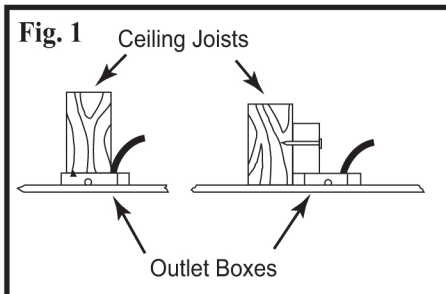

CAUTION: TO REDUCE THE RISK OF PERSONAL INJURY, INSTALL THE PRIMARY MOUNTING MEANS AND USE ONLY THE HARDWARE PROVIDED WITH THE FAN.

4. HANGING YOUR FAN

WARNING - Turn off the power!

DO NOT fasten the blades to the fan until it is assembled and hanging from the ceiling. To do so now will likely bend the blade arms and almost certainly cause wobble.

CAUTION: Remove 4 rubber packing mounts from fan motor assembly and discard before installation.

1. If not already affixed to the hanger bracket, place the rectangular rubber isolators between the hanger bracket and outlet box. Secure the hanger bracket to the outlet box using the 2 long steel screws supplied with the outlex box.

2. Remove the set pin and safety lock clip from the yoke on top of the motor assembly. Slide the downrod through the canopy and canopy cover. Slide the yoke cover onto the downrod (Fig. 5). Feed the wires from the fan motor through the downrod assembly.

3. (Fig. 6) Attach the downrod assembly (downrod, yoke cover, canopy and canopy cover) to the motor by sliding the downrod into the yoke on top of the motor assembly. Slide the set pin through the hole in the yoke, downrod and secure it with the safety lock clip. Tighten the set screws on yoke. The yoke cover will lower down to conceal the yoke. Feed the wires through the downrod ball.

4. Lift the fan motor without the blades and place into the hanger bracket, rotating the ball until the groove engages the tab on the hanger bracket. This locks the ball mount and fan motor, preventing fan rotation during operation. (Fig. 7)

Fig. 5

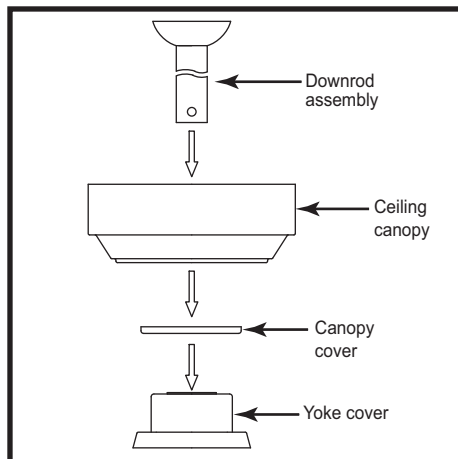

Fig. 7

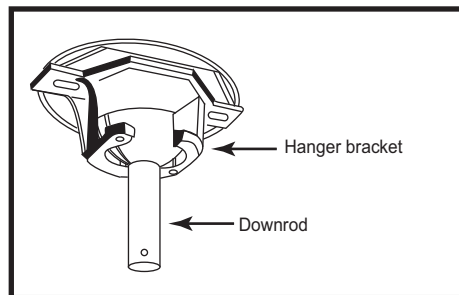
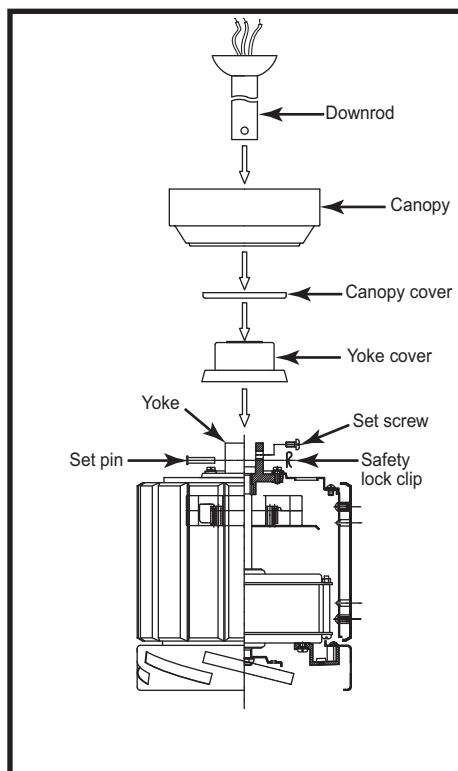

Fig. 6



5. ELECTRICAL CONNECTIONS

REMEMBER -Turn off the power!

Use the wire nuts supplied with your fan when making connections. Secure the connectors with electrical tape and make sure there are no loose connections or wire strands.

1. Spread the wires apart so that the black wire from the fan is on one side of the mounting bracket and the white wire and green ground wire are on the other side.

2. (Fig. 8) Connect the BLACK building supply wire to the BLACK fan wire. Connect the WHITE building neutral wire to the WHITE fan neutral wire. Connect the COPPER building ground wire to the GREEN fan ground wire.

3. Inside the ceiling junction box be sure to spread the wires apart so that the black connection is on one side of the outlet box and the white/white and green/copper connections are on the other side.

4. Connect the wiring from the wall switch receptacle to wall transmitter unit.

- Remove the existing wall plate and switch from the wall junction box.
- Connect one BLACK wire from the wall to one BLACK wire (labeled "TO FAN") from the wall transmitter.
- Connect the other BLACK wire (labeled "TO POWER SUPPLY") from the transmitter to the remaining BLACK wire from the wall (A/C supply source).

- If your junction box has a ground wire (green or bare copper), connect the transmitter's ground wire to it. Otherwise, connect the transmitter ground wire directly to one of the screws from the outlet box.

- Carefully tuck the connected wires inside the junction box. Secure the transmitter with the two screws provided. Attach the face plate over the transmitter with the two screws provided.

5. Inside the ceiling junction box be sure to spread the wires apart so that the black connection is on one side of the outlet box and the white/white and green/copper connections are on the other side.

Use **ONLY** wall controls approved. Use of unapproved wall controls will cause unacceptable humming noise, and voids the fan warranty.

Hook up in "series only" do **not** connect the hot and neutral wires of electric circuit to the transmitter wall switch - damage to the switch and possible fire could occur.

Fig. 8

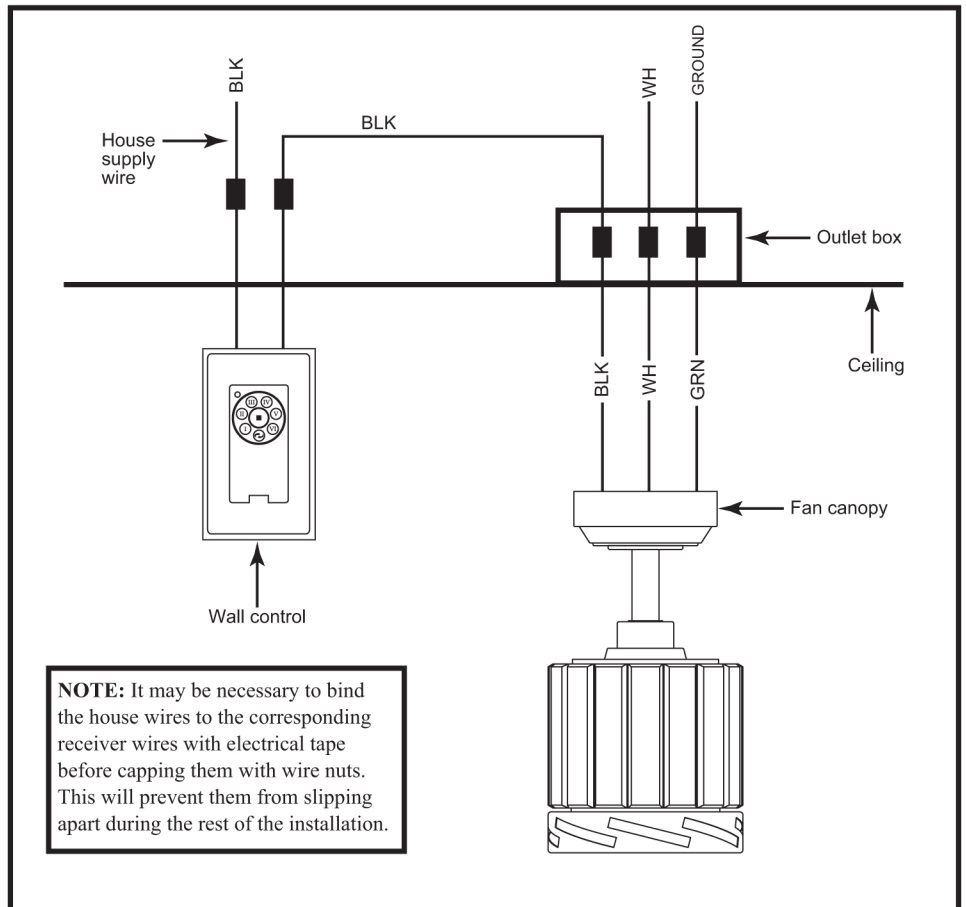

6. COMPLETING THE INSTALLATION

1. Make sure the wiring is safely inside the outlet box as instructed in **Step 5 - Electrical Connections**. To install the canopy, slide the canopy up to hanger bracket and place the key hole on the canopy over the screw on the hanger bracket, turn canopy until it locks in place at the narrow section of the key holes. (Fig. 9) Align the circular hole on canopy with the remaining hole on the hanger bracket, secure by tightening the two set screws, lift canopy cover and attach by turning clockwise. **Note:** Adjust the canopy screws as necessary until the canopy and canopy cover are snug. (Fig. 9)

Fig. 9

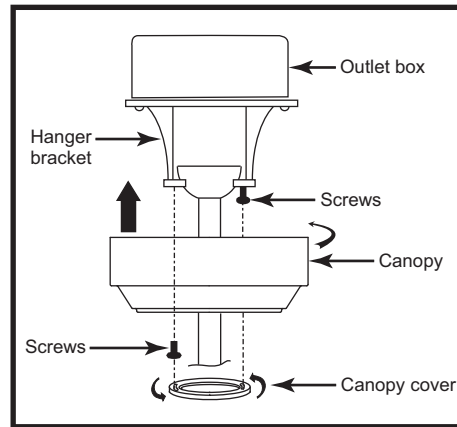

2. Installing the Blades

Insert the blade through the access window from the blade holder. Align holes from the blade and motor and secure with screws and blade support plate. Repeat process with the other blades. (Fig. 10) **DO NOT bend the blade arms when installing the blades.**

Fig. 10

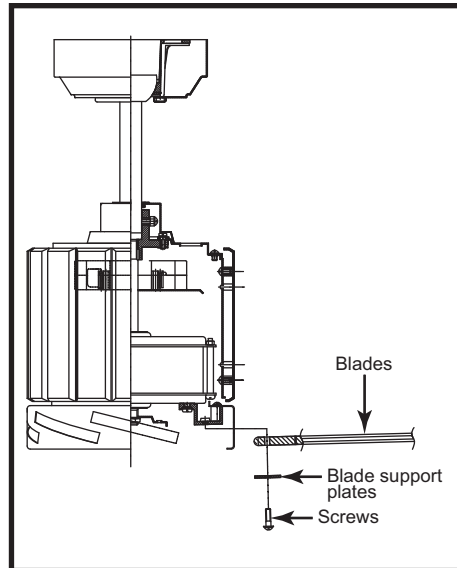

3. Attaching the Motor Bottom Housing

Attach the bottom housing to the mounting ring of the motor by using the three screws provided that are pre-installed on the mounting ring. (Fig. 11)

Fig. 11

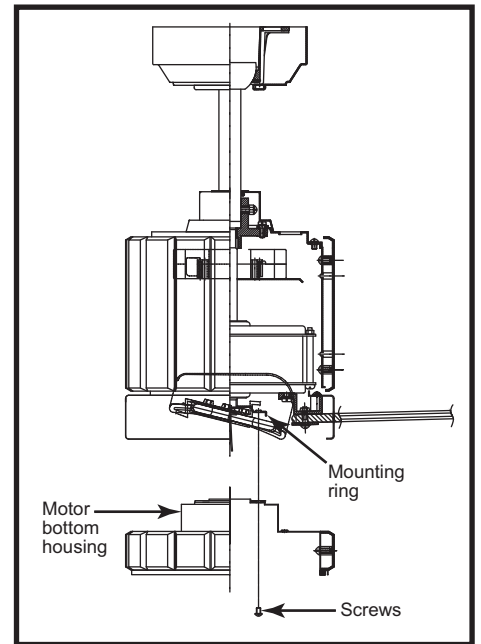

4. Attaching the Control Cup

Attach the control cup to the flange of the motor by using the three screws provided that are pre-installed on the flange. (Fig. 12)

Fig. 12

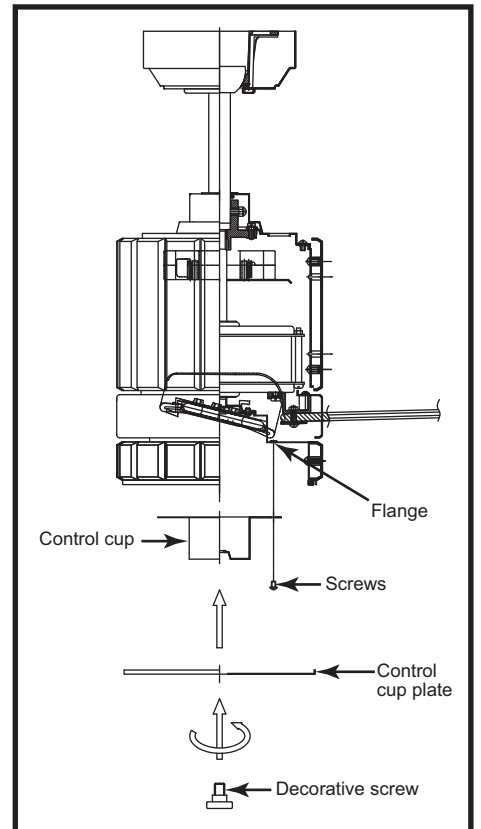

5. Attaching the Control Cup Plate

Attach the control cup plate to the control cup with the decorative screw provided. (Fig. 13)

7. INSTALLING THE WALL CONTROL

REMEMBER -Turn off the power!

Hook up in "series only" do **not** connect the hot and neutral wires of electric circuit to the transmitter wall switch - damage to the switch and possible fire could occur.

1. Remove the existing wall plate and switch from the wall junction box.
2. If your outlet box has a ground wire (green or bare copper) connect the wall control's ground wire to it; otherwise connect the wall control's ground wire directly to one of the screws from the outlet box.

3. (Fig. 13) Carefully tuck the wire connections inside the junction box. Secure the wall control with the two screws provided. Attach the wall plate over the wall control and secure with the two screws provided.

Fig. 13

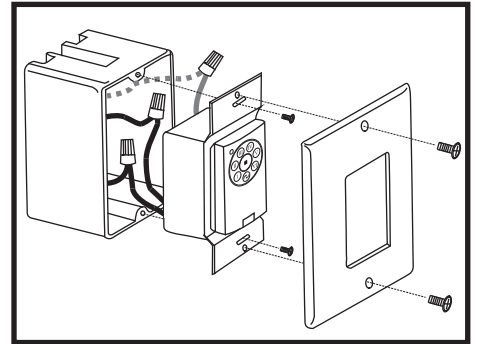

8. OPERATING YOUR TRANSMITTER

Your DC brushless motor is equipped with an automatically learned type remote control. There are no frequency switches on the receiver; the receiver unit will automatically scan the frequency from the wall control if any changes are made. The frequency settings on the transmitter should be changed only in case of interference or if a second or more ceiling fans with the same type of control system are installed in the same structure. (Fig. 14) (It is recommended that you not use the factory code settings. Change codes setting to any other combination of dip switch setting to avoid issues).

Remove the panel from the transmitter and then install one 23A/12V battery (included). To prevent damage to transmitter, remove the battery if not use for long periods of time (Fig. 14).

- A. I, II, III, IV, V and VI buttons:
These six buttons are used to set the fan speed as follows:
I = minimum speed
II = low speed
III = medium low speed
IV = medium speed
V = medium high speed
VI = high speed
- B. ■ button:
This button turns the fan off.
- C. ↻ Reverse button:
This button is to control fan direction.
- D. "SET" code setting button:
Follow the below steps to use the set button.

Step 1. With the fan's power off, arrange code switches to desired code setting.

Step 2. After installing the unit and restoring power to the fan, press and hold the "SET" button 1 - 5 seconds. You must press the "SET" button within 60 seconds of restoring power to the fan.

Step 3. The fan will start to run and begin the control setting process. The fan will run in both directions for a total of approximately 5 minutes.

Step 4. When the fan stops after approximately 5 minutes, the control and speed setting process is complete and the fan is ready for use.

NOTE: If you want to change the blades: 1. Turn off the power. 2. change the blades. 3. turn the power on. 4. replay the step 2,3,4.

The receiver provides the following protective function:

1. **Lock position:** The DC motor has a built-in safety against obstruction during operation. The motor will be locked operation and disconnect power after 30 seconds of interruption. Please remove obstacles before re-set.
2. **Over 80W protection:** When the receiver detects motor power consumption which is greater than 80W, the receiver power will be stopped and operation will immediately discontinue. Turn the receiver power on after 5 seconds.

Fig. 14

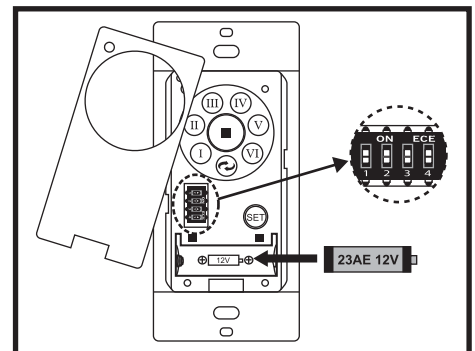
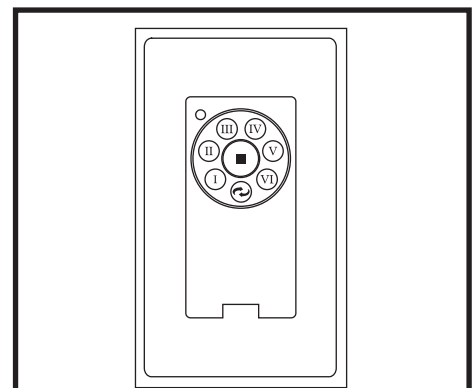

Fig. 15



9. FAN OPERATION AND CARE

1. A ceiling fan is an environmentally smart choice to cool as well as to help warm your home or office. Adjust your HVAC thermostat during fan use to save additional energy and money on your air conditioning and heating utility bills. You should see a significant reduction in both your heating and cooling costs by regular use of your fan.

Do not hesitate to use your fan during summer and winter months. In summer, (Fig. 16) using the reverse switch, adjust the fan's direction so cool air is blown down, producing a cooling breeze. In winter, (Fig. 17) reverse the fan so that an upward airflow will push warm air off the ceiling and circulate it downwards into the living area. In winter months, use the fan at a lower speed than summer.

2. Periodically check tightness of all screws securing the blades to the blade arm attachment points. A clicking or a rattling noise is a sure indication of loosening screws. Since screws will invariably work loose over time, at least once a year, tighten all the screws attaching blades to blade arms. **Do not bend blade arms when cleaning or servicing the fan.**

3. Clean you fan periodically using only a cloth dampened with a mild detergent solution for all hardware - never use solvents. The finish plating is lacquered to prevent tarnishing. Use a lint-free cloth with clean water to clean blades.

4. You will never need to oil or lubricate your fan. Its permanently sealed bearings will provide trouble free, silent operation for many years.

5. If repairs or servicing are ever required, to avoid possible electric shock, **turn off the electricity** at the main fuse or circuit panel before you begin.

Fig. 16

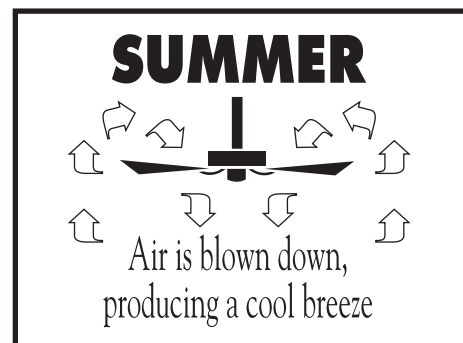
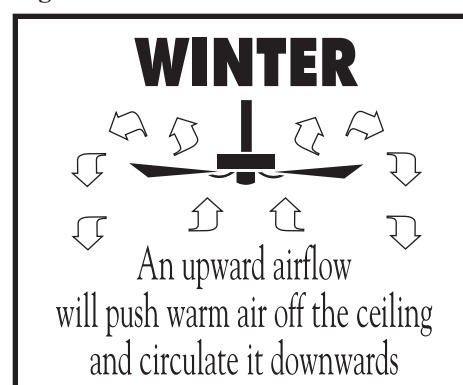

Fig. 17



10. TROUBLESHOOTING

FAN WILL NOT START

1. Check that the electricity has been turned on at the circuit breaker which had probably been turned off during installation.
2. Turn off the electricity. Check all connections in the wiring of the fan at the ceiling and make sure it follows the wiring instructions outlined in this manual.
3. Be sure ON/OFF power switch on the wall control is in ON position.

NOISE

Note: Always allow a day or two "run-in" time for any new fan at medium or high speed. When attempting to diagnose noise, listen carefully from several sides to try and isolate the location of the noise (blade, upper end, motor, light kit, etc.)

1. Tighten all screws attaching blades to blade arms. Remember to tighten these screws at least once a year because they may loosen slowly over time and cause a clicking noise.
2. Turn off the power. Loosen the canopy and check that the wiring and/or wire nut connectors are not resting against the canopy, possibly vibrating while the fan is on.

3. Use of a standard light rheostat or an unapproved fan wall control to control the fan speed will always cause an annoying "hum". Many fan motors do not work quietly with solid state variable speed controls.

4. Check that the rubber gasket on the mounting bracket has been installed if called for in the installation instructions.

5. Check that the canopy is not touching the ceiling.

6. Check that all screws on the motor housing and the bottom housing are tight.

FAN TURNS, BUT DOES NOT MOVE MUCH AIR

1. The fan may be running in reverse. Press the reverse button on transmitter to set the fan in forward operation.
2. The distance from the ceiling to the blades may be too small. For downrod fans, optimal placement would be 8-9 feet from the floor.
3. The room may contain items which obstruct the air flow.
4. The fan may be too small for the size of the room.

EXCESSIVE WOBBLE

Note: A small amount of wobble is considered acceptable and should not be considered a defect.

1. Make certain all blades are tightly attached to each blades' respective blade arm.

REPLACEMENT PARTS AVAILABLE

A full range of genuine replacement spare parts are available at reasonable cost directly. Please call us at (817) 626-5483. Monday through Friday from 8:00 A.M. to 5:00 P.M. CST.