



**Jacuzzi® Branded Walk-in
Shower Series**

INSTALLATION AND OPERATION INSTRUCTIONS

Jacuzzi® Luxury Bath
14525 Monte Vista Avenue
Chino, CA 91710
1-800-288-4002
www.jacuzzi.com

Contents

Contents	2
Product Information	2
Important Safety Instructions	3
Visual Inspection	4
Framing and Support	4
Sub floor	4
Installation Procedure	5
Included Accessories	7
Accessory Installation Instructions	7
Fixed Shower Head Installation	7
Hand-Held Shower Head Installation	8
Curtain Rod Installation	8
Seat Installation	9
Plumbing Panel Access Instructions	10
Controls	11
Maintenance	11
Authorized Service	12
Warranty	13
Warranty Registration Card	15

Product Information

NOTE

Save these instructions for future use. Use the form below to record your model and serial number for future reference.

Date Purchased	_____
Purchased From	_____
Installed By	_____
Serial Number	_____
Model	_____

Installer: Leave the manual for the homeowner.
Homeowner: Read this manual and keep for future reference.

Dealer/Installer
Information

Important Safety Instructions

This is a professional grade product. A working knowledge of construction techniques, plumbing and electrical installation according to codes are required for proper installation and user satisfaction. We recommend that a licensed contractor perform the installation of all Jacuzzi Luxury Bath products. Our warranty does not cover improper installation related problems.

READ AND FOLLOW ALL INSTRUCTIONS. SAVE THESE INSTRUCTIONS.

Use this unit only for its intended use as described in this manual. Do not use attachments not recommended by the manufacturer. Never drop or insert any object into any opening.



RISK OF ACCIDENTAL INJURY OR DROWNING! Do not permit children to use this unit unless they are closely supervised at all times.



RISK OF ELECTRIC SHOCK! Do not permit electrical appliances (such as a hair dryer, lamp, telephone, radio or television) within 60" (1524mm) of this shower unit.



PROLONGED IMMERSION IN HOT WATER MAY INDUCE HYPERTHERMIA! Hyperthermia occurs when the internal temperature of the body reaches a level several degrees above the normal body temperature of 98.6°F (37°C). The symptoms of hyperthermia include an increase in the internal temperature of the body, dizziness, lethargy, drowsiness and fainting. The effects of hyperthermia include:

- A. Failure to perceive heat.
- B. Failure to recognize the need to exit the shower unit.
- C. Unawareness of impending hazard.
- D. Fetal damage in pregnant women.
- E. Physical inability to exit the bath.
- F. Unconsciousness resulting in danger of drowning.



This equipment is intended for indoor use only. Install the equipment in accordance with these instructions.



To avoid injury, use care when entering and exiting the shower unit.



Do not use drugs or alcohol before or during the use of a shower unit. Possible drowning may occur.



Use this unit only for its intended use as described in this manual.



Water temperature in excess of 104°F (40°C) may be injurious to your health. Check and adjust water temperature before use.

SAVE THESE INSTRUCTIONS.

The Company has obtained applicable code (standards) listings generally available on a national basis for products of this type. It is the responsibility of the installer/owner to determine specific local code compliance prior to installation of the product. Proper installation of the units is the responsibility of the installer. Jacuzzi Luxury Bath is not responsible for water damage due to improper installation. Product specifications are subject to change without notice.

Visual Inspection

- 1 Remove the shower unit from the shipping packaging. Be careful not to scratch the surface of the shower unit from exposed staples, screws, or nails. Retain the packaging until satisfactory inspection of the product has been made.
- 2 Inspect the shell and shower unit components. Should inspection reveal any damage or defect in the finish or visible damage to any components, do not install the shower unit. Damage or defect to the finish claimed after the shower unit is installed is excluded from the warranty. Jacuzzi Luxury Bath responsibility for shipping damage ceases upon delivery of the products in good order to the carrier.
- 3 Refer any claims for damage to the carrier. For definitions of warranty coverage and limitations, refer to the published warranty information packed with the product or in the back of this manual.

Framing and Support

READ ALL INSTALLATION INSTRUCTIONS COMPLETELY. IMPROPER INSTALLATION WILL VOID THE WARRANTY.

IMPORTANT

Make sure that walls and floors meet fire safety requirements of local building code and/or FHA/HUD Minimum Property Standards.

Observe all governing codes and ordinances.

- 1 Proper installation is your responsibility. Have a qualified technician install this shower unit.
- 2 It is the installer's responsibility to assure that plumbing installation is adequate and in conformance with the Uniform Plumbing Code (UPC).

A Technical Specification has been included with your shower unit. The Technical Specification will contain pertinent information regarding your Jacuzzi Luxury Bath product. Locate the Technical Specification at this time.

NOTES

Finished alcove must have correct interior dimensions, as shown in the rough-in diagrams in the Technical Specification, to properly install unit.

- In remodeling, if necessary, add studs at each end to provide a vertical nailing surface for the side nailing flanges of bath fixture product.
- To avoid obstructions during installation make sure that supply lines, spout pipe and valve plumbing do not project into alcove.
- Shower unit requires a 4" x 14" (102mm x 356mm) recommended floor opening for the 1 1/2" (38mm) drain.
- Be sure floor opening location matches shower unit fixture drain location.
- The shower unit must be supported from the bottom deck.

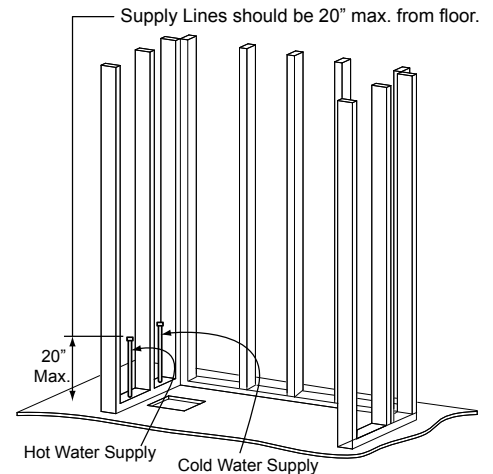

Sub floor

- 1 Prepare the sub floor for the drain and ensure that the area is level. The drain of the shower unit extends below the bottom deck. Identify the drawing in the Technical Specification that corresponds with your shower unit.
- 2 The shower unit must remain level in order for it to drain properly and must make contact with the sub floor.
- 3 Floor must support seventy five pounds (75 lbs) per square foot load.

Installation Procedure

- 1 Make sure framed-in alcove is of proper size per Jacuzzi Luxury Bath dimensions, square, and plumb; check floor for levelness (Fig. 1). Rough-in should be kept to a minimum until the unit is on the job site. Measurements may vary +0 or - $\frac{3}{8}$ " from original specifications. *Note: If back studs are not level and are leaning forward (Fig. 1), it may be necessary to shim the back flange of the shower base (Fig. 3).*
- 2 Pre-Install Shower Base into alcove. Level and mark all sides (Fig. 2). Remove Shower Base after leveling and marking sides.
- 3 Install Drain Assembly (included in accessory kit) per manufacturer's instructions (Fig. 3).
- 4 Tap down until previously marked lines are visible and in line with the nailing flange (Fig. 4).

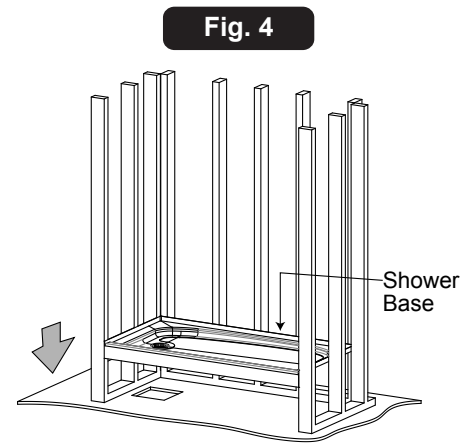
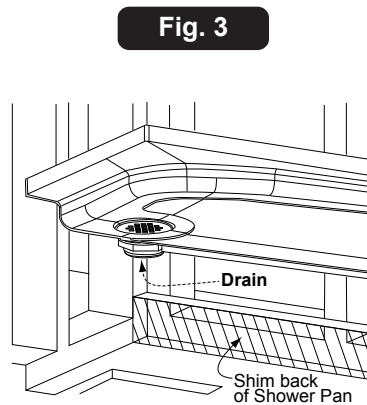
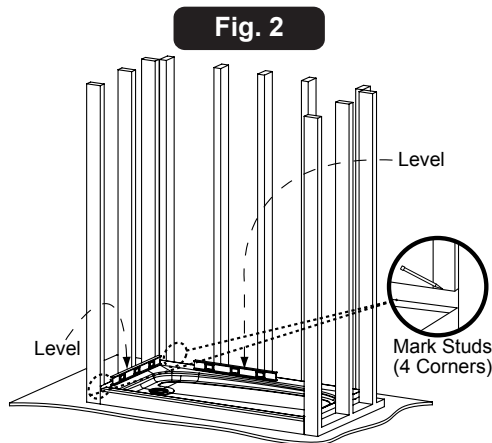
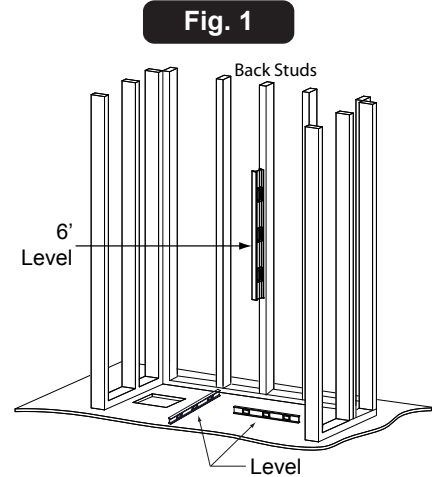

- 5 Pre-drill horizontal nailing flanges along top of Shower Base and fasten into each corresponding stud. Shim if necessary (Fig. 5).
- 6 Lift and place Back Wall. Level vertically and horizontally. Shim if necessary (Fig. 6). *Note: If back studs (Fig. 1) are leaning backwards, shim back wall of shower as necessary.*
- 7 Pre-drill horizontal nailing flanges along top of shower Back Wall and fasten into each corresponding stud. Pre-drill both vertical side nailing flanges and fasten to side studs (Fig. 7). *NOTE: It may be necessary to add horizontal stringers to fasten side wall if stud is not within reach.*

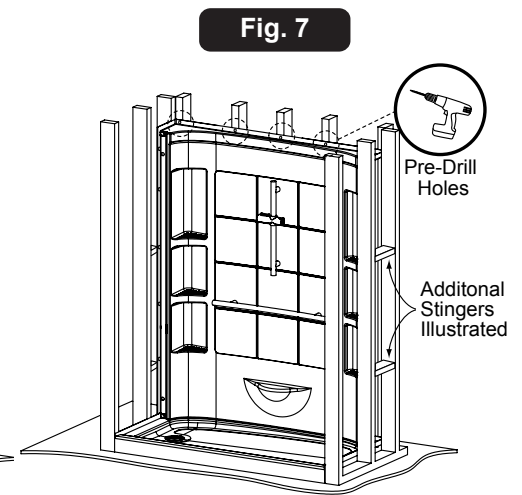
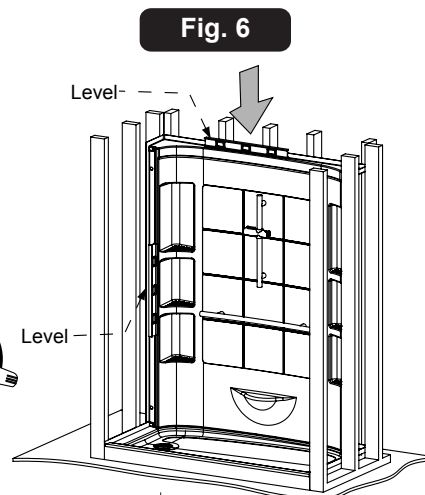
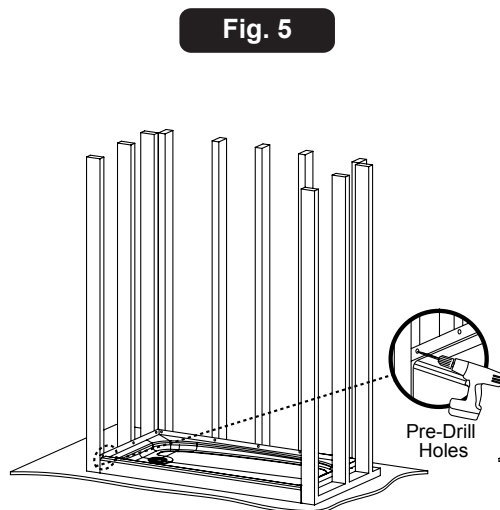

Installation Procedure (Continued)

- 8 Install Gaskets (included in Accessory Kit) along the Back Wall Flange of the Shower enclosure on both sides as illustrated (Fig. 8). Peel off the adhesive tape protector, then locate and install the Gasket approximately at the radius as shown (Fig. 9). The Gasket shall extend along the entire height of the Back Wall. Cut off any excess Gasket material to make the Gasket flush with the top finished radius edge of the Shower enclosure.

Fig. 8

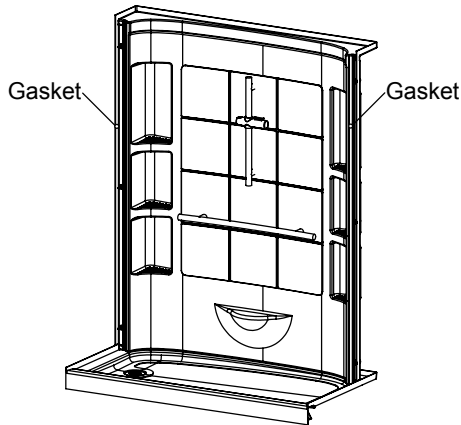

Fig. 9

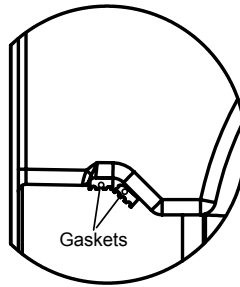
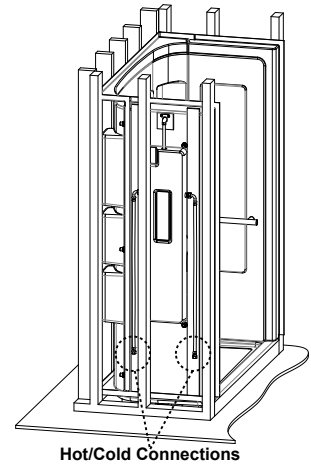

Fig. 10



- 9 Make sure that the hot/cold connections are connected to the supply lines (Fig. 10). Turn water supply on and test unit for any leaks. Slide left Side Wall into position (Fig. 11). Ensure that the pin and receptor engages and you hear a "click" sound (Fig. 12). Check for level.
- 10 Pre-drill horizontal nailing flanges along top of the Side Wall and fasten into each corresponding stud. Pre-drill both vertical side nailing flanges and fasten to side studs at 8" on centers (Fig. 13). *NOTE: A Seal Gasket is provided along the Back Wall sides to provide a seal between the Side Walls and the Back Wall. To ensure proper seal, there should be no visible gap between the mating surfaces of the walls (Fig. 14).*

Fig. 11

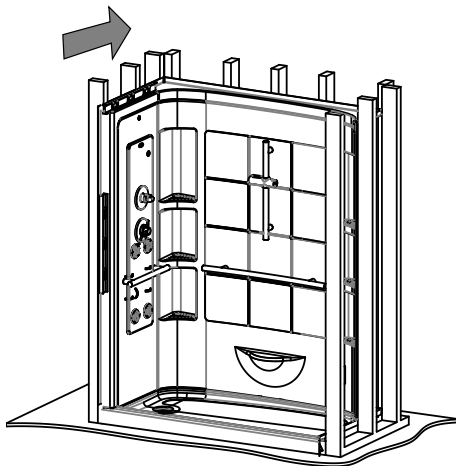

Fig. 12

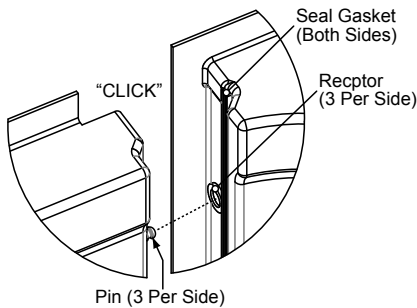
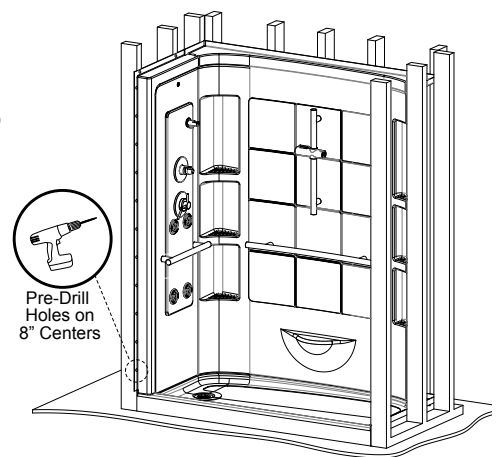

Fig. 13



Installation Procedure (Continued)

- 11 Slide right Side Wall into position (Fig. 15). Ensure that the pin and receptor engages with a “click” sound (Fig. 12). Check for level.
- 12 Pre-drill horizontal nailing flanges along top of shower right Side Wall and fasten into each corresponding stud. Pre-drill both vertical side nailing flanges and fasten to side studs at 8” on centers (Fig. 15). *NOTE: A Seal Gasket is provided along the Back Wall sides to provide a seal between the Side Walls and the Back Wall. To ensure proper seal, there should be no visible gap between the mating surfaces of the walls (Fig. 14).*

Fig. 14

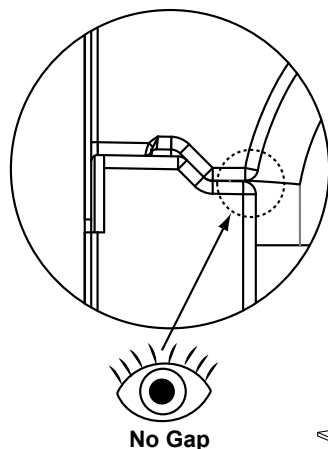

Fig. 15

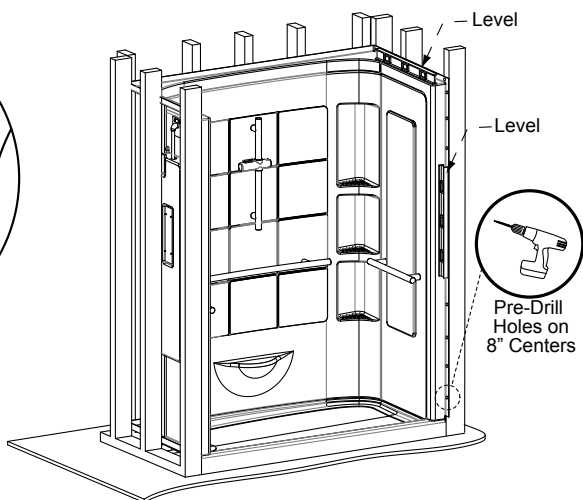
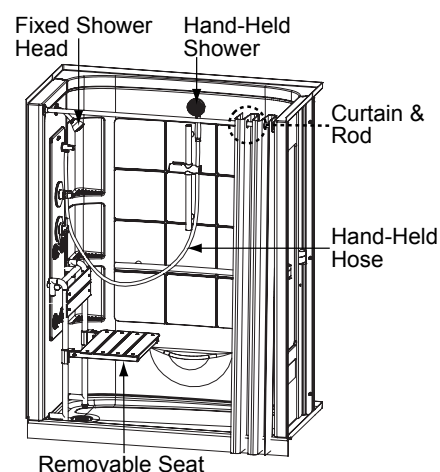

Fig. 16



Included Accessories

Your shower unit shall be equipped with the following standard accessories.

Package A & C Units (Fig. 16)

- Fixed Shower Head
- Hand-Held Shower and Hose
- Curtain, Rod, and Rod Mounting Brackets

Package A Units Only (Fig. 16)

- Repositionable Seat Assembly

Accessory Installation Instructions

Fixed Shower Head Installation

- 1 Look in your accessory kit and locate the included Shower Arm, Escutcheon Plate and Shower Head
- 2 Wrap five layers of Teflon plumber's tape in a clockwise motion around the male threaded end of the Shower Arm to be secured to the pipe in the shower wall. Pull the Teflon tape lightly against the threads to prevent leaks.
- 3 Screw the taped end directly onto the pipe elbow inside the shower wet wall by turning it clockwise. It should take about two turns. Slide the provided Escutcheon Plate in place over the Shower Arm.
- 4 Wrap several layers of Teflon tape around the male threads on the opposite end of the Shower Arm. Install the provided Shower Head onto the taped threads. Turn the Shower Head clockwise about one-half turn with a wrench then test for leaks. If leaks are present, turn the Shower Head an additional one or two turns to stop the leak.

Accessory Installation Instructions (Continued)

Hand-Held Shower Installation

- 1 Look inside your accessory kit and locate the included Flexible Hose and Hand-Held Shower.
- 2 Wrap about five layers of Teflon plumber's tape in a clockwise direction around the male threaded end of the shower elbow mounted on the wet wall. Pull the Teflon tape lightly against the threads to prevent leaks. Screw the end of the Flexible Hose directly onto the male threaded end of the Shower Elbow by turning it clockwise (Fig. 17).
- 3 Wrap several layers of Teflon tape around the male threads of the Hand-Held Shower. Screw the other end of the Flexible Hose directly onto the threaded end of the Hand-Held Shower by turning it clockwise (Do not overtighten).
- 4 The Hand-Held Shower can be positioned on the Back Wall Slider/Holder (1) or on the fixed Holder (2) located on the wet wall (Fig. 17).

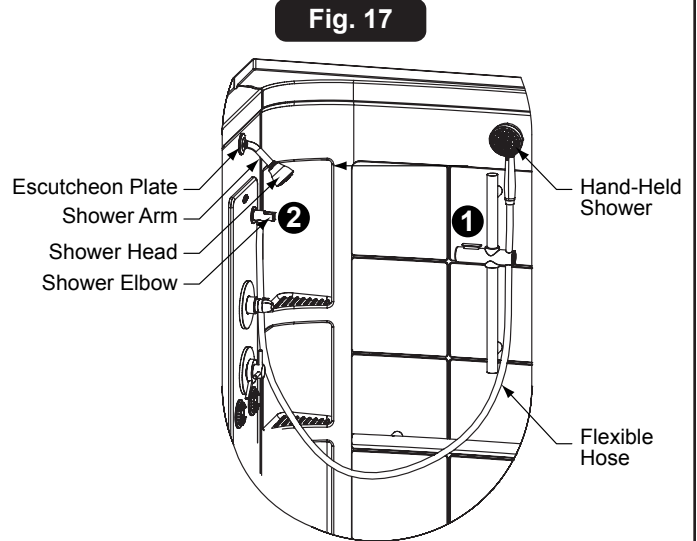

Curtain Rod Installation

- 1 Look in your accessory kit and locate the included Curtain, Shower Rod and Mounting Brackets.
- 2 Using a helper, position the Shower Curtain Rod with Mounting Brackets at each end at the recommended height as illustrated (Fig. 18). Verify the rod is level, then use a pencil to mark the Mounting Brackets drill holes. Double-check the Mounting Brackets and Shower Curtain Rod for level by checking the distance of each Mounting Bracket to the back wall and floor (adjust and remark if necessary).
- 3 Drill pilot holes into the marked left and right Mounting Bracket hole positions using a 1/8" drill bit. Place either the left or right Mounting bracket over either drilled location, then line up the Mounting Bracket holes with the underlying pilot holes. Drill the supplied installation kit screws through the aligned bracket holes into the wall. **DO NOT OVERTIGHTEN.**
- 4 Slide the provided Shower Rod into the installed Mounting Bracket, then install the remaining Mounting Bracket onto the opposite end of the Curtain Rod. Position the second Mounting Bracket over the remaining mounting location, then attach it in the same manner as used in step 3. Finally, install the supplied Shower Curtain over the installed Shower Rod to complete the installation.

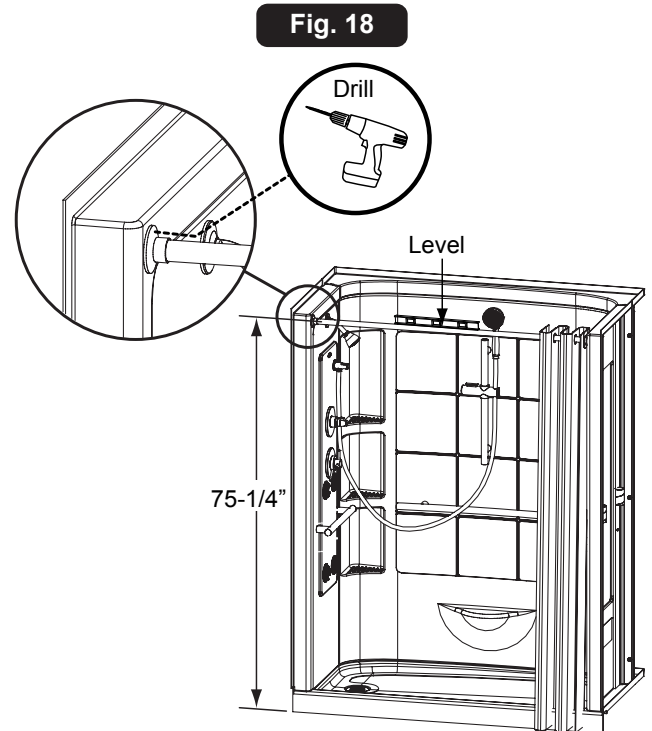

Accessory Installation Instructions (Continued)

Seat Installation (Package A Only)

The seat is removable and repositionable on the left, back or right Side Wall as illustrated (Fig. 19, 20, 21). Refer to the instructions outlined below for details.

Fig. 19

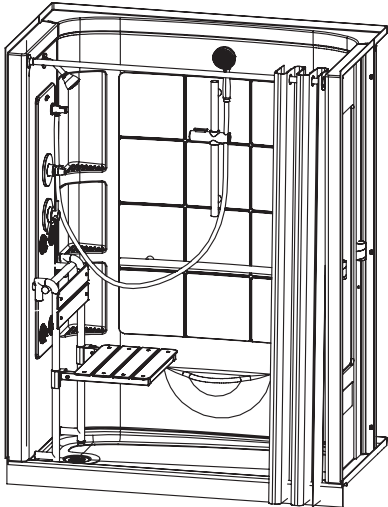

Fig. 20

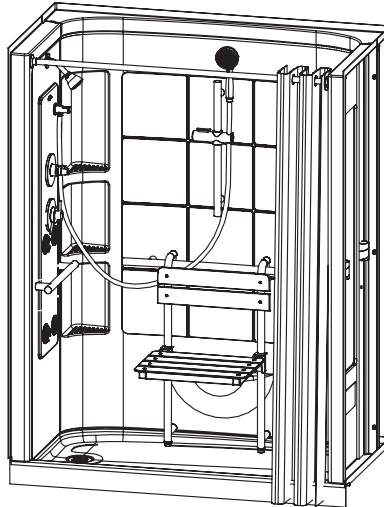
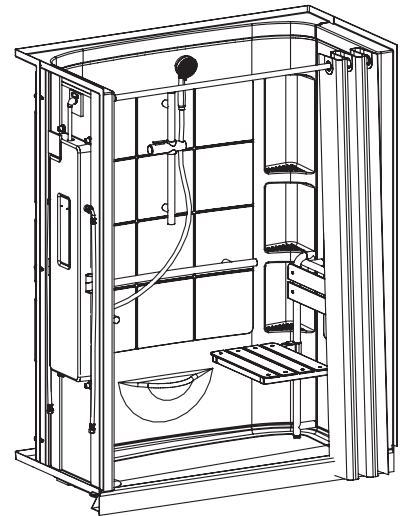

Fig. 21



Determine the desired seat location, then center and slide the Seat Bar over the Grab Bar. Finally, lower the Seat Leveling Pads until each touches the adjacent surface as illustrated (Fig. 22).

CAUTION Never sit on the Seat without first adjusting each of the four leveling pads against their adjacent surface (Fig. 22). Such an action can result in personal injury or damage the shower surface due to uneven weight distribution on the supporting Seat legs.

Fig. 22

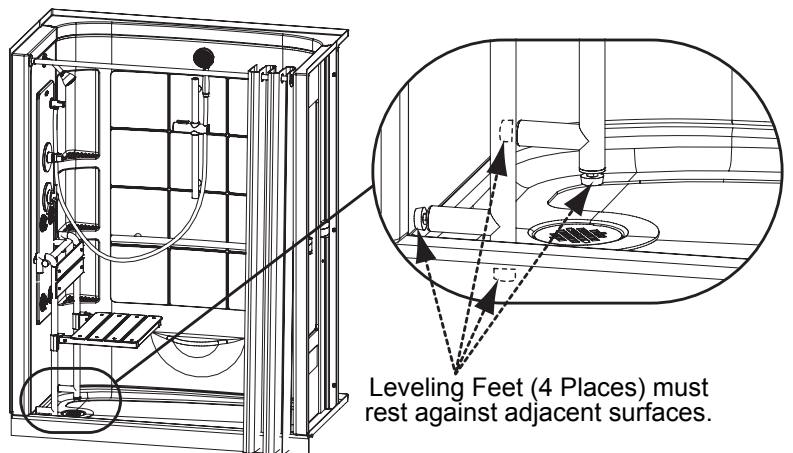

Plumbing Panel Access Instructions

- 1 Using an 1/8" Allen Wrench, remove the set-screw located on the underside of the Grab Bar (2-locations), then pull the Grab Bar outward to remove (Fig. 23).
- 2 Remove the Diverter and On/Off Knob Caps and save for reuse (Fig. 24). Loosen the Set Screw for each knob 1 turn using a 3/32" Allen Wrench, then unscrew each knob by turning it counter-clockwise. Remove the On/Off knob by pulling outward at the knob base, then remove the underlying Bushing. Remove the Diverter Knob by pulling outward at the knob base.
- 3 Remove the Thermostatic and Diverter Valve Escutcheon Plates, then unscrew and remove the Collar Nut from the Diverter/On/Off Valve Assembly (Fig. 24). Carefully pull outward on the Panel. *Note: The panel is secured by locking pins on 4 corners.* **WARNING: DO NOT** pull the Panel outward beyond the length of underlying hoses. To reinstall Panel, simply repeat steps in reverse order.

Fig. 23

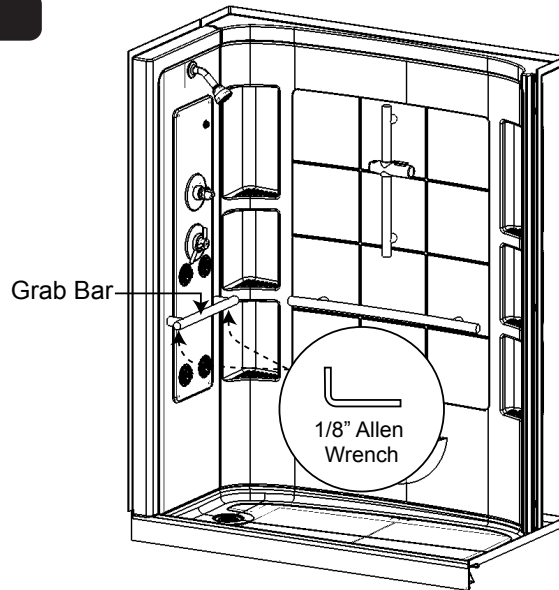
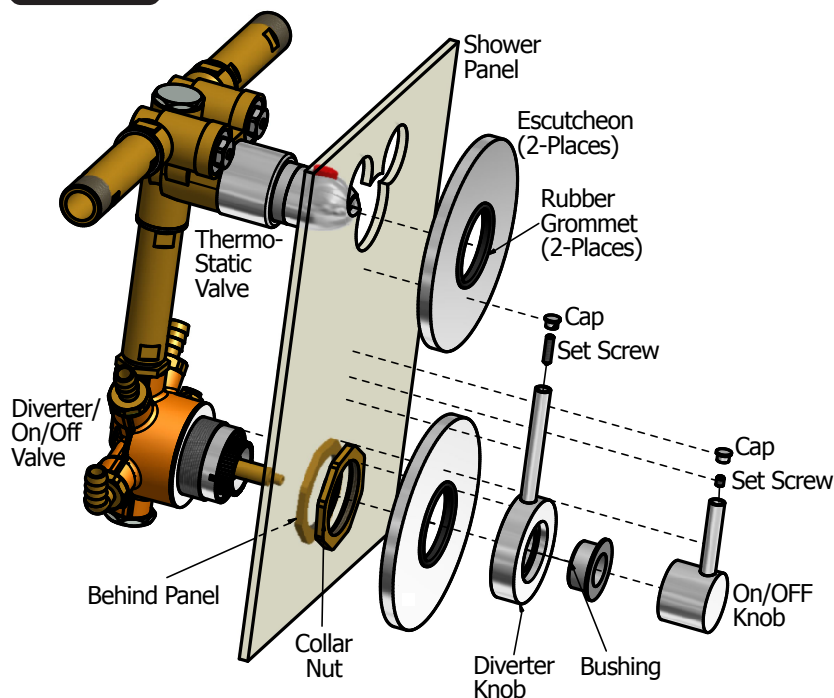
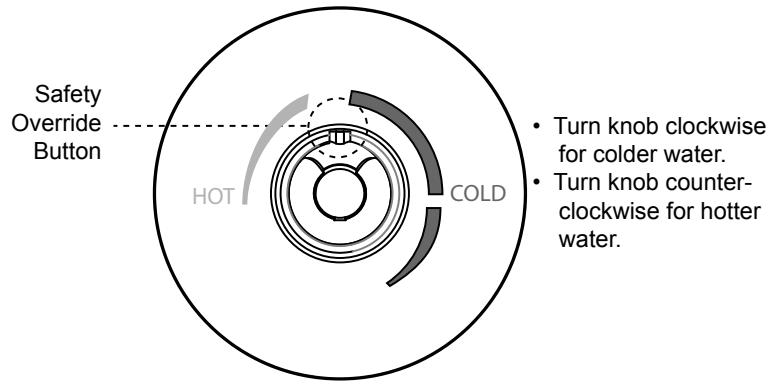

Fig. 24



Controls



Thermostatic Valve

- Turn knob clockwise for colder water.
- Turn knob counter-clockwise for hotter water.

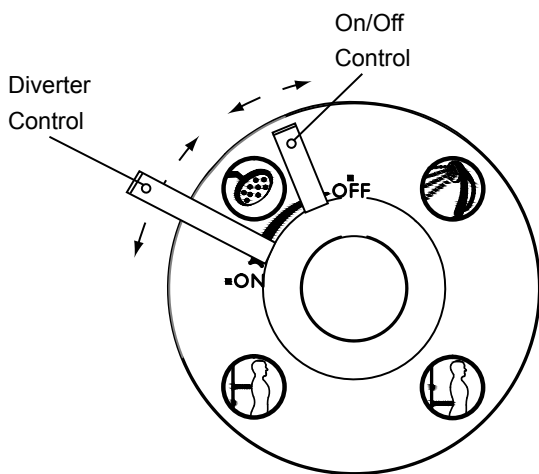

4-Port Diverter Valve
(For Package A Units Only)

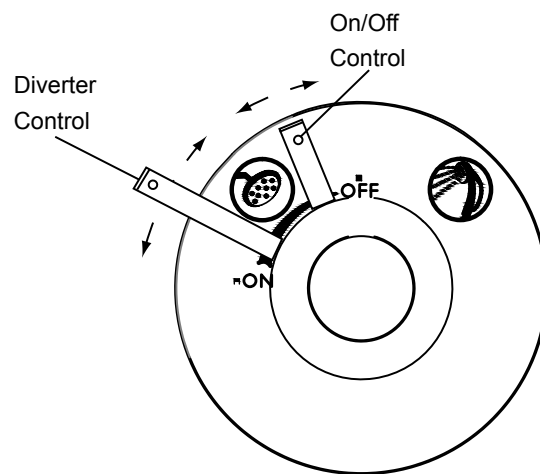

2-Port Diverter Valve
(For Package C Units Only)

Maintenance

To clean your Shower unit, simply use a mild, non-abrasive liquid detergent solution (solution must be safe for acrylic surfaces). You can protect and restore the gloss to a dulled acrylic surface by applying Meguiar's #10 Mirror Glaze, a product specifically designed for use on acrylic finishes. If Meguiar's is not available, use a fine grade automotive rubbing compound followed by an application of clear automotive paste wax.

Minor scratches which do not penetrate the color finish can be removed by lightly sanding with 600-grit wet/dry sandpaper. Restore the gloss using Meguiar's Mirror Glaze or automotive paste wax. Major scratches and gouges which penetrate the acrylic surface will require refinishing. Call Jacuzzi Luxury Bath to find a service agent in your area.

Authorized Service

If you need a referral for a service company near you, or need assistance with operation or maintenance-related questions, please call our Service Support Department at 1-800-288-4002. Visit our web site at <http://www.jacuzzi.com/> for products, services, and an online copy of these Installation and Operation Instructions.

When requesting service or technical assistance please have available both the model and serial number of your unit. This information can be obtained from the product registration card provided with your unit. If the card has been misplaced, this information can be obtained from the specification/serial number label on the unit itself. The label is located on the wall of the shower unit near the thermostatic & diverter valves.

SPECIFICATION/SERIAL NUMBER LABEL

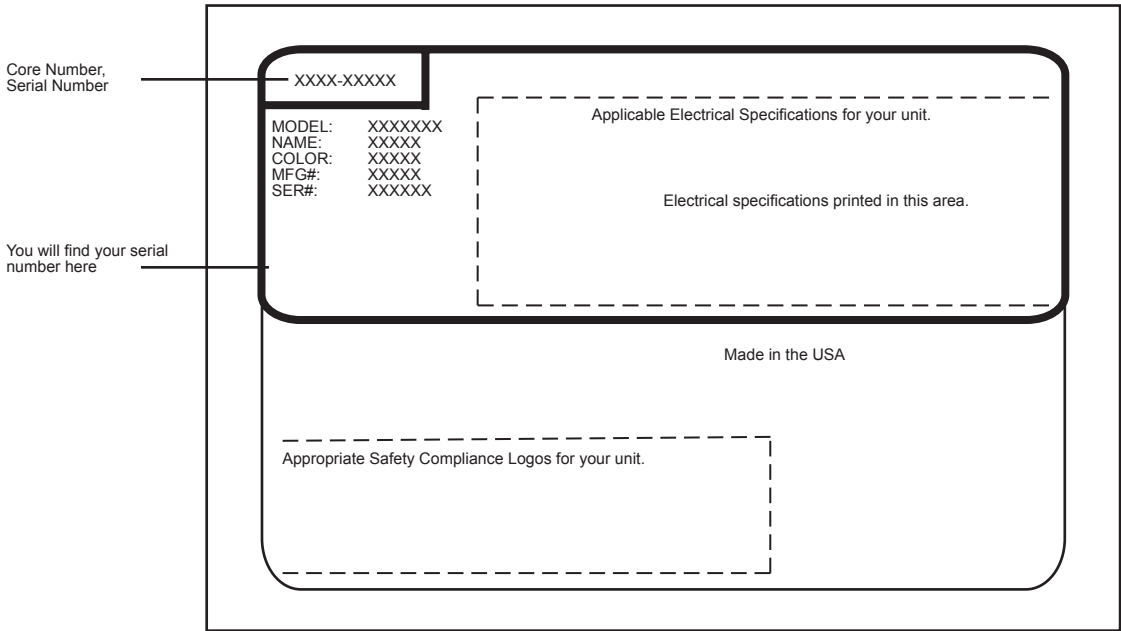

PRODUCT SPECIFICATIONS ARE SUBJECT TO CHANGE WITHOUT NOTICE.
USE TECHNICAL SPECIFICATIONS MANUAL SUPPLIED WITH PRODUCT.

Jacuzzi Luxury Bath has obtained applicable code (standards) listings generally available on a national basis for products of this type. It is the responsibility of the installer/owner to determine specific local code compliance prior to installation of the product. Jacuzzi Luxury Bath makes no representation or warranty regarding, and will not be responsible for any code compliance.

Jacuzzi® Luxury Bath
14525 Monte Vista Avenue
Chino, California, 91710
1-800-288-4002
www.jacuzzi.com

Limited Warranty on Jacuzzi® Branded Walk-in Shower

WARRANTY COVERAGE

Jacuzzi Luxury Bath ("Company") offers the following limited warranty to the original purchaser of a Jacuzzi® branded Walk-in Hydrotherapy Shower ("Shower"), for personal or single family residential use ("user"):

DURATION & COVERAGE-Company provides the following warranty against defects in material and workmanship, subject to the term, conditions, limitations and exclusions set forth herein. All time periods commence on the original date of purchase.

Component	Duration for Defects in Material and Workmanship	Labor
Acrylic shower walls and shower pan against blistering, cracking, or delaminating (see exclusions below)	Lifetime	1 Year
-Factory installed valves -Factory installed plumbing	1 Year	1 Year
Grab bars & seat	1 Year	No Labor Warranty
Jets	90 Days	90 Days
-Mounting hardware -Handheld shower wand, hose, showerhead, drain, shower curtain & rod -Factory installed components not specifically mentioned above	90 Days	No Labor Warranty

The above periods are subject to the terms, conditions and limitations set forth below. The Company will repair or replace, at its sole option, the Shower or its component parts in accordance with the terms, conditions and limitations set forth in this limited warranty. Units in commercial use are excluded from any warranty coverage whatsoever. PLEASE READ THIS ENTIRE LIMITED WARRANTY, AS EXCLUSIONS AND CONDITIONS APPLY.

LIMITED WARRANTY ON SHOWERS

The Company extends to the original user of the Shower and its component parts a non-transferable limited warranty for the applicable periods set forth in the chart above. These warranty coverages do not cover defects or water loss due to installation and/or assembly of the Shower or any component, or the sealing of any component, which is not performed by Company. The components referenced above and coverage of this warranty are for defects in material or workmanship, and not damage caused by installation, neglect, misuse, abuse, or failure to follow the instructions and warnings set forth in the owner's manual, including but not limited to cleaning of the Shower and its component parts. This warranty does not apply to any display models or to any options or accessories not specifically mentioned herein. Warranty coverage begins on the date the unit was originally purchased by the user.

LABOR WARRANTY FOR FACTORY INSTALLED COMPONENTS

The Company provides a limited labor warranty for the applicable period set forth in the chart above, which commences on the date the unit was originally purchased by the user. This labor warranty is subject to the limitations set forth below.

EXCLUSION OF IMPLIED WARRANTIES, WARRANTY LIMITATIONS AND EXCLUSIONS

IMPLIED WARRANTIES OF MERCHANTABILITY AND FITNESS FOR A PARTICULAR PURPOSE ARE DISCLAIMED ALTOGETHER OR TO THE FULLEST EXTENT ALLOWED BY LAW. This Limited Warranty takes the place of all other warranties, express or implied, in fact or at law, including implied warranties of merchantability and fitness for a particular purpose. All warranty service must be performed by Company or its designated representative using authorized Jacuzzi® parts. Company reserves the right to use replacement parts that may be different from the part(s) that accompanied the original Shower, including but not limited to different in appearance, configuration, performance and/or structure. No agent, dealer, distributor, service company or other party is authorized to change, modify or extend the terms of this limited warranty in any manner whatsoever. The limited warranty does not cover defects, damage, or failure caused by common carrier, installer, user, or other persons, pets, or rodents, or resulting from, without limitation, any of the following: careless handling (e.g., improper lifting of the unit by the plumbing, abrading finish, etc.) including negligence of any party; modification of any type for any reason (including modification to meet local codes); improper installation (including installation not in accordance with instructions and specifications provided with the unit); connections made by the installer of the Shower or any component; misuse; abuse; incorrect operation, or lack of proper routine maintenance; operation of the unit at inappropriate water temperature; use of abrasive or improper cleaners; or acts of God, such as lightning, floods, earthquakes, etc. In addition, THE COMPANY WILL NOT BE RESPONSIBLE FOR INCIDENTAL OR CONSEQUENTIAL DAMAGES or losses arising from any cause (e.g., water damage to carpet, ceiling, tiles, marble, loss of use, etc.) including but not limited to its own negligence; damages to, respecting, or resulting from: plated parts when chemicals or cleaning products are used on the Shower; hard water conditions; optional Shower equipment not manufactured by the Company but supplied by a dealer, installer or the Company; the unit's prior usage as an operational display; or defects that should have been discovered before installation. This exclusion applies even if Company was advised in advance of the possibility of such damages. This limited warranty does not include: labor, transportation, or other costs incurred in the removal and/or reinstallation of the original unit and/or installation of a replacement unit; any costs relating to obtaining access for repair; or loss of use damage, including loss of sales, profit or business advantage of any kind under any circumstances. Shower units are excluded from any warranty coverage if any addition, deletion, or modification of any kind whatsoever has been made to the unit (or to any component). Warranty coverage is provided in the United States of America, Canada and Mexico only. The liability of Company under this limited warranty, if any, shall not exceed the original amount paid for the Shower or product claimed to be defective. Dated proof of purchase of Shower or product is required for a warranty claim. These disclaimers shall be equally applicable to any service provided by Company and its designated representatives.

WARRANTY REGISTRATION

To register your product, please go to our website <http://www.jacuzzi.com/baths/>, then select Warranty Registration at the bottom of the page. You will then be prompted to enter your product Serial Number followed by your warranty registration information. You may also register the warranty by completing the registration card provided with your product and mailing it to the Company at the address provided below. The warranty must be registered online or by filling out and returning to the Company the Warranty Registration card within thirty (30) days from the date of purchase in order for this warranty to become effective.

RESPONSIBILITIES OF OTHERS

Inspecting the unit prior to installation is the responsibility of the user, as well as the installer or building contractor who acts on behalf of the user. They are responsible for ensuring the unit is free of defect or damage. Notices are placed on and in the unit and on the shipping carton advising the installer of this responsibility. In the event of a problem, the unit must not be installed. The Company is not responsible for failures or damage that could have been discovered, repaired, or avoided by proper inspection and testing (including proper water testing) prior to installation. Damage occurring in transit is the responsibility of the carrier. The user or installer MUST open the crate and inspect the unit for damage when it is delivered. If damage is discovered, it must be reported immediately to the seller and the carrier in writing, and an inspection requested. Failure of the carrier to respond should be reported to the seller and the carrier. Your freight claims should be filed promptly thereafter. Damage occurring to the unit during installation is the responsibility of the installer, building contractor and/or user, and damage occurring thereafter is the responsibility of the user. Failure of any optional equipment is the sole responsibility of the equipment manufacturer except as provided above and shall not extend to or apply to any replacement parts for the options and accessories. Any replacement parts shall be covered only by the original equipment manufacturer warranty, if any. The distributor, dealer and user are responsible for knowing local code requirements and notifying the installing contractor of these requirements at the time of purchase. The Company is not responsible for costs to modify any product to obtain any code approval, such as city, county, or state building codes in U.S.A. or federal, municipal, provincial or other codes in Canada and Mexico.

WARRANTY SERVICE

For the user's benefit, the Company maintains a list of independent service personnel to perform required warranty service repairs. Such firms are not agents or representatives of the Company and cannot bind the Company by words or conduct. The Company will provide the warranty service described above when the following conditions have been met: the failure is of the nature or type covered by the warranty; the user has informed an Authorized Jacuzzi Luxury Bath Service Agent or Warranty Service Department Representative of the nature of the problem during the warranty period; conclusive evidence (e.g., proof of purchase or installation) is provided to the foregoing by the user proving that the failure occurred or was discovered within the warranty period; and, an authorized independent service person or Company representative has been permitted to inspect the unit during regular business hours within a reasonable time after the problem was reported by the user. In order to obtain warranty service, contact Jacuzzi Luxury Bath at:

www.jacuzzi.com or
Warranty Service Department
14525 Monte Vista Avenue
Chino, California 91710
Call: (800) 288-4002

To obtain warranty replacement for factory installed components or Company supplied options and accessories manufactured and supplied by the Company, call or write the above. Provide a description of the problem and proof of purchase. You will be instructed how to obtain replacements and where to return, at your expense, the failed component(s), option(s), or accessory(ies).

All replacement parts, equipment, and repairs shall assume the remaining warranty period of the part(s) replaced.

The Company's warranty obligation shall be discharged upon tender of replacement or repair. The customer's refusal to accept the tender terminates the Company's warranty obligation.

LEGAL RIGHTS: This Limited Warranty gives you specific legal rights. There are no warranties applicable to Jacuzzi® products except as expressly stated herein or as implied by applicable state and federal laws. You may also have other rights that vary from state to state. Some states do not allow limitations on how long an implied warranty lasts, disclaimer of certain warranties, or the exclusion or limitation of incidental damages, so some of the above limitations may not apply to you. Company will not be responsible for any statements or representations made in any form that go beyond, are broader than or are inconsistent with any authorized literature or specifications furnished by the Company.

Ninety-Day
Parts Only
Limited Warranty
On
Accessory(ies)



Jacuzzi® Luxury Bath
14525 Monte Vista Avenue
Chino, California 91710



WARRANTY REGISTRATION CARD

To complete your registration, visit our website at www.jacuzzi.com or fill out and mail this card to the address printed on the other side within thirty (30) days from date of purchase in order for this warranty to be come effective.



Purchaser's Name _____
Purchaser's Address _____
City _____ State __ Zip _____
Home Phone: _____ Cell Phone: _____
Email: _____
Date of Purchase _____
Model Name _____
Serial Number _____
Dealer's Name _____
Dealer's Address _____

- 1. How did you first hear about this Jacuzzi® product?
2. Who first gave you specific information about this product (specifications, prices, etc.)?
3. What was the main reason for purchase?
4. Who finally decided which product you would buy?
5. Who installed?
6. What is the current market value of this property?
7. What is the age of the head of the household?
8. What other manufacturers did you consider?
9. How long did you shop before purchasing unit?
10. Approximately how long have you lived in this home?
11. Please indicate, approximately, the total annual income of your household.
12. Was your purchase process?
13. How technically aware were you of the patented Jacuzzi® jet system prior to your purchase?

Ninety-Day
Parts Only
Limited Warranty
On
Accessory(ies)