

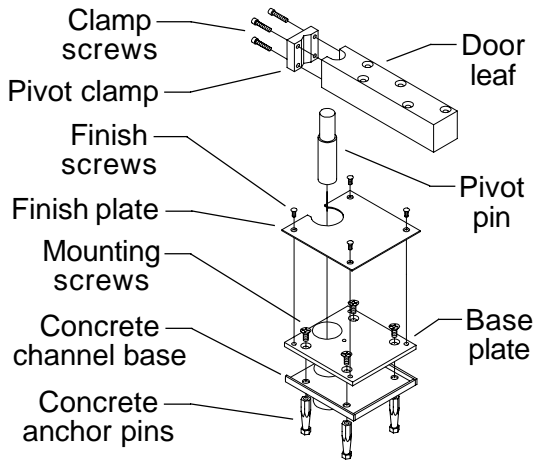

Installation Instructions

7259

Bottom Center Pivot



NOTE
2" minimum door thickness.

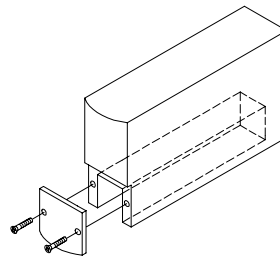

Figure 1

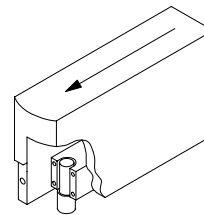

Figure 2

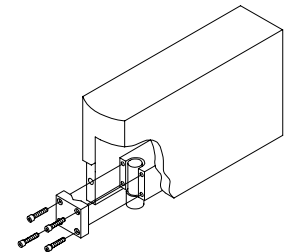

Figure 3

1. Prepare and mortise bottom of door and floor to receive pivot set. Determine pivot location using dimensions on reverse side. **Be sure to properly locate base plate.** The finish plate of pivot base assembly should be removed until installation is complete.
2. Prepare bottom of door. If bottom of door has not been prepared prior to pivot installation, mortise per dimensions on reverse side. The bottom of the door must have a removable heel section (Figure 1).
3. Remove pivot clamp from door pivot leaf with 5/16" Allen wrench. Locate, drill, and tap mounting holes for door leaf. Mount door leaf in bottom of door with screws provided.
4. Locate and prepare cutout in floor for pivot base. **The pivot base assembly must be located so that the center line of top pivot point is plumb with center line of base pivot point.** Secure pivot base:
 - A. Prepare compound that will be used to fill around pivot base (concrete, cement, grout, etc.).
 - B. Fill cutout with compound, leaving room for concrete channel base to fit flush with floor.
 - C. Set pivot base into cutout. Align base assembly so pivot point is in proper position.
 - D. Use a level to be sure pivot base assembly is level on all sides.
 - E. Secure in proper position until compound sets up completely. Once compound has set up, mounting screws can be removed, allowing removal or replacement of pivot base assembly.
 - F. Re-attach finish plate.
5. Maneuver door into position, about 90° to frame. Position door so door pivot leaf mates with pivot pin as shown in Figure 2. Re-attach pivot clamp as shown in Figure 3. Do not tighten clamp screws completely. Engage pivot leaves at top of door. Now tighten clamp screws securely.
6. If height adjustment is necessary for proper clearance, use shims between door bottom and pivot leaf to increase clearance. To decrease clearance, mortise in door must be made deeper.



CAUTION

Improper pivot set installation can lead to personal injury or property damage. Follow all instructions carefully. For questions contact Technical Support at 1-888-371-7331.



NOTE

It is very important for installer to verify that center line of top pivot point lines up with center line of bottom pivot point before final installation.

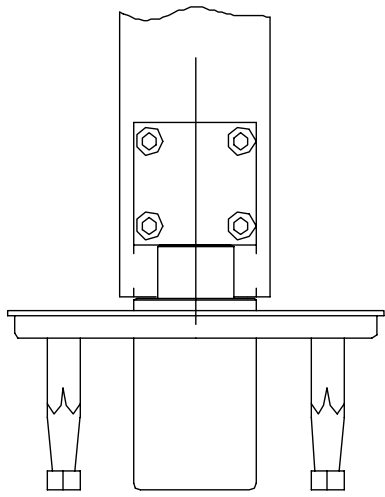
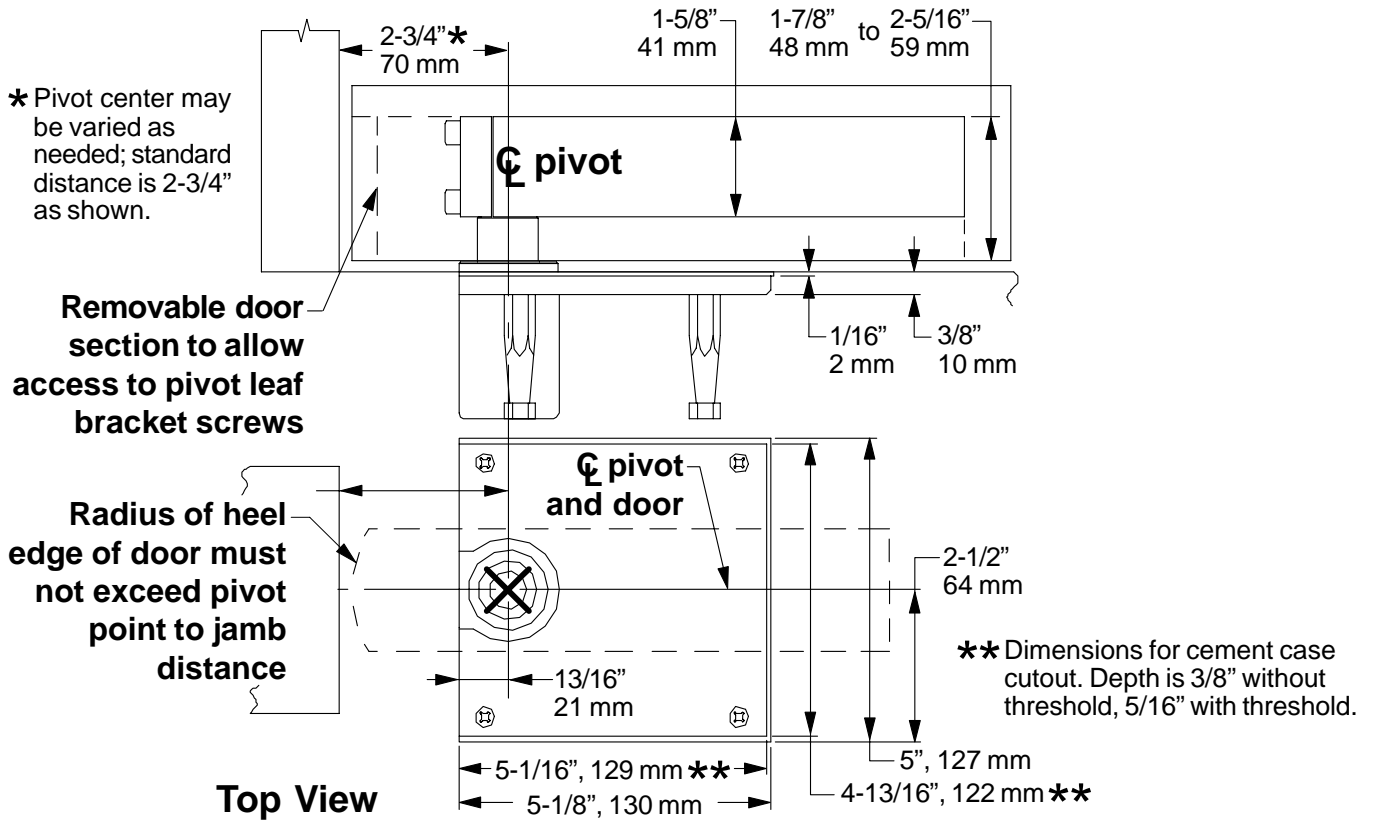

End View without Threshold

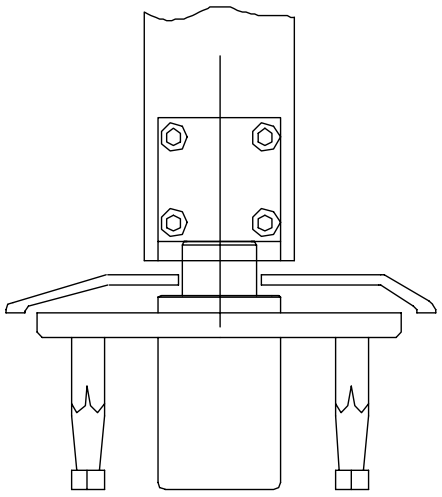

End View with Threshold

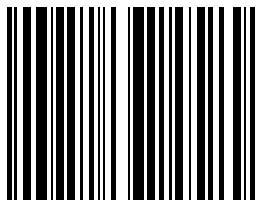

26633