

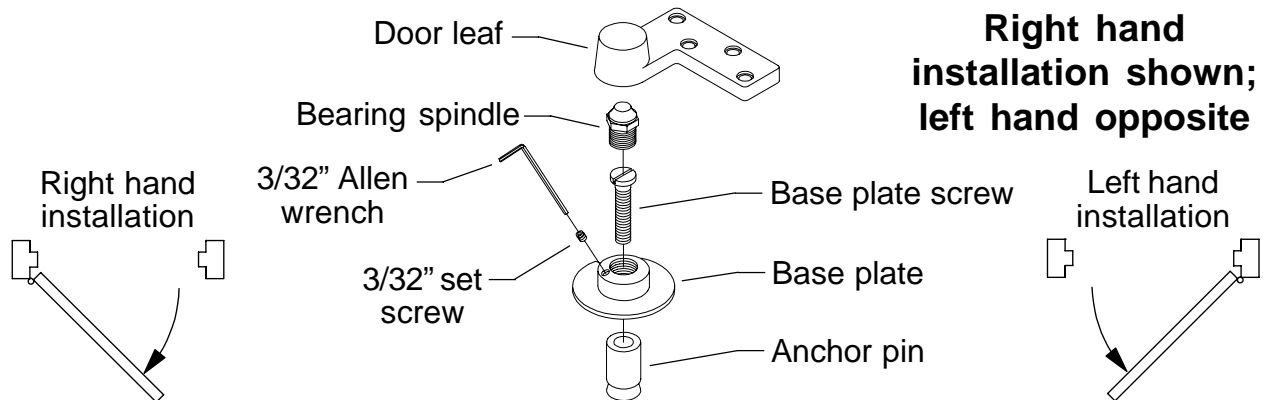

Installation Instructions

7222

3/4" Offset Bottom Pivot



1. Prepare and mortise bottom of door and floor to receive pivot set. Determine pivot location using dimensions on reverse side. **Be sure to properly locate and mark pivot center point of the base plate.** The bottom pivot set is handed. Hand of pivot set must match hand of door. To determine hand of door, see diagrams above.
2. Locate, drill, and tap 1/4-20 mounting holes for metal door. Locate and drill pilot holes for #14 wood screws for wood door. Mount door leaf in bottom of door with 1/4-20 x 3/4" FHMS or #14 FHWS screws.
3. Drill 3/4" dia. x 1-3/4" deep hole in floor on center of pivot point for base plate mounting. Insert anchor pin and expand with tool. Insert base plate screw provided. Grout anchor pin in place. After grout has set, remove base plate screw.
4. Place base plate over anchor pin. The notch in base plate is to clear corner of frame. Fasten to floor with base plate screw. Tighten securely.
5. Thread bearing spindle all the way into base plate, then back out one full turn. Use Allen wrench to tighten set screw securely, locking bearing spindle in place. If threshold is used, install now.
6. Install top pivot set and hang door. Refer to top pivot set instructions. If height adjustment is required for proper door clearance, adjust bottom pivot as follows:
 - A. Loosen set screw using 3/32" Allen wrench provided (see diagram above).
 - B. Use 5/8" Allen wrench to adjust pivot shaft height as needed. Range is plus 1/4", minus 1/16".
 - C. Tighten set screw firmly.



CAUTION

Improper pivot set installation can lead to personal injury or property damage. Follow all instructions carefully. For questions contact Technical Support at 1-888-371-7331.



NOTE

It is very important for installer to verify that center line of top pivot point lines up with center line of bottom pivot point before final installation. Heel edge of door must be beveled $1/8''$ in $2''$ as shown below.

*Depth of mortise will vary depending upon installation and/or threshold height.

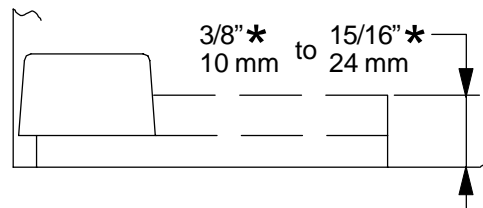

Bevel heel edge of door $1/8''$ in $2''$ with $3/16''$ rad, typ

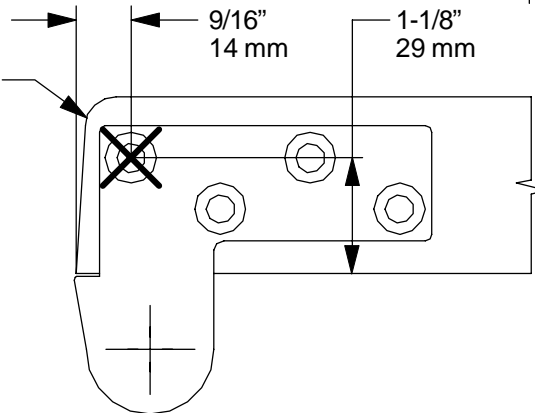

Door Leaf

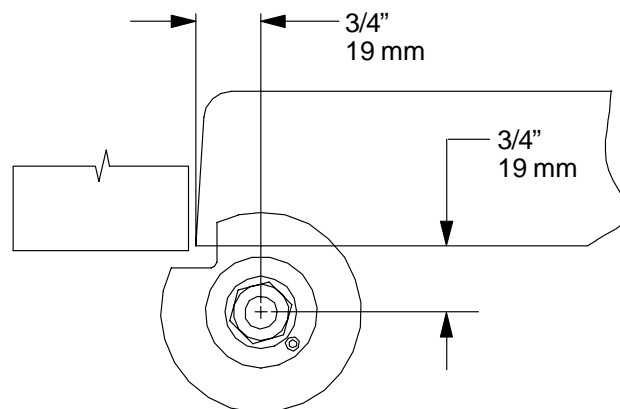

Pivot Base

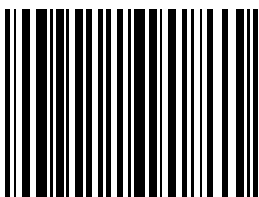

16001