



Iron-A-Way

Managing space with style



Installation Manual

MODEL: UD-42

GET TO KNOW YOUR UNIT

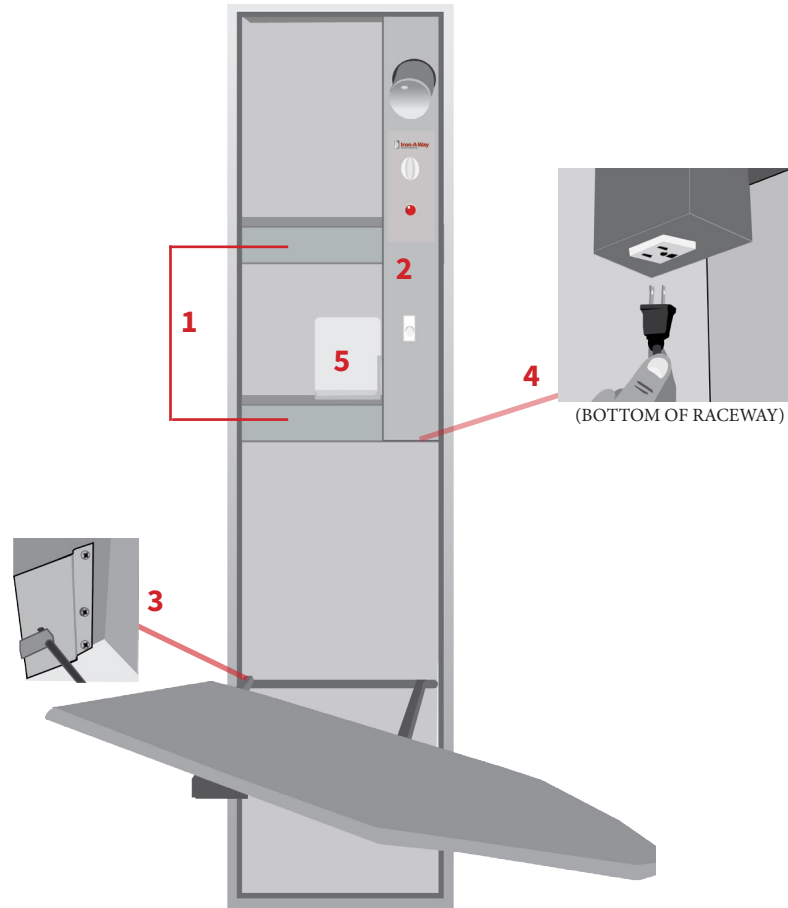

1. CROSS BRACES

4. ELECTRICAL OUTLET

2. ELECTRICAL RACEWAY

5. HOT IRON REST

3. SIDE BRACKETS

Tools Needed:

- Stud Finder
- 12-14" Level
- Tape Measure
- Small Flathead Screwdriver
- Electric Drill (with 1/4" & 1/8" drill bit)
- 1/4" Nut Driver (optional)
- Safety Glasses
- Utility Knife

Supplied Parts:

Recessed Mounting:

- Two #10 x 1 1/2" wood screws for top portion of cabinet
- Two #14 x 2 1/2" Phillips screws for top side brackets

Surface Mounting:

- Two #14 x 4" wood screws

PRE-INSTALLATION

1. DETERMINE MOUNTING HEIGHT

Using the charts provided, determine the mounting height above floor (the distance between the floor and the bottom of the cabinet). First choose your desired ironing board height from the left column, then locate the corresponding mounting height in the right column.

Desired Ironing Board Height	Mounting Height Above Floor
32"	16"
31"	15"
30"	14"
29"	13"

2. LOCATE STUDS & UTILITIES

Using a stud finder, locate the wall studs to be used for mounting.

Locate the existing wiring or other utilities in the wall to prevent drilling into/severing a wire and/or other utility during installation.

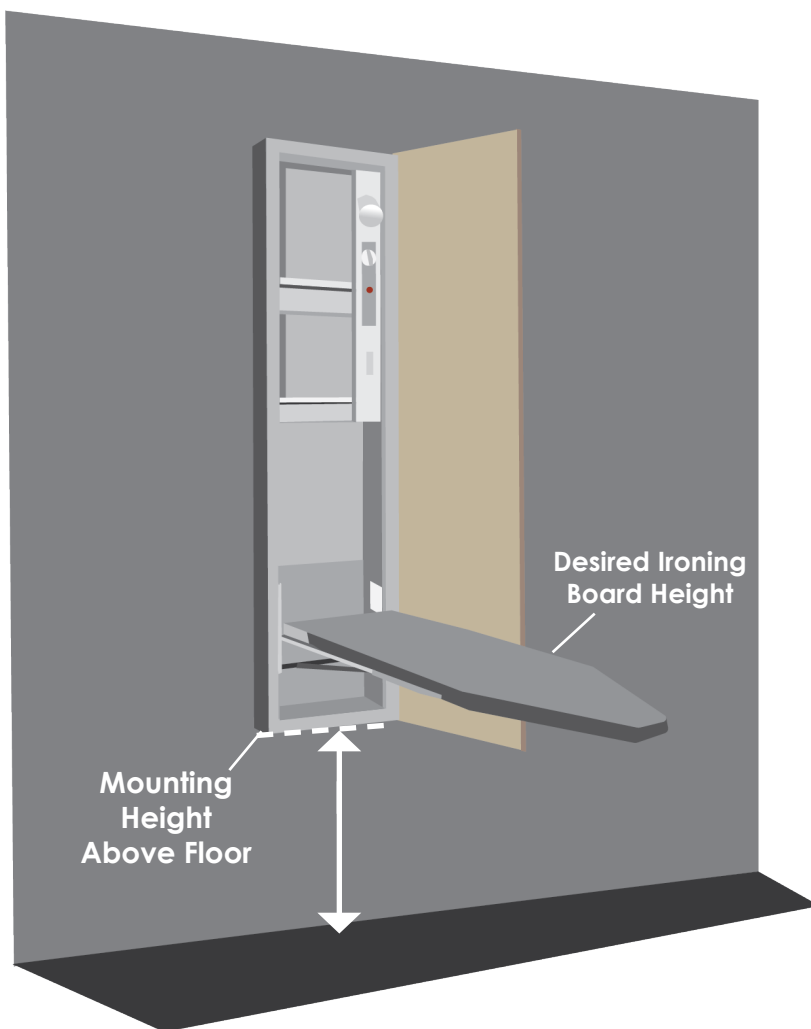

3. ENSURE ADEQUATE SPACE

Refer to provided chart to ensure adequate clearance for ironing. The cabinet door opens at 180 degrees; allow 16" from side of cabinet for door to fully open.

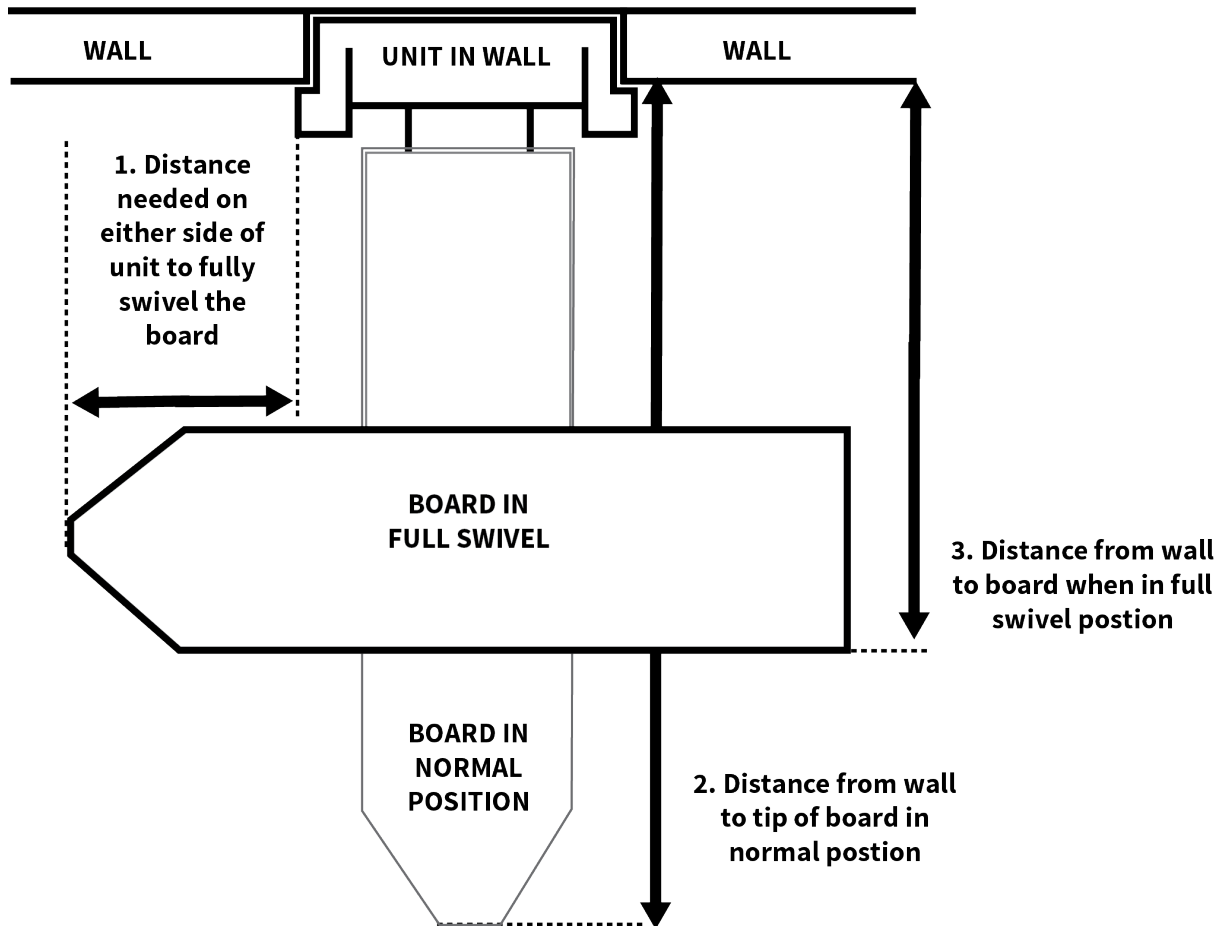

1. Distance needed on either side of unit to fully swivel the board	16^{7/8}"
2. Distance from wall to tip of ironing board	50^{1/4}"
3. Distance from wall to board when in full swivel position	32^{1/4}"
4. Standing area clearance (not shown) <i>The suggested distance from the side of the ironing where the user typically stands to ensure adequate space for ironing.</i>	24"

RECESSED INSTALLATION

Note: Instructions assume wall studs are spaced 16" on center.

1. CUT WALL OPENING

Cut an opening into the wall based on dimensions given below.

14 3/8" x 59 7/8" x 3 7/8"

2. ATTACH CLEATS

Attach a 2" x 4" cross support cleat between the studs so it is level with the bottom of the opening. This will give support to the drywall during installation and to the cabinet once installed in the wall.

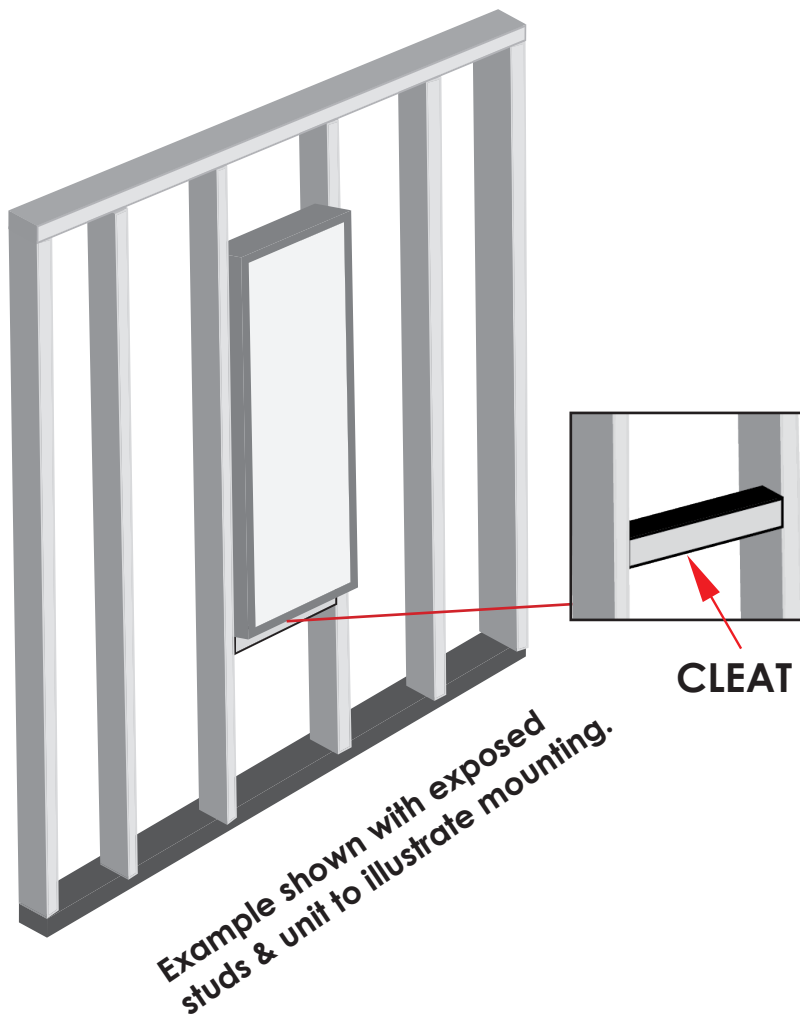

3. PRE-DRILL HOLES

Your unit will be attached to the studs by screws in the upper and lower sides of the cabinet.

Remove electrical raceway by unscrewing the top and bottom screws.

Using a 1/8" drill bit, pre-drill holes into the sides of the cabinet, 14" from the top and 2 1/2" from the back.

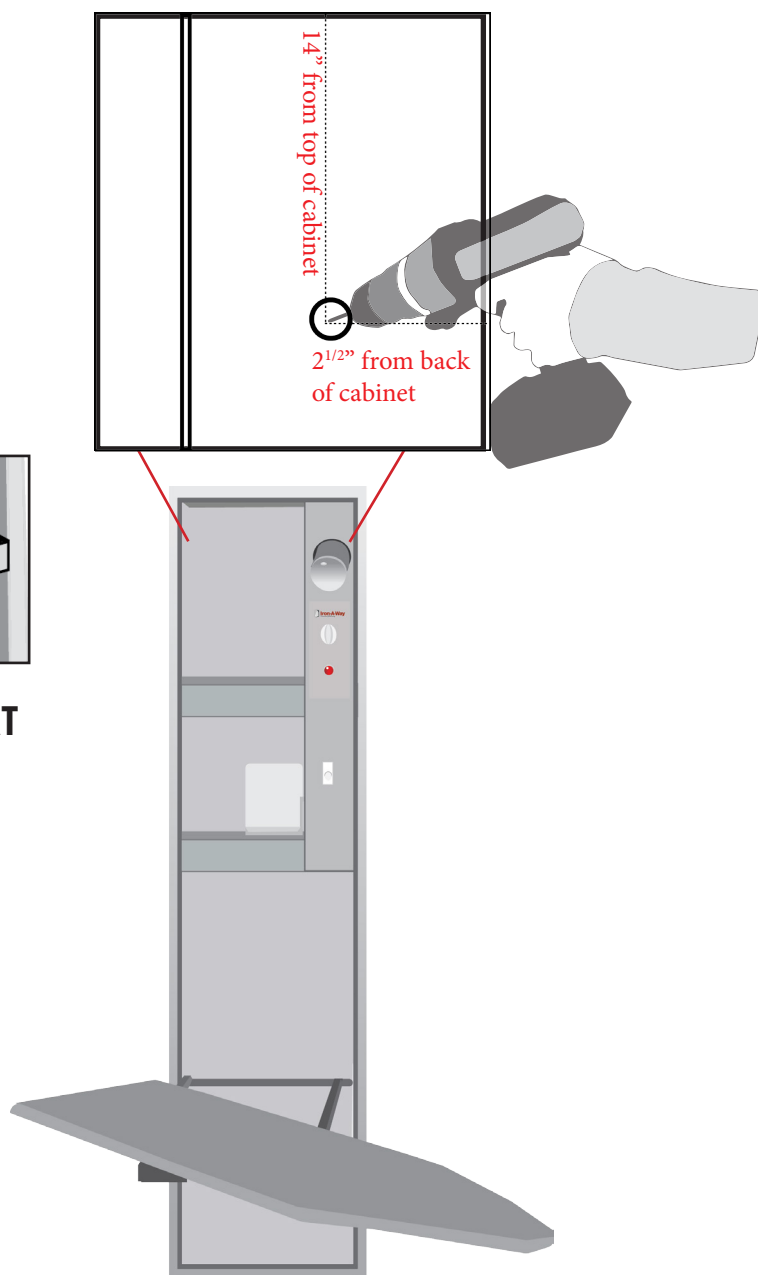

Ensure that power is disconnected at service entrance before proceeding.

4. REMOVE ELECTRICAL KNOCKOUT

Open the front cover of the raceway by removing the screw at the top and bottom of the raceway.

Locate the electrical knockout, as specified on diagram provided.

Install a 3/8" romex connector where the knockout was removed.



5. INSTALL ELECTRICAL WIRING

Verify that there is ample supply wire available to run from the top of the ironing center to the approximate location of electrical pigtails.

Note: A free wire length of 48" is recommended.

Begin to place the ironing center into its location while feeding the supply wire through electrical knockout, and the 3/8" romex connector through the back of the raceway.

6. INSTALL UNIT IN WALL

Begin installation by carefully lifting unit into the wall opening. Make sure the cabinet is plumb and level. If needed, add shims to help unit fit snug in place.

7. ATTACH CABINET TO STUDS

Using the pre-drilled holes in top of cabinet, attach unit to studs with two #10 x 1 1/2" screws for top installation.



Example shown with studs to illustrate mounting.

8. REMOVE BRACKET SCREW

Locate side ironing board brackets that are secured to cabinet with three screws. **Then remove the top screw from each bracket.** This is where the bottom part of your cabinet will be secured to the studs.

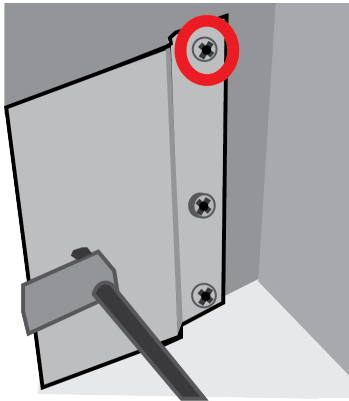

9. PRE-DRILL HOLES IN SIDES

Pre-drill holes into the cabinet using the holes in side brackets where screws were just removed.

Finish installation by inserting the two #14 x 2^{1/2}" screws into the pre-drilled holes to secure bottom part of cabinet.

10. CONNECT WIRES

Connect all power supply wires and ground wires in accordance with all electrical codes. Trim supply wire as necessary.

11. REPLACE RACEWAY COVER

Place the raceway cover into position, ensuring that no wires are pinched. Reinstall the top and bottom screw to secure in place.

Reconnect power supply.

12. INSTALLATION COMPLETE!

Cabinet is now fully installed! If desired, decorative trim or molding may be added to cover any irregularities in the wall.

SURFACE MOUNT INSTALLATION

1. PREPARE CABINET

Screws will be drilled through the upper and lower cross braces (see *illustration on pg.3*) inside the cabinet. Determine location of screws, ensuring that the location of the mounting screw is as close to the center of the cabinet as possible.

2. PRE-DRILL PILOT HOLES

Using a 1/4" drill bit, pre-drill holes in the upper and lower cross braces inside the cabinet as determined in previous step. Ensure that the holes in both braces are drilled to the same measurement.

3. LOCATE & MARK STUD

Using a stud finder, locate stud in wall and mark the wall according to the pre-drilled holes in cabinet. Setting cabinet aside, pre-drill holes using a 1/4" drill bit. **Do not attempt to drill into hard board of cabinet.**

4. PARTIALLY INSERT SCREW

Partially insert a #14 x 4" screw in the upper cross brace.

Ensure that power is disconnected at service entrance before proceeding.

5. REMOVE ELECTRICAL KNOCKOUT

Open the front cover of the raceway by removing the screw at the top and bottom of the raceway.

Locate the electrical knockout, as specified on diagram provided.

Install a 3/8" romex connector where the knockout was removed.

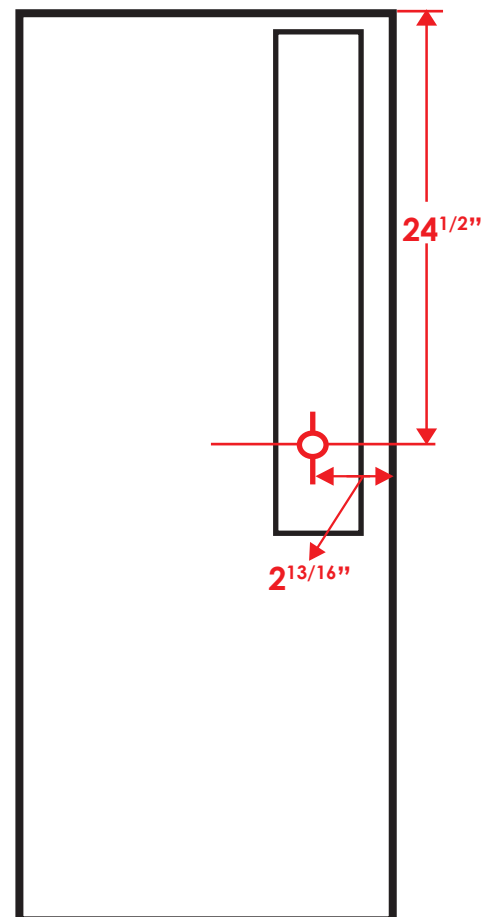

6. INSTALL ELECTRICAL WIRING

Verify that there is ample supply wire available to run from the top of the ironing center to the approximate location of electrical pigtails.

Note: A free wire length of 48" is recommended.

Begin to place the ironing center into its location while feeding the supply wire through electrical knockout, and the 3/8" romex connector through the back of the raceway.

7. INSTALL UNIT

Begin installation by carefully lifting unit into position. Then, attach the cabinet to the wall by fully inserting the screw in the upper cross brace into the wall stud.

Make sure the unit is plumb and level. Shim if necessary. **Fully tighten installation screw.**

8. INSERT SECOND SCREW

Insert the second #14 x 4" screw into the pre-drilled hole in the bottom brace of the cabinet and attach to wall making sure cabinet remains square and level.

9. ADD TRIM

Add decorative trim or molding to make cabinet sides flush with the face frame.

10. REMOVE BRACKET SCREW

Locate side ironing board brackets that are secured to cabinet with three screws. **Then remove the top screw from each bracket.** Replace with a #14 x 3/4" Phillips screw. This will add stability long-term.

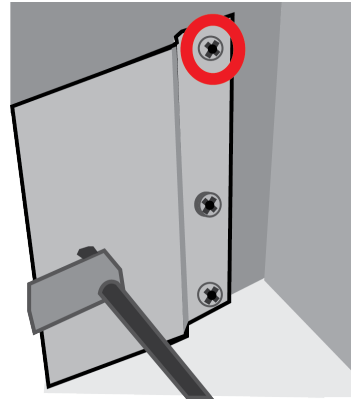

11. CONNECT WIRES

Connect all power supply wires and ground wires in accordance with all electrical codes. Trim supply wire as necessary.

12. REPLACE RACEWAY COVER

Place the raceway cover into position, ensuring that no wires are pinched. Reinstall the top and bottom screw to secure in place.

Reconnect power supply.

13. INSTALLATION COMPLETE

Cabinet is now fully installed!