

# ID Infinity Drain

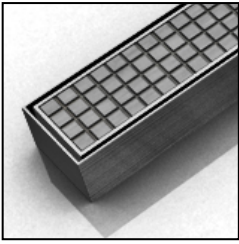

## S-TIFAS 99 Series SITE SIZABLE STAINLESS STEEL

- S-TIFAS 9940 - 40" Complete Kit
- S-TIFAS 9948 - 48" Complete Kit
- S-TIFAS 9960 - 60" Complete Kit
- S-TIFAS 9980 - 80" Complete Kit
- S-TIFAS 9996 - 96" Complete Kit

### Features

- Modify length and outlet location on site
- Indoor or outdoor use
- Stainless steel channel
- 12 gauge, 304L stainless steel perforated grate
- Works with 3" clamp down floor with 4" throat/strainer size *(included)*
- NOT INTENDED for installation across a barrier-free threshold
- Compatible with: PVC Liner, Rubber Liner (Chloraloy®), Hot Mop, Lead Pan, Copper Pan, or Fiberglass
- Flow rate - 21 gpm per outlet
  - Flow rate measured at outlet only. Measurement does not account for water in channel or sheeting on shower floor.
  - Additional outlets can be added and combined into a larger waste line to increase flow rates

### Installation

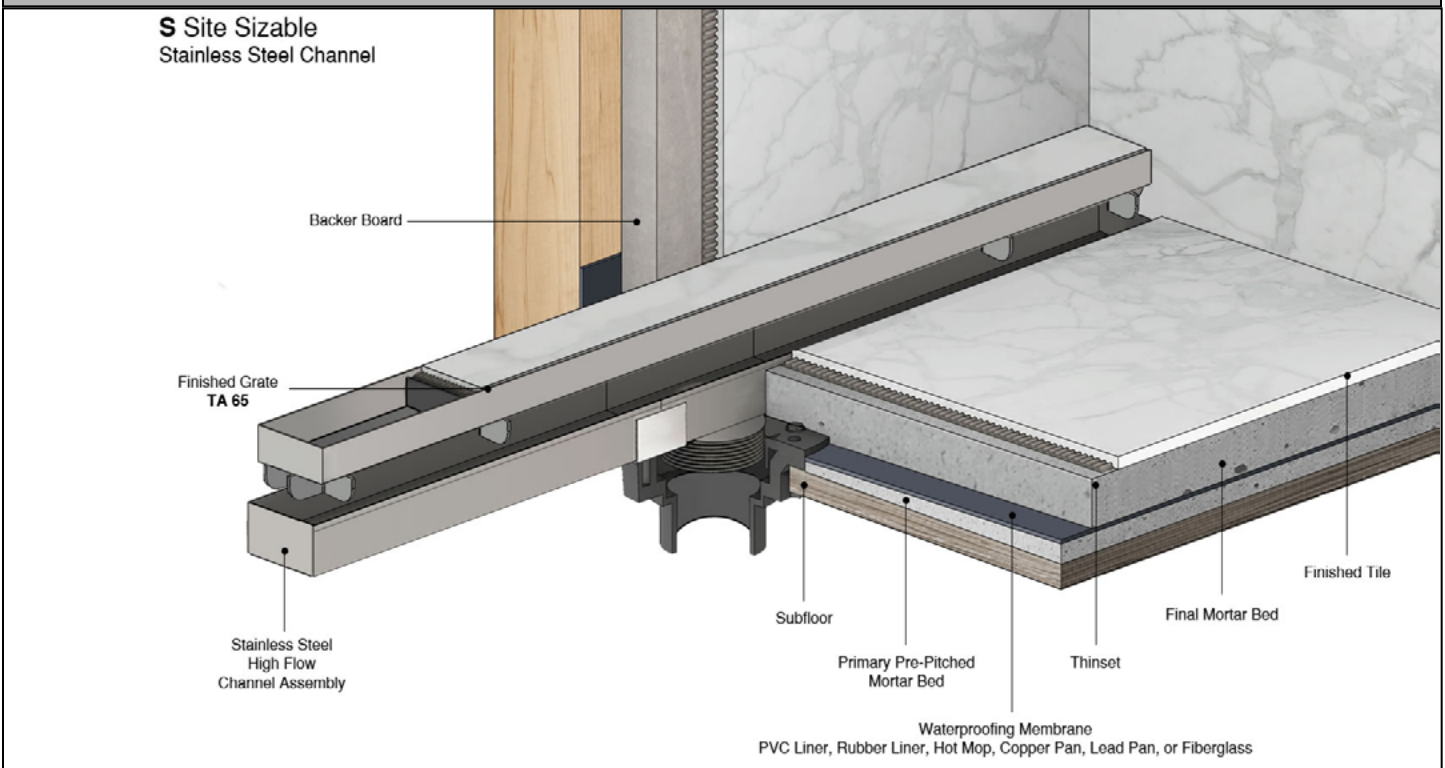

### Care & Maintenance

S-TIFAS 99 stainless steel linear drain top grates are made of 304L stainless steel. This material is non-porous, hygienic, rust-free and extremely durable. Bar Keepers Friend® and Soft Scrub® are commonly available products that can be used to protect and clean your Satin Stainless drain cover. For stains that have been left for an excessive amount of time, stronger cleaning agents such as Compound 302® may be needed. For Polished Stainless and Oil Rubbed Bronze we recommend a mild soap and a soft cloth for cleaning. DO NOT use any abrasive cleaners, scrub pads or allow household cleaning agents, such as bleach, to sit on the drain cover for a long period of time. Stainless steel does not rust. External factors, such as contamination from other highly ferrous metals, built up road salt, sea salt, or chlorine may have caused "surface" rust which can be removed using Barkeepers Friend®, Soft Scrub® with Bleach, or Compound 302®. Always follow the directions on the bottle. Follow proper maintenance procedures to prevent excessive surface rust. In areas of frequent exposure to salt, chlorine, and other chemical compounds, maintenance of the stainless grates should be performed at least 2-3 times per year.

Infinity Drain  
18 Secatoag Avenue  
Port Washington, NY 11050  
Phone: 516.767.6786  
Fax: 516.740.3066  
www.Infinity Drain.com

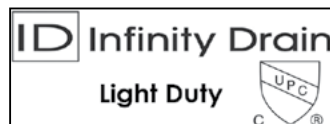

NOTE: Installer must verify all rough-in dimensions prior to installation and consult local and national codes. Conformity and compliance to local and national codes are the responsibility of the installer.

# ID Infinity Drain

S-TIFAS 9940

S-TIFAS 9948

S-TIFAS 9960

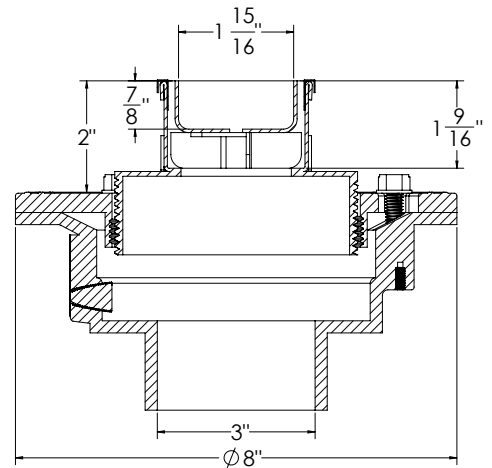
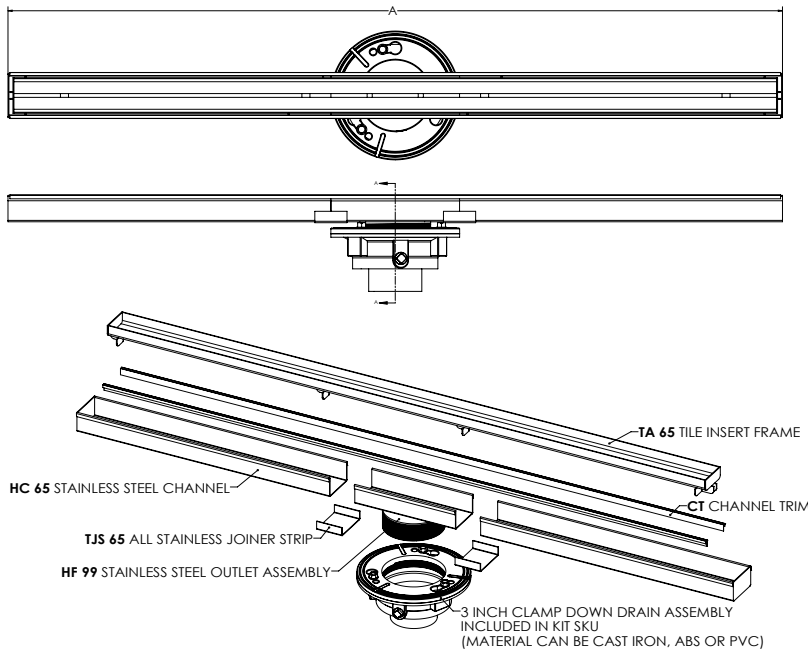

SECTION A-A

Model Number	Complete Kit Contents	A Maximum Overall Length	B Maximum Grate Length	C (Minimum Height Above Waterproofing) * All heights can be adjusted upwards an additional 1-1/4"
<input type="checkbox"/> S-TIFAS 9940	1 - TA 6540 Tile Insert Frame 1 - HC 6532 Stainless Steel Channel 1 - HF 99 8" Outlet Section Stainless Steel 2 - TJS 65 Stainless Steel Joiner Strip 1 - TNAS Threaded Nipple 1 - ZSIKA Sikaflex 1a Sealant 1 - HS 2 Hair Strainer 2 - CT 40 Channel Trim 1 - AKEY Lift Out Key	40"	39 7/8"	With CDI 43: 2" With CDA 43: 2" With CDP 43: 2"
<input type="checkbox"/> S-TIFAS 9948	1 - TA 6548 Tile Insert Frame 1 - HC 6540 Stainless Steel Channel 1 - HF 99 8" Outlet Section Stainless Steel 2 - TJS 65 Stainless Steel Joiner Strip 1 - TNAS Threaded Nipple 1 - ZSIKA Sikaflex 1a Sealant 1 - HS 2 Hair Strainer 2 - CT 48 Channel Trim 1 - AKEY Lift Out Key	48"	47 7/8"	With CDI 43: 2" With CDA 43: 2" With CDP 43: 2"
<input type="checkbox"/> S-TIFAS 9960	1 - TA 6560 Tile Insert Frame 1 - HC 6552 Stainless Steel Channel 1 - HF 99 8" Outlet Section Stainless Steel 2 - TJS 65 Stainless Steel Joiner Strip 1 - TNAS Threaded Nipple 1 - ZSIKA Sikaflex 1a Sealant 1 - HS 2 Hair Strainer 2 - CT 60 Channel Trim 1 - AKEY Lift Out Key	60"	59 7/8"	With CDI 43: 2" With CDA 43: 2" With CDP 43: 2"

**Finishes**

Satin Stainless

Polished Stainless

Infinity Drain  
 145 Dixon Avenue  
 Amityville, NY 11701  
 Phone: 516.767.6786  
 Fax: 516.740.3066  
 www.Infinity Drain.com

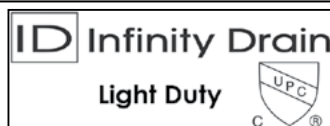

NOTE: Installer must verify all rough-in dimensions prior to installation and consult local and national codes. Conformity and compliance to local and national codes are the responsibility of the installer.

# ID Infinity Drain

S-TIFAS 9980

S-TIFAS 9996

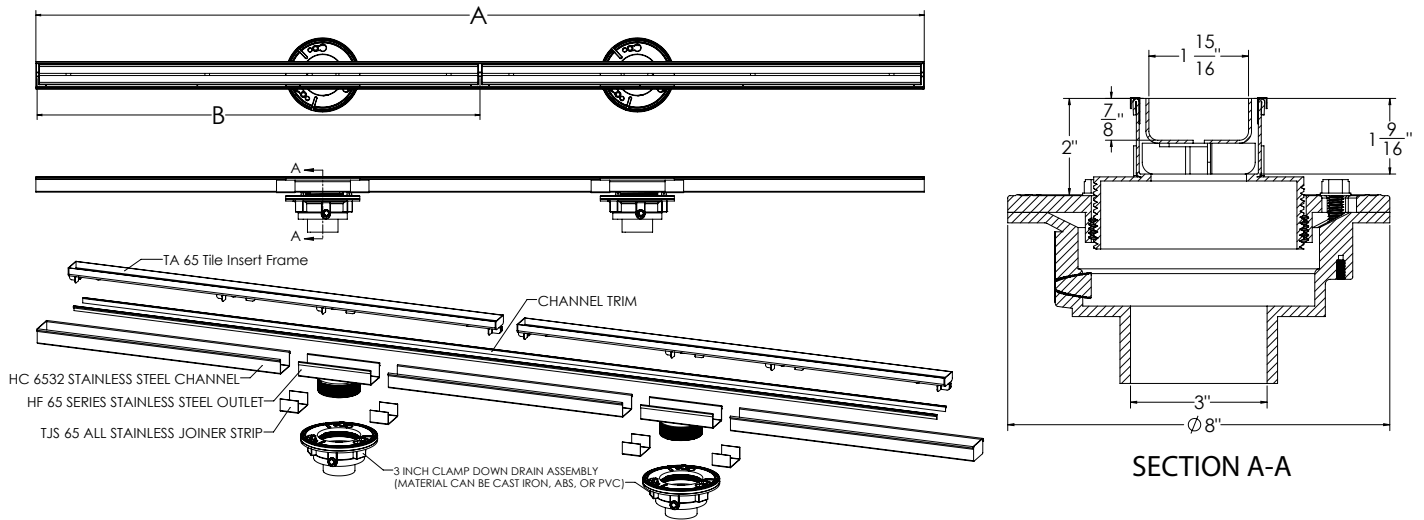

Model Number	Complete Kit Contents	A Maximum Overall Length	B Maximum Grate Length	C (Minimum Height Above Waterproofing) * All heights can be adjusted upwards an additional 1-1/4"
S-TIFAS 9980	2 - TA 6540 Tile Insert Frame 1 - HC 6572 Stainless Steel Channel 2 - HF 99 8" Outlet Section Stainless Steel 4 - TJS 65 Stainless Steel Joiner Strip 2 - TNAS Threaded Nipple 1- ZSIKA Sikaflex 1a Sealant 2 - HS 2 Hair Strainer 2 - CT 80 Channel Trim 1 - AKEY Lift Out Key	80"	39 7/8" (x 2)	With CDI 43: 2" With CDA 43: 2" With CDP 43: 2"
S-TIFAS 9996	2 - TA 6548 Tile Insert Frame 1 - HC 6588 Stainless Steel Channel 2 - HF 99 8" Outlet Section Stainless Steel 4 - TJS 65 Stainless Steel Joiner Strip 2 - TNAS Threaded Nipple 1- ZSIKA Sikaflex 1a Sealant 2 - HS 2 Hair Strainer 2 - CT 96 Channel Trim 1 - AKEY Lift Out Key	96"	47 7/8" (x 2)	With CDI 43: 2" With CDA 43: 2" With CDP 43: 2"

Optional Components	
UCP 4	Universal 4" Clamping Plate
TNRN-4	4" Cast Iron Extension Nipple
Add Clamp Down Drain	
CDA 42	Clamp Down Drain ABS
CDI 42	Clamp Down Drain Cast Iron
CDP 42	Clamp Down Drain PVC
CDA 43	Clamp Down Drain ABS
CDI 43	Clamp Down Drain Cast Iron
CDP 43	Clamp Down Drain PVC

Available components for longer lengths			
TA 6540	40" Tile Insert Frame	TE 65	2" Stainless Steel End Section
TA 6548	48" Tile Insert Frame	TJS 65	Stainless Steel Joiner Strip
TA 6560	60" Tile Insert Frame	SHA 65	Stainless Steel 90° Angle Joiner
TC 6548	48" Stainless Open Ended Channel	HF 99	8" Stainless Steel Outlet Section
TC 6596	96" Stainless Open Ended Channel	CT 40	40" Channel Trim
HC 6532	32" Stainless Closed Channel	CT 48	48" Channel Trim
HC 6540	40" Stainless Closed Channel	CT 60	60" Channel Trim
HC 6552	52" Stainless Closed Channel	CT 80	80" Channel Trim
HC 6572	72" Stainless Closed Channel	CT 96	96" Channel Trim
HC 6588	88" Stainless Closed Channel		

Infinity Drain  
 145 Dixon Avenue  
 Amityville, NY 11701  
 Phone: 516.767.6786  
 Fax: 516.740.3066  
 www.Infinity Drain.com

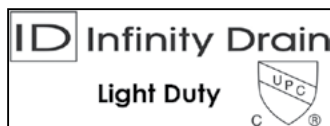

NOTE: Installer must verify all rough-in dimensions prior to installation and consult local and national codes. Conformity and compliance to local and national codes are the responsibility of the installer.