

FXED 65

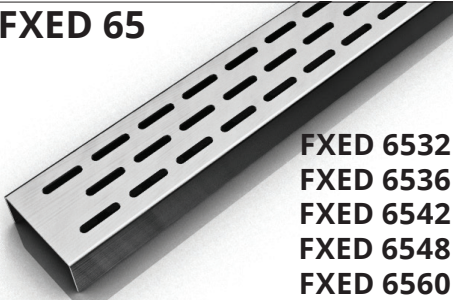

FXED 6532
FXED 6536
FXED 6542
FXED 6548
FXED 6560

FXDG 65

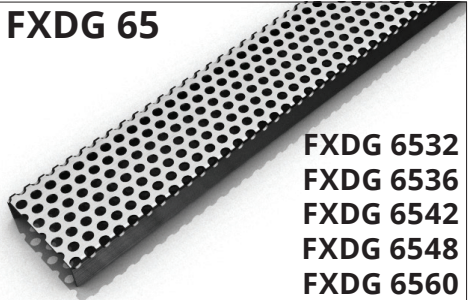

FXDG 6532
FXDG 6536
FXDG 6542
FXDG 6548
FXDG 6560

FXAS 65

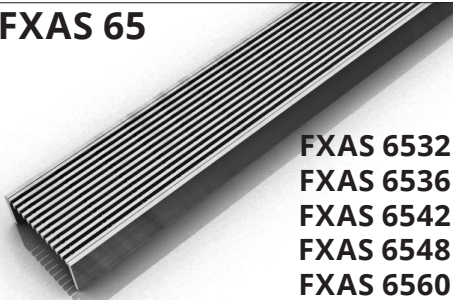

FXAS 6532
FXAS 6536
FXAS 6542
FXAS 6548
FXAS 6560

FXMN 65

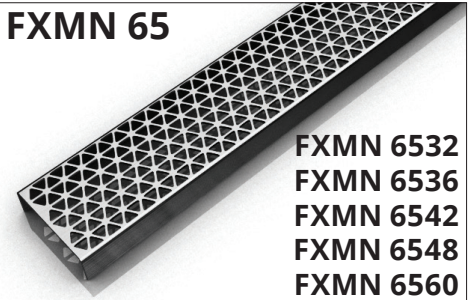

FXMN 6532
FXMN 6536
FXMN 6542
FXMN 6548
FXMN 6560

FXAS125

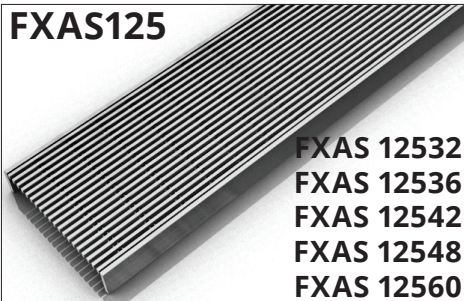

FXAS 12532
FXAS 12536
FXAS 12542
FXAS 12548
FXAS 12560

**FXTIF 65
TD 50**

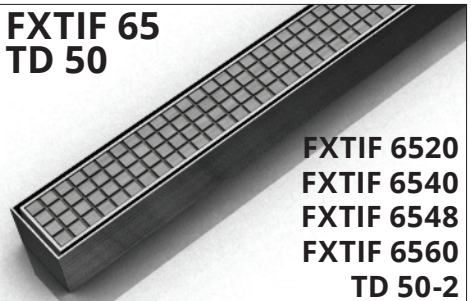

FXTIF 6520
FXTIF 6540
FXTIF 6548
FXTIF 6560
TD 50-2

FXC CUSTOM

The Fixed Length Series intended for use with traditional waterproofing methods:

- Hot Mop ◦ Copper Pan ◦ Rubber Liner (Chloraloy®) ◦ PVC Liner ◦ Lead Pan ◦ Fiberglass

Made in the U.S.A.

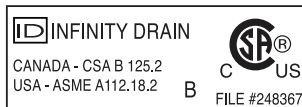
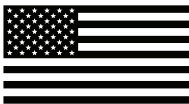

Infinity Drain • 18 Secatoag Avenue, Port Washington, New York 11050
Phone 516.767.6786 • Fax 516.740.3066 • www.InfinityDrain.com

Dimension are subject to Manufacturers tolerance and change without notice. We can assume no responsibility for use of superseded or void data.

Las dimensiones están sujetos a la tolerancia del fabricante y cambio sin previo aviso. No podemos asumir ninguna responsabilidad por el uso de datos a sustituir los nulos.

Series Components:

SS = Stainless Steel

FXED 65 Series	
EA 6532	32" SS Grate
EA 6536	36" SS Grate
EA 6542	42" SS Grate
EA 6548	48" SS Grate
EA 6560	60" SS Grate
XC 6532	32" SS Fixed Channel
XC 6536	36" SS Fixed Channel
XC 6542	42" SS Fixed Channel
XC 6548	48" SS Fixed Channel
XC 6560	60" SS Fixed Channel
HS 2	2" Hair Strainer
TNAS	SS Threaded Nipple

FXDG 65 Series	
DA 6532	32" SS Grate
DA 6536	36" SS Grate
DA 6542	42" SS Grate
DA 6548	48" SS Grate
DA 6560	60" SS Grate
XC 6532	32" SS Fixed Channel
XC 6536	36" SS Fixed Channel
XC 6542	42" SS Fixed Channel
XC 6548	48" SS Fixed Channel
XC 6560	60" SS Fixed Channel
HS 2	2" Hair Strainer
TNAS	SS Threaded Nipple

FXAS 65 Series	
SA 6532	32" SS Grate
SA 6536	36" SS Grate
SA 6542	42" SS Grate
SA 6548	48" SS Grate
SA 6560	60" SS Grate
XC 6532	32" SS Fixed Channel
XC 6536	36" SS Fixed Channel
XC 6542	42" SS Fixed Channel
XC 6548	48" SS Fixed Channel
XC 6560	60" SS Fixed Channel
HS 2	2" Hair Strainer
TNAS	SS Threaded Nipple

FXMN 65 Series	
MA 6532	32" SS Grate
MA 6536	36" SS Grate
MA 6542	42" SS Grate
MA 6548	48" SS Grate
MA 6560	60" SS Grate
XC 6532	32" SS Fixed Channel
XC 6536	36" SS Fixed Channel
XC 6542	42" SS Fixed Channel
XC 6548	48" SS Fixed Channel
XC 6560	60" SS Fixed Channel
HS 2	2" Hair Strainer
TNAS	SS Threaded Nipple

FXAS 125 Series	
SA 12532	32" SS Grate
SA 12536	36" SS Grate
SA 12542	42" SS Grate
SA 12548	48" SS Grate
SA 12560	60" SS Grate
XC 12532	32" SS Fixed Channel
XC 12536	36" SS Fixed Channel
XC 12542	42" SS Fixed Channel
XC 12548	48" SS Fixed Channel
XC 12560	60" SS Fixed Channel
HS 4	4" Hair Strainer
TN4A	SS Threaded Nipple
CDI 43	Cast Iron Drain Body

FXTIF 65 Series/TD 50	
TA 6520	20" SS Grate
TA 6540	40" SS Grate
TA 6548	48" SS Grate
TA 6560	60" SS Grate
IC 6520	20" SS Fixed Channel
IC 6540	40" SS Fixed Channel
IC 6548	48" SS Fixed Channel
IC 6560	60" SS Fixed Channel
HS 2	2" Hair Strainer
TNAS	SS Threaded Nipple
TKEY	Lift Out Key

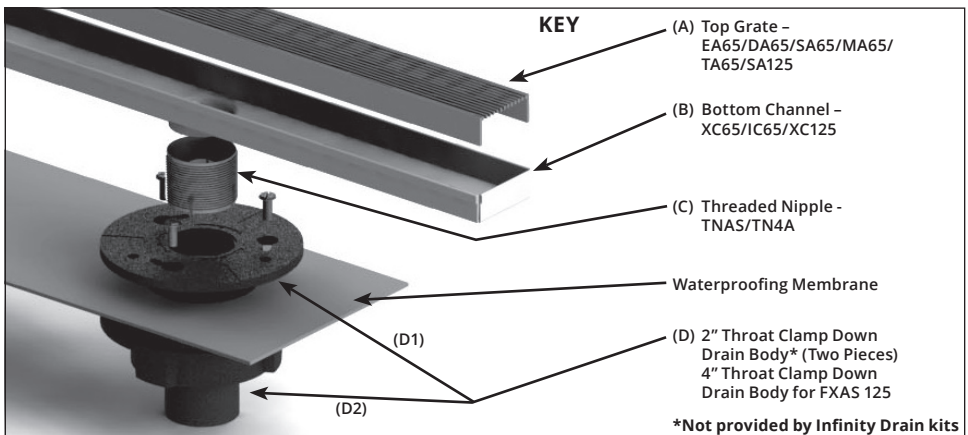

Note: Installer must verify all rough-in dimensions prior to installation and consult local and national codes. Conformity and compliance to local and national codes are the responsibility of the installer.

Tenga en cuenta: Instalador debe comprobar todas las dimensiones en las partes previas a la instalación y consultar localmente y nacionalmente los códigos. La conformidad y el cumplimiento de códigos local y nacional es responsabilidad del instalador.

FXED65/FXDG65/FXMN65/FXAS65/FXTIF65 kits: **DO NOT** include the mechanically fastening clamp down drain due to the variance of material by local code. This is a residential drain that is available through *Infinity Drain* or your local plumbing supply from various manufacturers (i.e. Oatey®, Sioux Chief™, JSC™, PROFLO™, Matco-Norca™).

TD50 kits are provided with a choice of a Cast Iron, ABS or PVC mechanically fastening clamp down drain body. (CDI 22/CDP 22/CDA 22).

FXAS125 kits are provided with a (CDI43) Cast Iron mechanically fastening clamp down drain body. This item can be substituted for an ABS or PVC drain body (CDA 42/CDP 42/CDA 43/CDP 43).

FXED65/FXDG65/FXMN65/FXAS65/FXTIF65 Equipos: **NO INCLUYE** la sujeción mecánica del drenaje por la razón que varía el material de código local. Este drenaje es residencial que está disponible a través de *Infinity Drain* o su local suministro de plomería de diversos fabricantes. (i.e. Oatey®, Sioux Chief™, JSC™, PROFLO™, Matco-Norca™).

TD50 equipos son proveído con una elección de drenaje en hierro fundido, ABS en plástico, o PVC. (CDI 22/CDP22/CDA 22).

FXAS125 equipos are provided with a (CDI43) Cast Iron mechanically fastening clamp down drain body. This item can be substituted for an ABS or PVC drain body (CDA 42/CDP 42/CDA 43/CDP 43).

Available Clamp Down Drains: For FXAS 125 ONLY:

CDI 22 Clamp Down Drain Cast Iron	CDA 42 Clamp Down Drain, ABS, 4" Throat, 2' No Hub Outlet
CDP 22 Clamp Down Drain PVC	CDP 42 Clamp Down Drain, PVC, 4" Throat, 2" No Hub Outlet
CDA 22 Clamp Down Drain ABS	CDI 42 Clamp Down Drain, Cast Iron, 4" Throat, 2" No Hub Outlet
	CDA 43 Clamp Down Drain, ABS, 4" Throat, 3" No Hub Outlet
	CDP 43 Clamp Down Drain, PVC, 4" Throat, 3" No Hub Outlet

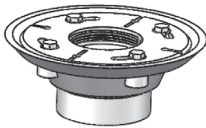

2" clamp down drain **not included** in kit

Optional Components: (Not Included)

UCP 2 Universal 2" Clamping Plate
UCP 4 Universal 4" Clamping Plate
TNRN Stainless Steel Threaded Nipple (Extends drain height 4")
ERB Eccentric Reducer Bushing 4"x2"

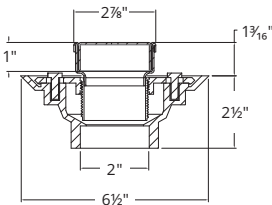
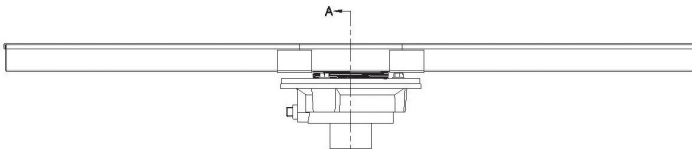

Section A-A
FXED 65, FXDG 65,
FXMN 65, FXAS 65

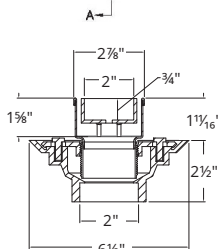

Section A-A
FXTIF 65/TD 50

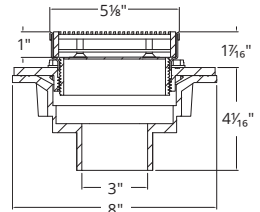

Section A-A
FXAS 125

Installation

1. Determine the location of the drain outlet location. Typically linear drains span a dimension from wall to wall, against a wall or at a shower entrance.

OPTIONAL PROCEDURE:

When drain install is required to be flush against the finished wall, build out wall with backer board over round clamp down drain body (D) to compensate for the drain radius.

OPTIONAL PROCEDURE

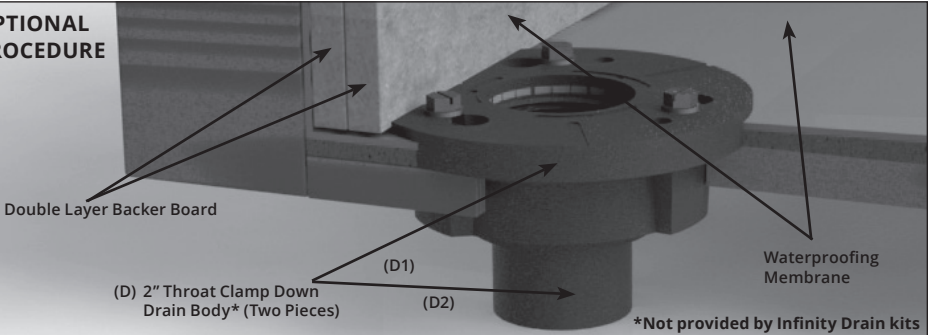

2. If clamp down drain body (D) is not installed. Attach drain body (D2) to existing waste line and allow drain to recess into subfloor. **Ensure** that drain body (D2) is **level**. Unscrew and remove top clamp down plate (D1) from drain body .

3. Spread a primary mortar bed across the intended shower area. Pitch this bed in four directions towards the drain body (D2).

4. When mortar layer is dry, perform necessary waterproofing (PVC Liner, Rubber Liner, Lead Pan, Copper Pan, Hot Mop, Fiberglass) as per local code. Ensure waterproofing layer reaches the edge of the hole in the drain body (D2).

Instalación

1. Determine la ubicación del emplazamiento del drenaje. Típicamente el drenaje lineal atraviesa una dimensión de pared a pared, contra la pared, o en una entrada de un baño.

PROCEDIMIENTO OPCIONAL:

Cuando el drenaje sea instalado, se requiere que esté completamente a la pared, construir la pared con múltiples de placas de cemento sobre el redondo drenaje (D) para compensar el radial del drenaje.

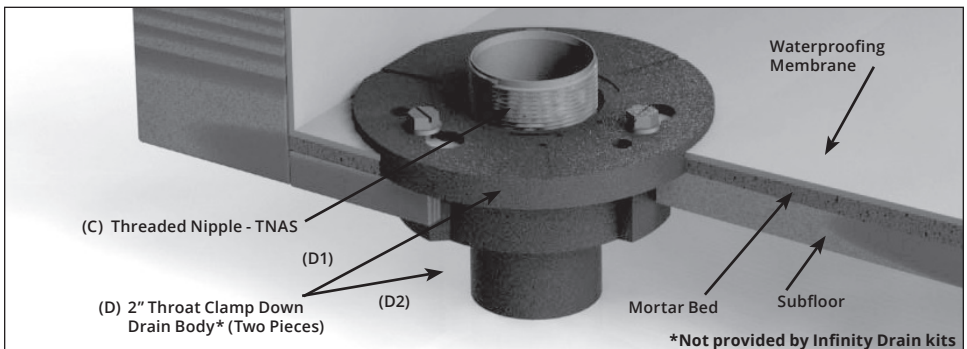

5. Reattach the top clamp down plate (D1) to the clamp down drain body (D2) over the waterproofing layer using bolts. Screw threaded nipple (C) into top clamp down plate (D1). Adjust to the desired height. Turn clockwise to lower, counter-clockwise to raise.

5. Vuelva a colocar la placa de sujeción de arriba del drenaje (D2) sobre las capas de impermeabilización utilizando tornillo. Enrosca el niple roscado (C) adentro de la placa del drenaje (D1). Adaplarla a la altura que desea. Gire hacia la derecha para bajar, hacia la izquierda para subir.

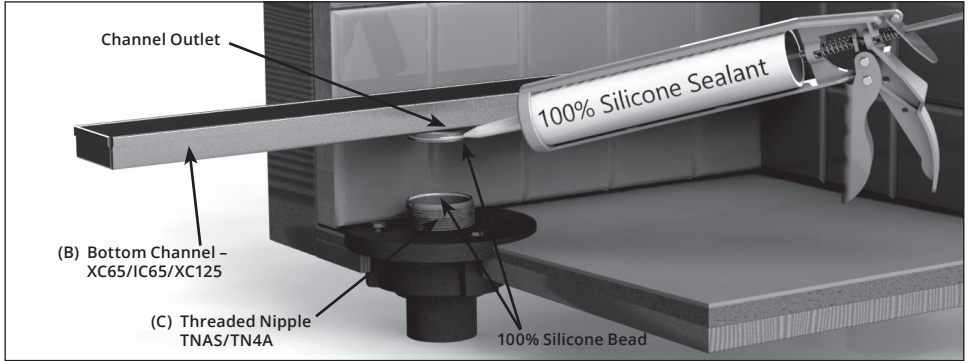

6. Clean lip of the outlet hole using denatured alcohol. Apply a bead of silicone caulk around the outside of the outlet of the stainless steel channel (B). Press channel outlet into the threaded nipple (C) to create a water tight seal. Be sure to support the length of the channel after setting.

6. Limpie el reborde de la salida del agujero en la parte baja del canal de PVC usando alcohol desnaturalizado. Aplicar un cordón de sellador de silicona alrededor del exterior del canal de acero inoxidable (B). Presione el agujero del canal hacia el interior del niple roscado (C) para crear un sello hermético. Asegure que la longitud este compatible al canal después de establecer.

7. Create a mortar bed the length of the channel on the waterproofing membrane and backfill the underside of the stainless steel channel and level. Use necessary amount of mortar to adequately support the channel.

7. Crear un base de mortero de la longitud del canal en la membrana de impermeabilización y rellene la parte de inferior del canal de acero inoxidable y nivélelo. Utilice la cantidad necesaria de mortero para soportar adecuadamente el canal.

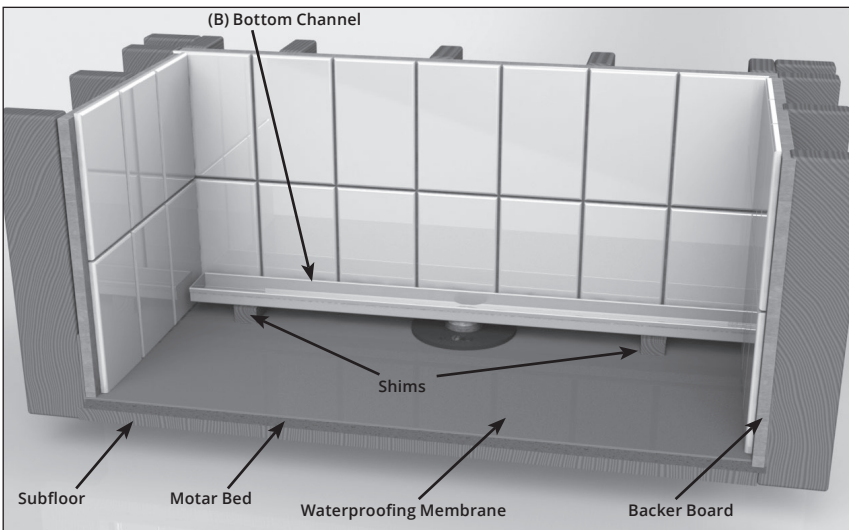

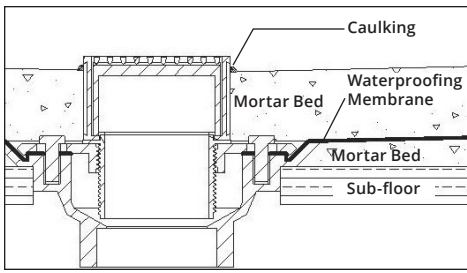

Before finishing material

Antes que el material esté terminado

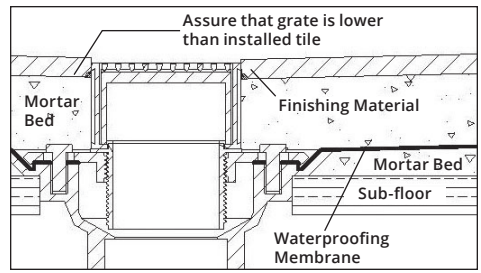

After finishing material

Después que el material esté terminado

8. Using desired floor material, mark the thickness of the material along the channel so that it will finish 1/16" above the channel. Lay final mortar bed across the wet area. Pitch this bed in one plane toward the linear drain. Ensure space for thinset and finishing material to finish 1/16" above the channel. After dry, apply a bead of silicone caulk around the channel. Lay thinset and finishing material, and have material finish to the edge of the combined stainless steel channel. **DO NOT** allow finishing material to finish on top of the stainless steel channel edge.

9. **FXTIF 65/TD 50 INSTALL:** Spread a layer of mortar into the Tile Insert Frame (TA65), allowing for thinset and finishing material to finish 1/16" above the metal frame. Allow to dry, spread thinset and lay material.

8. Utilizando el material de piso deseado, marque el espesor del material a lo largo del canal para que termine 1/16" arriba del canal. Sentar la última capa de mortero a través de la zona mojada. Lanzar esta capa en un plano hacia el drenaje lineal. Asegura que el espacio para el thinset y el material terminen 1/16" arriba del canal. Una vez este seco, aplique un cordón de silicona alrededor del canal. Colocar el thinset y material terminado, y tener el material terminado al borde del canal de acero inoxidable. **NO DEJE o PERMITA** que el material terminado termine en la parte superior del canal de acero inoxidable.

9. **FXTIF 65/TD 50 INSTALACION:** Extender una capa de mortero en la inserción en la parte (TA65), permitiendo el thinset y el material terminado a 1/16" arriba de la estructura de metal. Permitir que se seque, difundir el thinset y tender el material.

