

# ID Infinity Drain

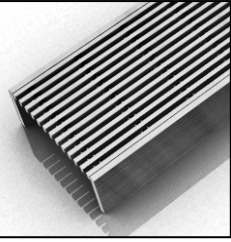

## S-AS 65 Series

### SITE SIZABLE STAINLESS STEEL

- S-AS 6536 - 36" Complete Kit
- S-AS 6548 - 48" Complete Kit
- S-AS 6560 - 60" Complete Kit
- S-AS 6572 - 72" Complete Kit
- S-AS 6596 - 96" Complete Kit

### Features

- Modify length and outlet location on site
- Indoor or outdoor use
- Stainless steel channel
- 316L stainless steel Wedge Wire grate
- Works with 2" clamp down floor with 2" throat/strainer size *(not included)*
- Compatible with: PVC Liner, Rubber Liner (Chloraloy®), Hot Mop, Lead Pan, Copper Pan, or Fiberglass
- Flow rate - 9 gpm per outlet
  - Flow rate measured at outlet only. Measurement does not account for water in channel or sheeting on shower floor.
  - Additional outlets can be added and combined into a larger waste line to increase flowrates

### Installation

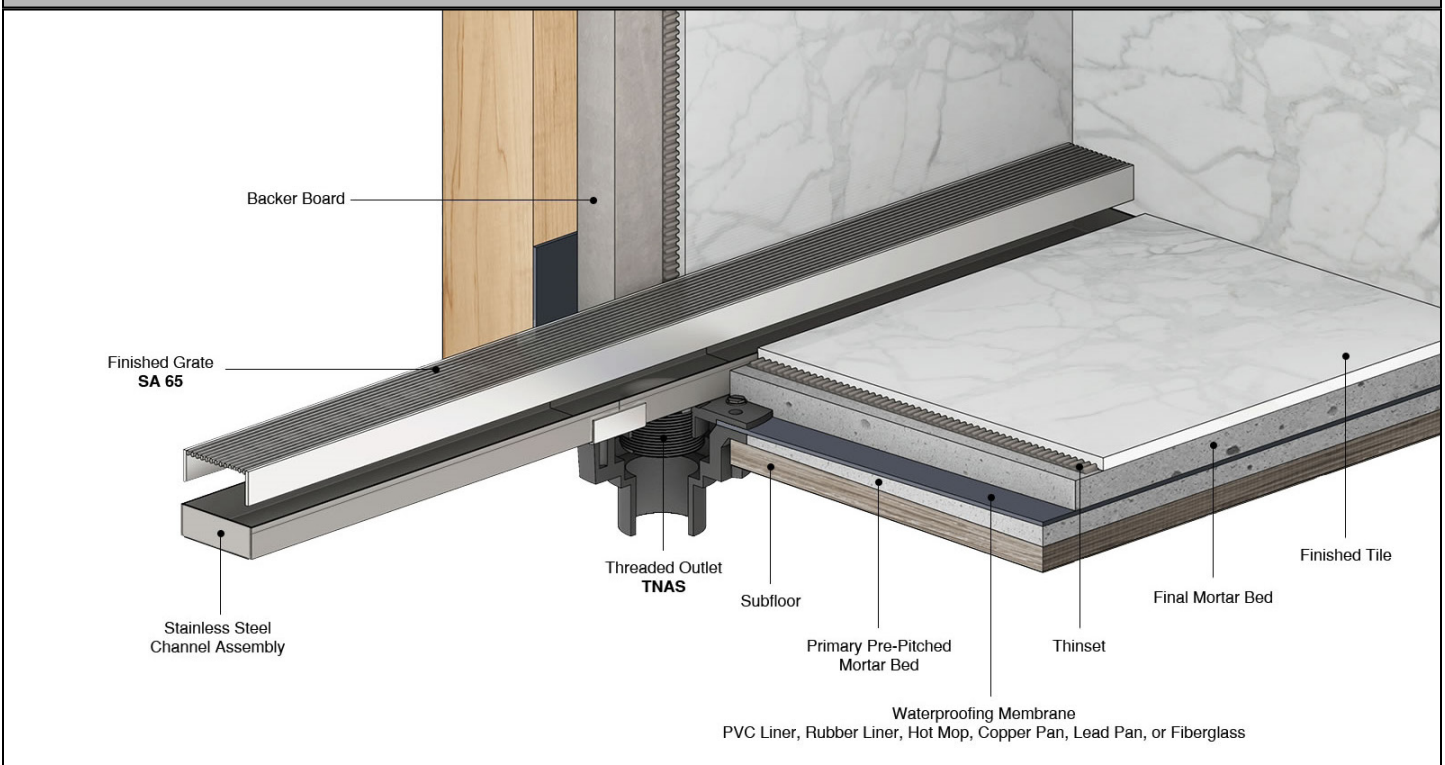

### Care & Maintenance

S-AS 65 stainless steel linear drain top grates are made of 316L stainless steel. This material is non-porous, hygienic, rust-free and extremely durable. Bar Keepers Friend® and Soft Scrub® are commonly available products that can be used to protect and clean your Satin Stainless drain cover. For stains that have been left for excessive time, stronger cleaning agents such as Compound 302® may be needed. For Polished Stainless and Oil Rubbed Bronze we recommend a mild soap and a soft cloth for cleaning. DO NOT use any abrasive cleaners, scrub pads or all household cleaning agents, such as bleach, sit on your drain cover for a long period of time. Stainless steel does not rust. External factors, such as contamination from other highly ferrous metals, built up road salt, sea salt, or chlorine may have caused "surface" rust which can be removed using Barkeepers Friend®, Soft Scrub® with Bleach, or Compound 302®. Always follow the directions on the bottle. Follow proper maintenance procedures to prevent excessive surface rust. In areas of frequent exposure to salt, chlorine, and other chemical compounds, maintenance of the stainless grates should be preformed at least 2-3 times per year.

**Infinity Drain**  
 18 Secatoag Avenue  
 Port Washington, NY 11050  
 Phone: 516.767.6786  
 Fax: 516.740.3066  
 www.Infinity Drain.com

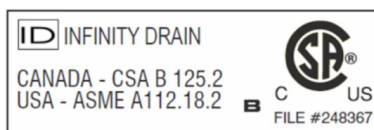

NOTE: Installer must verify all rough-in dimensions prior to installation and consult local and national codes. Conformity and compliance to local and national codes are the responsibility of the installer.

# ID Infinity Drain

S-AS 6536

S-AS 6548

S-AS 6560

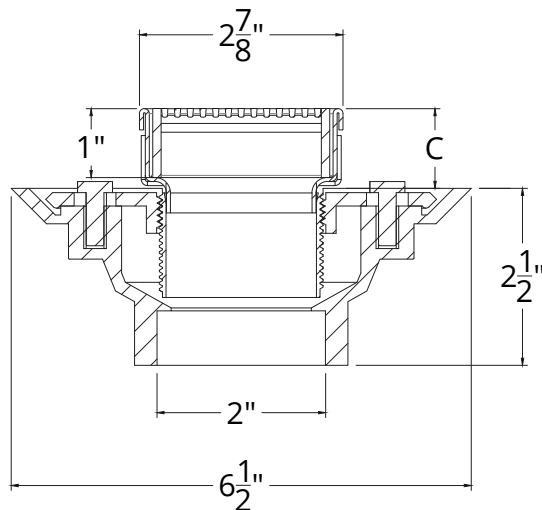
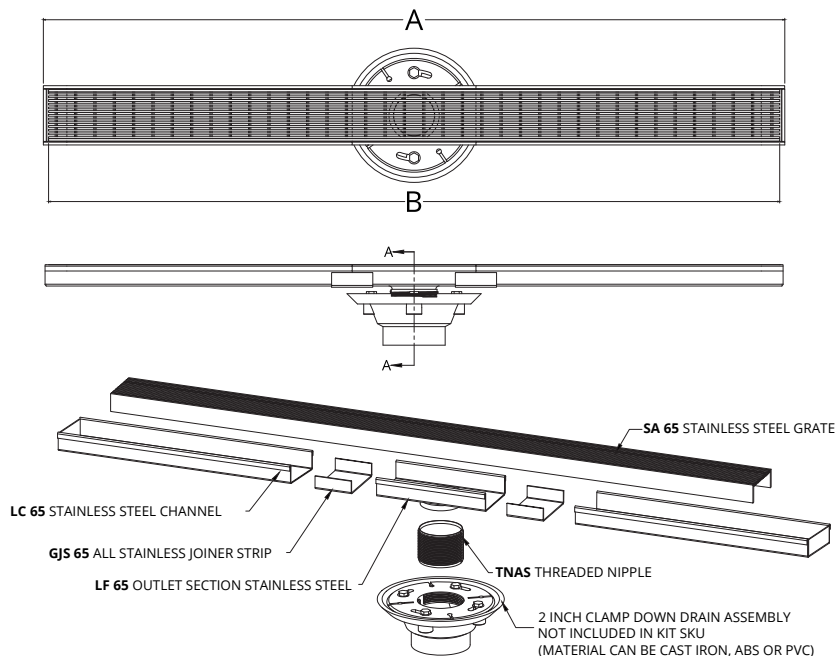

Model Number	Complete Kit Contents	A Maximum Overall Length	B Maximum Grate Length	C (Minimum Height Above Waterproofing) * All heights can be adjusted upwards an additional 1-1/4"
<input type="checkbox"/> S-AS 6536	1 - SA 6536 Stainless Steel Grate 1 - LC 6528 Stainless Steel Channel 1 - LF 65 8" Outlet Section Stainless Steel 2 - GJS 65 Stainless Steel Joiner Strip 1 - TNAS Threaded Nipple 1 - ZSIKA Sikaflex 1a Sealant 1 - HS 2 Hair Strainer 2 - CT 36 Channel Trim 1 - AKEY Lift Out Key	36"	35 7/8"	With CDI 22: 1-1/2" With CDA 22: 1-3/16" With CDP 22: 1-3/16"
<input type="checkbox"/> S-AS 6548	1 - SA 6548 Stainless Steel Grate 1 - LC 6540 Stainless Steel Channel 1 - LF 65 8" Outlet Section Stainless Steel 2 - GJS 65 Stainless Steel Joiner Strip 1 - TNAS Threaded Nipple 1 - ZSIKA Sikaflex 1a Sealant 1 - HS 2 Hair Strainer 2 - CT 48 Channel Trim 1 - AKEY Lift Out Key	48"	47 7/8"	With CDI 22: 1-1/2" With CDA 22: 1-3/16" With CDP 22: 1-3/16"
<input type="checkbox"/> S-AS 6560	1 - SA 6560 Stainless Steel Grate 1 - LC 6552 Stainless Steel Channel 1 - LF 65 8" Outlet Section Stainless Steel 2 - GJS 65 Stainless Steel Joiner Strip 1 - TNAS Threaded Nipple 1 - ZSIKA Sikaflex 1a Sealant 1 - HS 2 Hair Strainer 2 - CT 60 Channel Trim 1 - AKEY Lift Out Key	60"	59 7/8"	With CDI 22: 1-1/2" With CDA 22: 1-3/16" With CDP 22: 1-3/16"

## Finishes

Satin Stainless

Polished Stainless

**Infinity Drain**  
 18 Secatoag Avenue  
 Port Washington, NY 11050  
 Phone: 516.767.6786  
 Fax: 516.740.3066  
 www.Infinity Drain.com

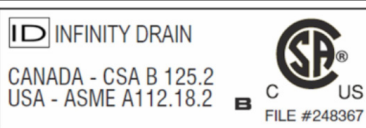

NOTE: Installer must verify all rough-in dimensions prior to installation and consult local and national codes. Conformity and compliance to local and national codes are the responsibility of the installer.

# ID Infinity Drain

S-AS 6572

S-AS 6596

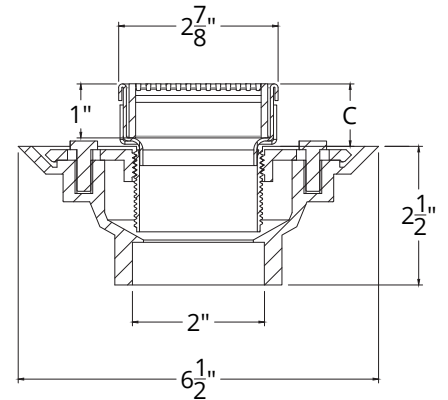
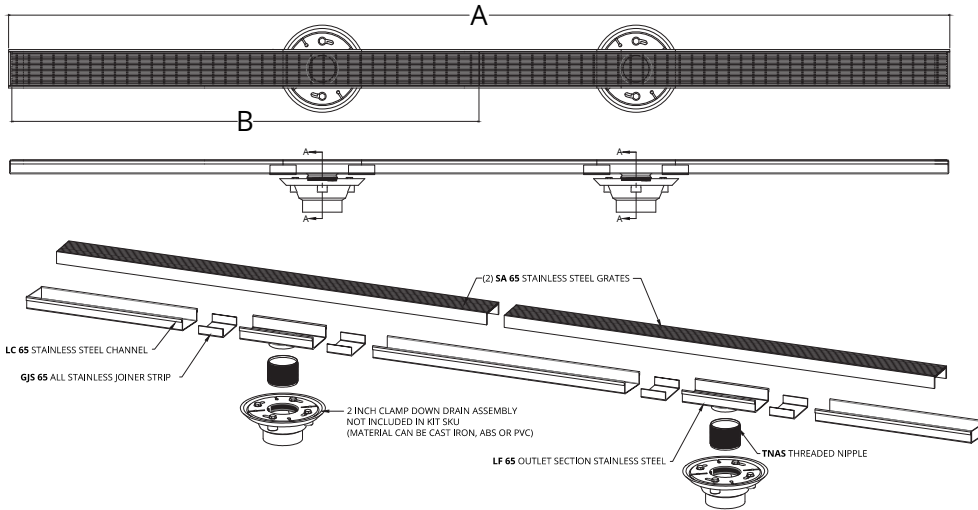

**SECTION A-A**

Model Number	Complete Kit Contents	A Maximum Overall Length	B Maximum Grate Length	C (Minimum Height Above Waterproofing) * All heights can be adjusted upwards an additional 1-1/4"
S-AS 6572	2 - SA 6536 Stainless Steel Grate 1 - LC 6564 Stainless Steel Channel 2 - LF 65 8" Outlet Section Stainless Steel 4 - GJS 65 Stainless Steel Joiner Strip 2 - TNAS Threaded Nipple 1 - ZSIKA Sikaflex 1a Sealant 2 - HS 2 Hair Strainer 2 - CT 72 Channel Trim 1 - AKEY Lift Out Key	72"	35 7/8" (x 2)	With CDI 22: 1-1/2" With CDA 22: 1-3/16" With CDP 22: 1-3/16"
S-AS 6596	2 - SA 6548 Stainless Steel Grate 1 - LC 6588 Stainless Steel Channel 2 - LF 65 8" Outlet Section Stainless Steel 4 - GJS 65 Stainless Steel Joiner Strip 2 - TNAS Threaded Nipple 1 - ZSIKA Sikaflex 1a Sealant 2 - HS 2 Hair Strainer 2 - CT 96 Channel Trim 1 - AKEY Lift Out Key	96"	47 7/8" (x 2)	With CDI 22: 1-1/2" With CDA 22: 1-3/16" With CDP 22: 1-3/16"

**Optional Components**

TNAS-2	2" Long Stainless Steel Resure Nipple
TNAS-3	3" Long Stainless Steel Resure Nipple
TNAS-4	4" Long Stainless Steel Resure Nipple
TNRN-P	PVC Threaded Extension Nipple
UCP 2	Universal 2" Clamping Plate
UCP 42	Universal Reducing Plate (Adapts 4" or 3" existing throat size to 2")

**Add Clamp Down Drain**

CDA 22	Clamp Down Drain ABS
CDI 22	Clamp Down Drain Cast Iron
CDP 22	Clamp Down Drain PVC

**Available components for longer lengths**

SA 6536	36" Wedge Wire Grate	SE 65	2" Stainless Steel End Section
SA 6548	48" Wedge Wire Grate	GJS 65	Stainless Steel Joiner Strip
SA 6560	60" Wedge Wire Grate	SLA 65	Stainless Steel 90° Angle Joiner
SC 6548	48" Stainless Open Ended Channel	HS 2	2" Hair Strainer
SC 6596	96" Stainless Open Ended Channel	LF 65	8" Stainless Steel Outlet Section
LC 6528	28" Stainless Closed Channel	TNAS	Stainless Steel Threaded Nipple
LC 6540	40" Stainless Closed Channel	CT 36	36" Channel Trim
LC 6552	52" Stainless Closed Channel	CT 48	48" Channel Trim
LC 6564	64" Stainless Closed Channel	CT 60	60" Channel Trim
LC 6588	88" Stainless Closed Channel	CT 72	72" Channel Trim
		CT 96	96" Channel Trim

**Infinity Drain**  
 18 Secatoag Avenue  
 Port Washington, NY 11050  
 Phone: 516.767.6786  
 Fax: 516.740.3066  
 www.Infinity Drain.com

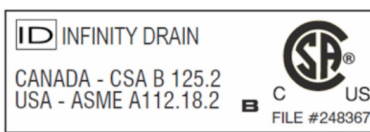

NOTE: Installer must verify all rough-in dimensions prior to installation and consult local and national codes. Conformity and compliance to local and national codes are the responsibility of the installer.