

# RACHAEL 6636

DESIGNER COLLECTION

# H | S

## PVC SYSTEMS INCLUDE:

- 6 or 8 Fully directional adjustable PVC jets
- Anti-vortex safety suction
- Color matched system trim
- HydroOzone ozone sanitation system
- Rigid PVC piping
- Self draining pump and system
- Soft Touch electronic on/off control with 30-minute integral times
- 2.25 HP single speed pump
- Cable waste and overflow
- Requires 20 Amp Dedicated GFCI



Gentle slopes on both ends and a side drain combine to promote timeless elegance in the Rachael. With two larger size models available, the Rachael is an elegant design that always pleases. Visit <http://www.hydrosystem.com> for more details on our options and accessories.



## OPTIONS

- Grab Bars
- Chromatherapy-LED Lighting System
- Chromatherapy-LED Mini Spotlights
- Microban Antibacterial Protection
- Extra high density fiberglass
- Custom jet and pump locations
- Armrests available
- Flange molded
- Skirt
- Plated Metallic finish
- Additional directional Jets
- Swirling, Rotating, or Jumbo Jets
- Micro Therapy Jet
- Integral Waste and Overflow
- 1.5 HP Variable Speed Pump (digital temperature display optional)
- Electronic low water protection
- In-line heater
- Mood Light
- Back Masseur
- Neck Masseur Pillow
- Hydro Fragrance
- Hydro Fusion
- Hydro Coat
- Hydro Express quick ship

**HYDRO SYSTEMS**  
Family Owned And Operated Since 1978

29132 Avenue Paine, Valencia, CA, 91355  
661.775.0686 | [hydrosystem.com](http://hydrosystem.com)

\* Indicates options that are shown (listed in order from top to bottom/ left to right)

# RACHAEL 6636

# H|S

DESIGNER COLLECTION

**As SHOWN:**

Whirlpool option with standard jets

**FEATURES SHOWN:**

- Jets
- Anti-vortex suction
- Overflow location
- 

**ALSO AVAILABLE:**

- Soaking tub only
- Whirlpool
- Thermal Air
- Combo



**SIZE:**

66.36.20

**WATER CAPACITY:**

80 Gallons

**WEIGHT:**

XXX Pounds

**MODEL 6636 DIMENSIONS:**

- (L)ength- 66"
- (W)idth- 36"
- (H)eight Finish- 20"

**ACRYLIC TUB**

- Acrylic models finished in 1/8" thick layer of deep lustrous acrylic
- Extra thick reinforced fiberglass
- Pre-wired pump on pump platform (standard pump location only)
- Integral E-Z level platform facilitates installation
- Non-skid bottom

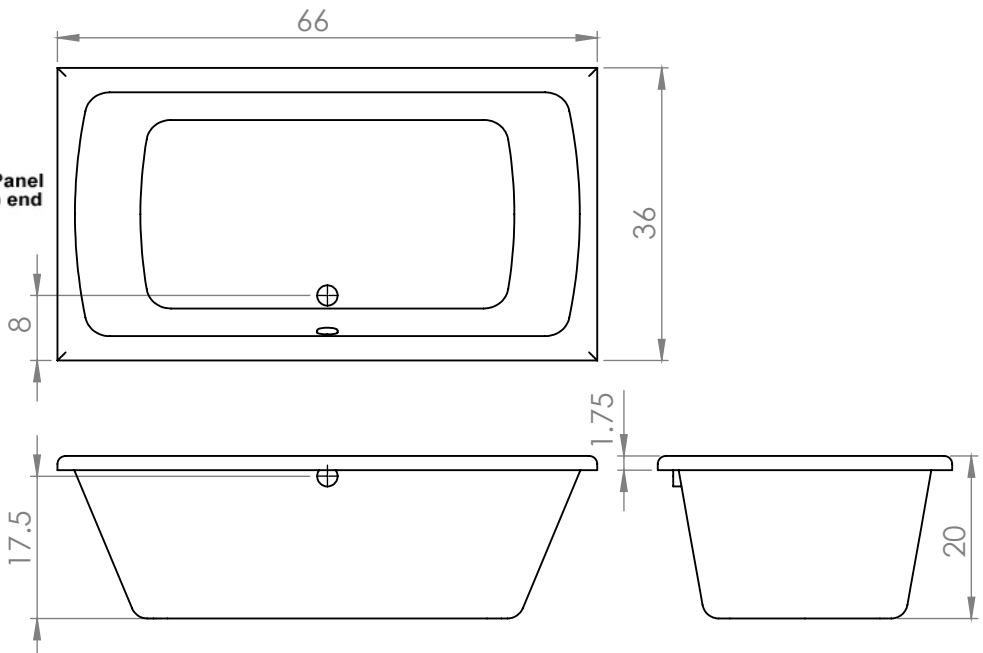
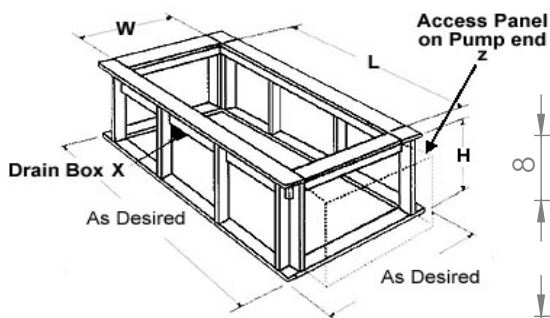

**CODES AND COMPLIANCES**

Massachusetts code File no: P1-0614-491



**HYDRO SYSTEMS**  
Family Owned And Operated Since 1978

29132 Avenue Paine. Valencia, CA, 91355  
661.775.0686 | hydrosystem.com

All specifications and options subject to change without notice please contact a Hydro Systems representative for more information. Certain options or altering the pump/blower location may cause the pump/blower to extend beyond the tub decking. For cutout dimensions wait for unit to arrive. All specifications subject to change without notice.