

# SLATE 7236

STON COLLECTION

# H | S

## AVAILABLE SIZES

- 72.36.24

## WEIGHT

- 398 Pounds

## BACK SLOPE

- 28°

## MATERIAL

- Hydroluxe SS

## STANDARD COLORS

- Almond, White, Biscuit

## PREMIUM COLORS

- Black, Gray, Carbon, Olive, Espresso, Sky Blue, Blue, Royal Blue, Violet, Pink, Yellow, Lime Green, Red

## FINISH

- Matte, Polished, Two-Tone

## WARRANTY

- 10 years



## OPTIONS (more information available on our website)

- Air System
  - Blower and Control Panel must be remotely located
  - Electrical Requirements 1 15 AMP dedicated GFCI - 110 Volt
- Hydro Coat
- Padded Headrest Pillow
- Tower

## INSTALLATION VIDEO AVAILABLE ON WEBSITE:

[WWW.HYDROSYSTEM.COM/TECHNICAL-INFORMATION/VIDEOS/](http://WWW.HYDROSYSTEM.COM/TECHNICAL-INFORMATION/VIDEOS/)

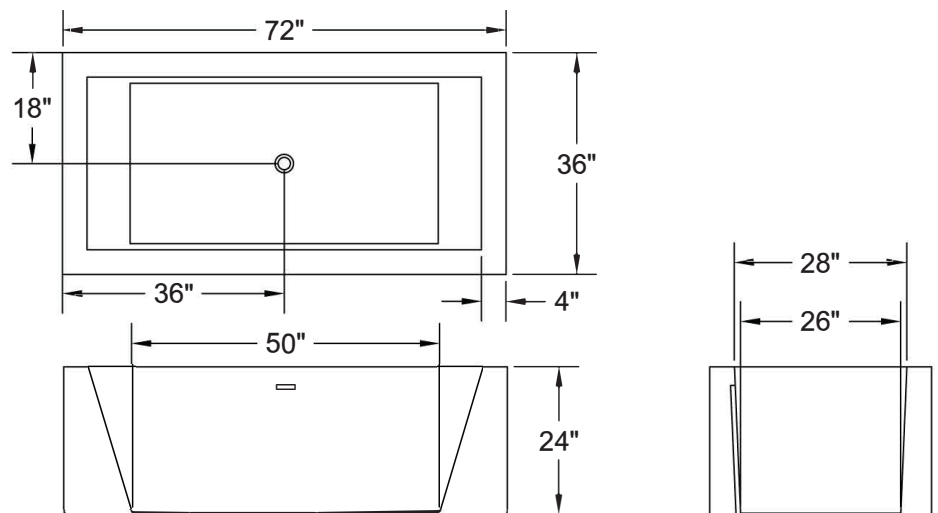

## CODES AND COMPLIANCES

Massachusetts code File no: P1-0614-491



**HYDRO SYSTEMS**  
Family Owned And Operated Since 1978

29132 Avenue Paine, Valencia, CA, 91355  
661.775.0686 | [hydrosystem.com](http://hydrosystem.com)

All specifications and options subject to change without notice please contact a hydro systems representative for more information.