

# SUMMERLIN

METRO COLLECTION



## AVAILABLE SIZES

- 57.31.21.5

## WATER CAPACITY

- 75 Gallons

## WEIGHT

- 300 Pounds

## BACK SLOPE

- 17°

## MATERIAL

- Hydroluxe Solid Surface

## STANDARD COLORS

- White, Biscuit, Bone

## PREMIUM COLORS

- Red, Black, Graphite

## FINISH

- Matte, Polished, Two-Tone

## WARRANTY

- 10 years



## OPTIONS

- Air System
  - Blower and Control Panel must be remotely located
  - Electrical Requirements
    - 1 20 AMP dedicated GFI
- Tower
- Internal Overflow (Standard)

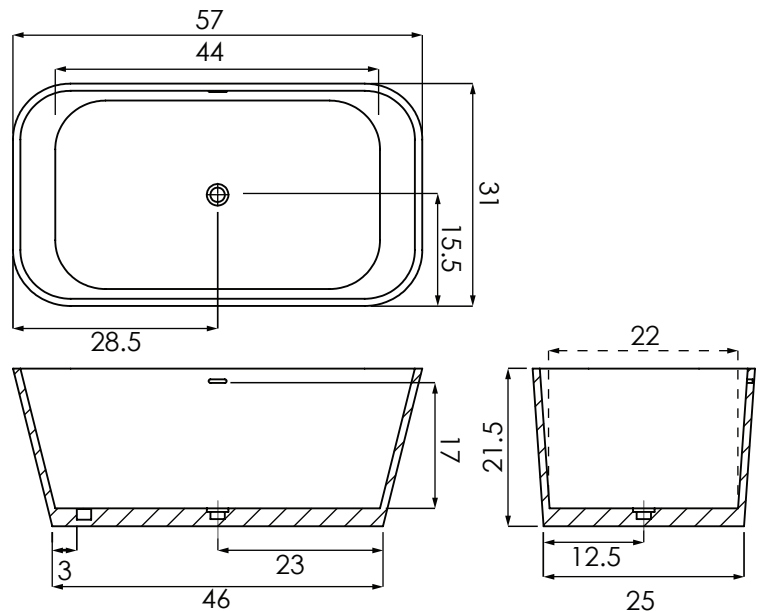

## CODES AND COMPLIANCES

Massachusetts code File no: P1-0614-491



**HYDRO SYSTEMS**  
Family Owned And Operated Since 1978

29132 Avenue Paine, Valencia, CA, 91355  
661.775.0686 | hydrosystem.com

All specifications and options subject to change without notice please contact a hydro systems representative for more information.