

## PREPARING FOR INSTALLATION

Carefully remove all contents from the carton. Shut off the power at the circuit breaker and completely remove the old fixture from the wall, including the old mounting bracket. Remove the new mounting bracket assembly from the bag. Remove cap nuts (G) from mounting screws (D). Place the mounting plate (A) over the junction box so that mounting screws (D) and nuts (C) extend out away from the wall. Adjust the position of mounting screws (D) so that mounting screws (D) can be exposed 5-6 mm after passing through the back plate (F) to properly fit the cap nuts. Mounting screws (D) can be adjusted by loosening nuts (C) and loosening or tightening mounting screws (D). Once the ideal position of mounting screws (D) has been confirmed, tighten nuts (C) on mounting screws (D) on the front of the mounting plate to ensure that mounting screws (D) are secure. Pull the house wires through the center of mounting plate (A). Secure mounting plate (A) to the junction box by tightening the screws (B).

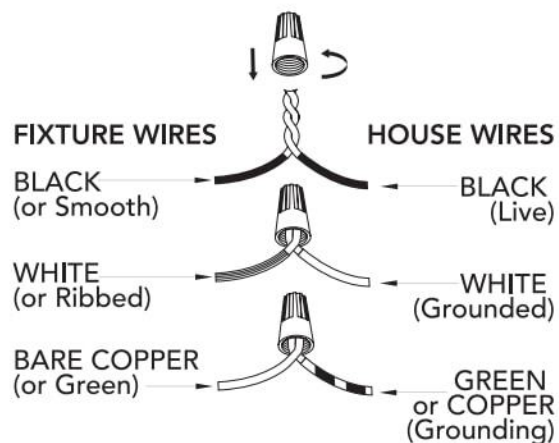

## CONNECTING THE WIRES

Have a helper support the fixture's weight while completing the wiring. Attach the fixture's wires to the power supply wires from the junction box. Connect black to black (live); white to white (neutral); grounding to grounding (green or copper). Twist the ends of the wire pairs together. Then, twist on a wire connector. Make sure all twists are in the same direction. Loop fixture's ground wire around grounding screw (E) and tighten. If there is no ground wire (green or copper) from the junction box, contact a qualified electrician.

## FINISHING THE INSTALLATION

Place the fixture's back plate (F) over the mounting screws (D) so the threads protrude through the holes on the front of the back plate. Tightly screw the cap nuts (G) onto the mounting screws (D) until the back plate (F) of the fixture is snugly against the wall. Lift the glass (I) and align the notches in the glass with the tabs in the lamp cup (H). Attach the glass by lifting and turning clockwise one third of a full turn of the glass until it stops. Install light bulb (not included) in accordance with the fixture's specifications. Do not exceed the recommended wattage. Your installation is now complete. Turn on the power and test the fixture.

## CLEANING TIPS

Treat the fixture gently! Regular cleaning will reduce the need for deep cleaning. For regular cleaning, turn off the light and wipe down the fixture with a clean lint-free cotton or microfiber cloth. Never spray cleaner directly onto the fixture.

# Hunter

## Gatz

For Models:  
Para los Modelos:  
Pour les Modèles:

**19686**  
**19687**  
**45223**

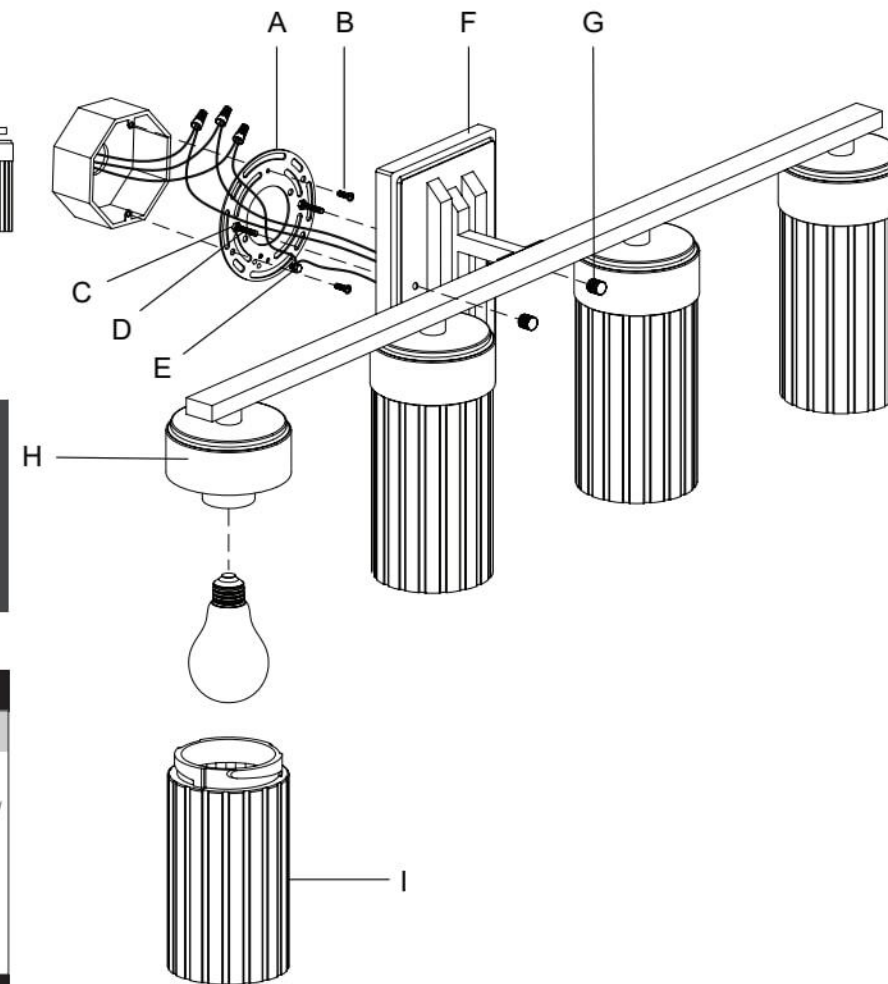
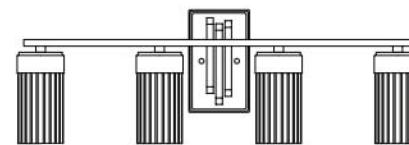

Here are the tools you'll need to complete your installation:  
Estas son las herramientas que usted necesitará para completar su instalación:  
Voici les outils dont vous aurez besoin pour réaliser l'installation:

Hardware Service Kit/Kit De Mantenimiento Del Equipo/Trousse De Maintenance Quincaillerie

4 Light Vanity  
4 Luz Decorativa de Pared  
4 Lumière Vanité

Fixture weight ±2 lbs:  
Peso ±2 lb: 8 lbs (3.6 kg)  
Poids fixe ±2 lbs:

Part #/Pieza #/Pièce #	Model/Modelo/Modèle	Finish/Finish/Fini
KE18101L24	19686	Palm Gold/Dorado Palma/ Palmier Doré
KE18101214	19687	Brushed Nickel/Niquel Pulido/ Nickel Brossé
KE18101895	45223	Matte Black/Negro Mate/ Noir Mat

Glass/Domo De Vidrio/Verre		
Part #/Pieza #/Pièce #	Model/Modelo/Modèle	Type/Tipo/Type
	19686	Clear Fluted Glass/Vidrio
	19687	Acanalado Transparente/Verre
KE29301147	45223	Cannelé Transparent



Ladder  
Escalera  
Échelle

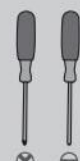

Screwdriver  
Destornillador  
Tournevis



Pliers  
Alicates  
Pince



Wire Strippers  
Pelacables  
Pince à dénuder

## INSTALLATION INSTRUCTIONS

## INSTRUCCIONES DE INSTALACIÓN/ INSTRUCTIONS D'INSTALLATION

### ⚠ WARNING

- To avoid possible electrical shock, before installing your light fixture, disconnect the power by turning off the circuit breakers to the outlet box associated with the wall switch location.
- The lighting fixture must be grounded. If the ground wire for the installation site is not present, immediately **STOP** installation and consult a qualified electrician.
- All wiring must be in accordance with national and local electrical codes ANSI/NFPA 70. If you are unfamiliar with wiring or in doubt, consult a qualified electrician.

### READ AND SAVE THESE INSTRUCTIONS

These instructions are provided for your safety. It is very important that they are read carefully and completely before beginning installation of the lighting fixture.

### ⚠ ADVERTENCIA

- Para evitar una posible descarga eléctrica, antes de instalar su lámpara, desconecte la energía apagando los interruptores automáticos (breakers) que alimentan la caja de salida asociada con la ubicación del interruptor de pared.
- La lámpara se debe conectar a tierra. Si el alambre de conexión a tierra no está presente en el sitio de la instalación, **DETENGA** inmediatamente la instalación y consulte con un electricista calificado.
- Todo el cableado debe realizarse de acuerdo con los códigos eléctricos locales y nacionales ANSI/NFPA 70. Si no está familiarizado con el cableado, o si tiene duda, consulte a un electricista calificado.

### LEA Y GUARDE ESTAS INSTRUCCIONES

Estas instrucciones se proporcionan para su seguridad. Es muy importante leerlas detenidamente y completamente antes de comenzar la instalación de la lámpara.

### ⚠ AVERTISSEMENT

- Pour éviter tout choc électrique, avant d'installer le luminaire, coupez le courant en éteignant les disjoncteurs de la boîte électrique associée à l'interrupteur mural.
- Le luminaire doit être mis à la terre. Si le fil de terre du lieu d'installation n'est pas présent, **ARRÊTER** immédiatement l'installation et consulter un électricien qualifié.
- Tout le câblage doit être conforme aux codes électriques nationaux et locaux en vigueur et à la norme ANSI/NFPA 70. Si vous n'avez pas l'habitude de faire ce câblage ou en cas de doute, adressez-vous à un électricien qualifié.

### LISEZ ET CONSERVEZ CES INSTRUCTIONS

Ces instructions sont fournies pour votre sécurité. Il est très important de les lire attentivement dans leur intégralité avant d'entreprendre l'installation du luminaire.

