

NOVUS SERIES

10mm Radius Undermount Large Single Bowl

Sliding Dual Platforms System

Model : NVS-6500



FEATURES

- Premium grade T-304 stainless steel
- 10" depth • 18 gauge
- MegaShield™ insulation
- Brushed satin, rear-set drain
- 3-1/2" drain opening
- Fits 48" sink base
- Supplied with cutout template, fasteners and instructions
- Includes : Wood Cutting Board, two Drying Trays, Multi-Purpose Roll-Up Mat, Two Bottom grids, Stainless Steel Basket Strainer.
- Lifetime Limited Warranty



TYPE 304
PREMIUM STAINLESS STEEL

MEGA SHIELD
INSULATION

SUPER SILENCER

Lifetime Warranty

OPTIONAL ACCESSORIES

Bottom Grid: BG-4901, BG-4902 Drying Tray: DT-4230, DT-1300
Cutting Board : CB-5300 Roll-Up Mat: RO-1600
Strainer: 190-9180

| OVERALL DIMENSIONS | EACH BOWL | CUTOUT SIZE | PACKAGING* | WEIGHT* |
|--------------------|--------------------|--------------|------------|-------------|
| 45" x 17-13/16" | 43-7/16" x 14-1/4" | See Template | 1/12 pcs. | 45/580 lbs. |

*Standard packaging: Single boxed /Pallet of single boxed.
All dimensions are in inches. Specifications subject to change without notice.

Project/Job name

Architect/Engineer

Contractor

Model

Q'ty

Notes

NVS-6500

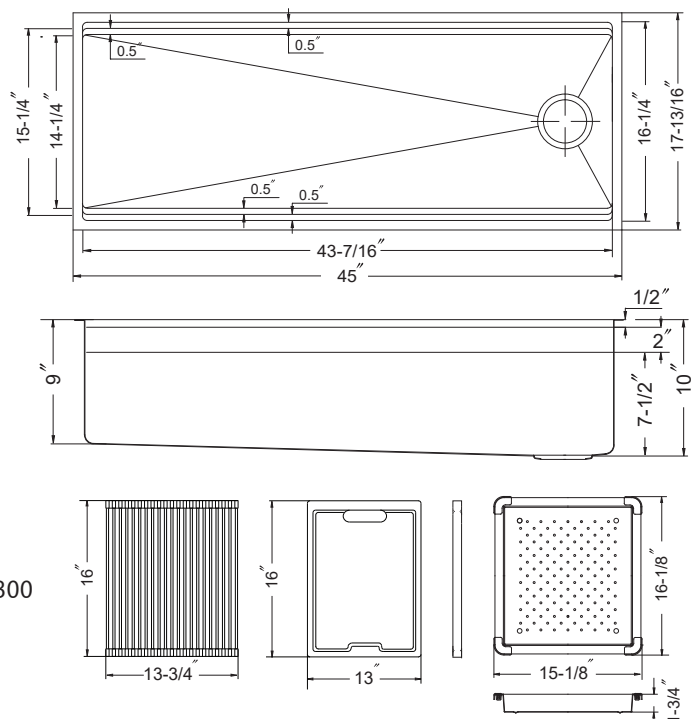

Installation profile

