

House of Troy

Quality Lighting Products

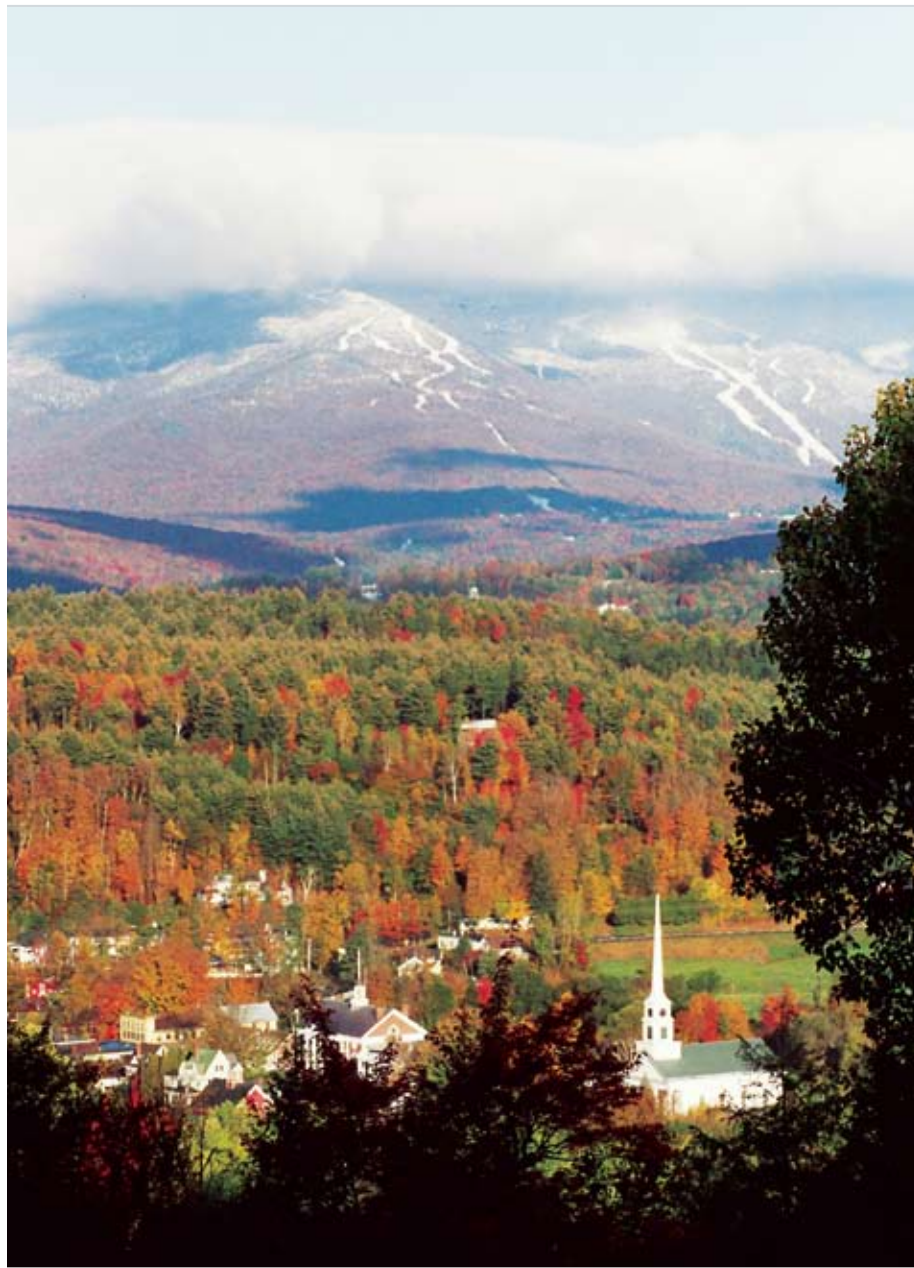

2009

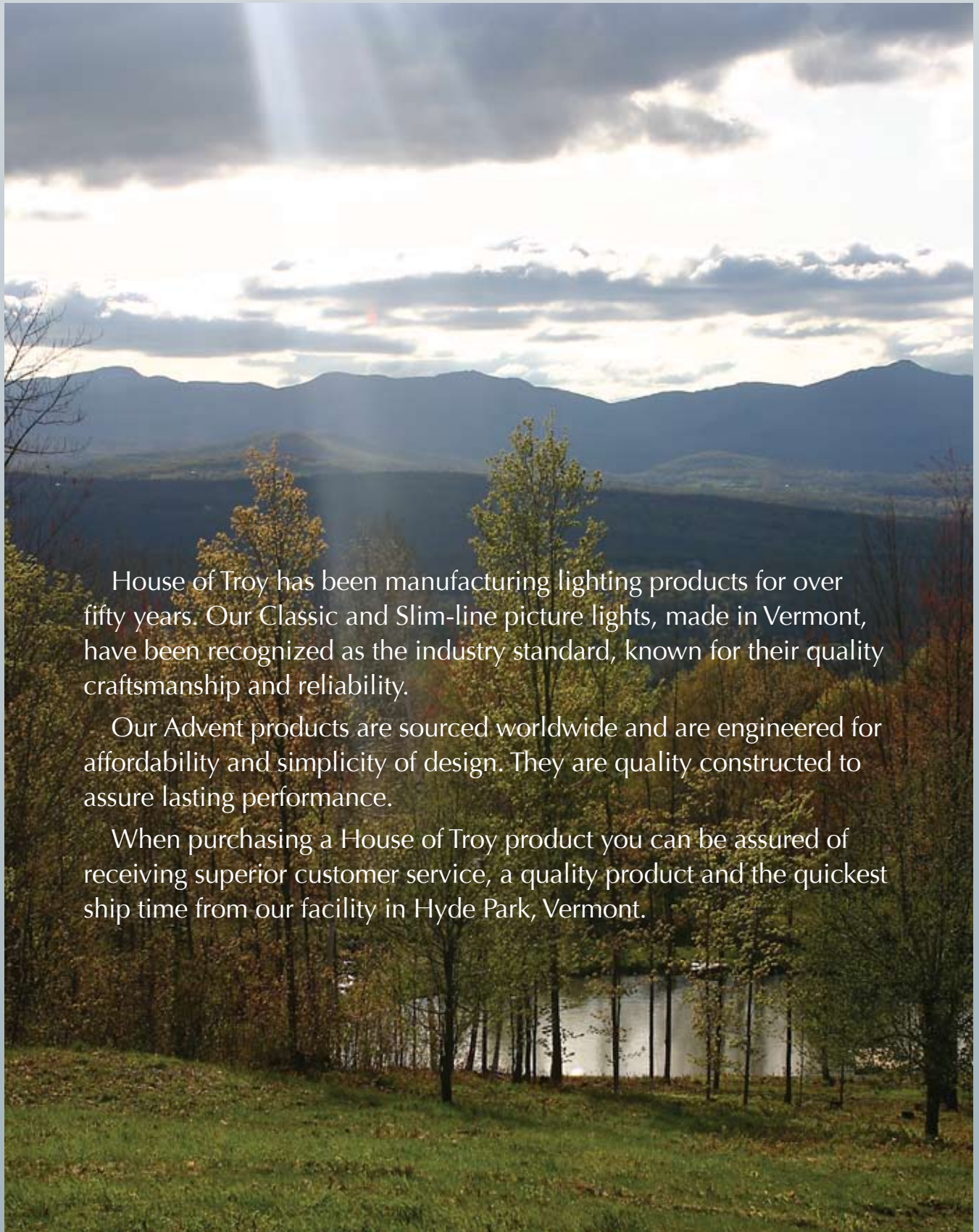

House of Troy has been manufacturing lighting products for over fifty years. Our Classic and Slim-line picture lights, made in Vermont, have been recognized as the industry standard, known for their quality craftsmanship and reliability.

Our Advent products are sourced worldwide and are engineered for affordability and simplicity of design. They are quality constructed to assure lasting performance.

When purchasing a House of Troy product you can be assured of receiving superior customer service, a quality product and the quickest ship time from our facility in Hyde Park, Vermont.

TABLE OF CONTENTS

TABLE LAMPS

Desk/Piano  2-24, 48

Balance Arm  28-29 & 31

Swing Arm Desk  34, 59-60 & 89

Decorative Table  32, 34-35, 38-39, 42, 45, 50-51, 53, 60, 67-68, 76-80, 86-87

PIANO CLAMP LIGHTS

Clamp-on Piano  25-27

FLOOR LAMPS

Torchiere  81

Pharmacy Lamps  40, 46-47, 61-62, 90-91

Balance Floor  30, 69-70

Decorative Floor  35-37, 41, 43, 46, 53, 63, 77, 82, 84-85

WALL SWING LAMPS

Task Wall Swing  44, 49, 54-55 & 88

Decorative Wall Swing  33, 42, 44, 56-57, 65-66, 73-75, 100-105

Double Wall Swing  58

TASK LIGHTING

Portable Spots  121

Cabinet  122-124

PICTURE LIGHTS

Classic  108-113

Direct Wire  107, 111-112, 115-116

Slim-line  107, 114-116

Mantel  110

Halogen  119-120

LED  112, 116-118

Advent  118-120

Battery Operated  117-118

SCONCES

Pin up  52, 64

Decorative Wall  32, 51, 92-99

Library  71-72

Corridor  106

ENERGY EFFICIENT

Desk/Piano  12, 20-25, 48

Balance Arm Table  28-29

Pharmacy Lamps  47

Task Wall Swing  49

Corridor  106

Picture Lights  107, 112, 116-117

CUSTOM OPTIONS 125

FINISHES 127

Q & A 126-127

INDEX 128-129

10" Shades



← P10-101-B

FINISH: Polished Brass & Black Marble
 HEIGHT: Adjusts from 0" to 12"
 BASE: 4½" Square
 BULB: One 40T10 or 60T10
 SWITCH: On shade
 SHADE: 10"
 CORD: 9' Brown



↑ P10-163

FINISH: Polished Brass & Crystal
 HEIGHT: Adjusts from 0" to 13"
 BASE: 5" round
 BULB: One 40T10 or 60T10
 SWITCH: On shade
 SHADE: 10"
 CORD: 9' Brown



← P10-123-81

FINISH: Mahogany Bronze
 HEIGHT: Adjusts from 0" to 13"
 BASE: 5" round
 BULB: One 40T10 or 60T10
 SWITCH: On shade
 SHADE: 10"
 CORD: 9' Brown



→ P10-123

FINISH: Polished Brass
 HEIGHT: Adjusts from 0" to 13"
 BASE: 5" round
 BULB: One 40T10 or 60T10
 SWITCH: On shade
 SHADE: 10"
 CORD: 9' Brown



↑ **P10-107-61**

FINISH: Polished Brass
 HEIGHT: Adjusts from 0" to 10 ½"
 BASE: 5" Octagon
 BULB: One 40T10 or 60T10
 SWITCH: On shade
 SHADE: 10"
 CORD: 9' Brown



→ **P10-152**

FINISH: Polished Brass
 HEIGHT: Adjusts from 0" to 14"
 BASE: 6" Dodecagon
 BULB: One 40T10 or 60T10
 SWITCH: On shade
 SHADE: 10"
 CORD: 9' Brown



← **P10-107-81**

FINISH: Mahogany Bronze
 HEIGHT: Adjusts from 0" to 10 ½"
 BASE: 5" Octagon
 BULB: One 40T10 or 60T10
 SWITCH: On shade
 SHADE: 10"
 CORD: 9' Brown



→ **P10-165-627**

FINISH: Chrome w/ Black
 HEIGHT: Adjusts from 7" to 16.5"
 BASE: 6" round
 BULB: One 40T10 or 60T10
 SWITCH: On shade
 SHADE: 10"
 CORD: 9' Black

10" Shades



← **P10-111-71**

FINISH: Antique Brass
HEIGHT: Adjusts from 0" to 14"
BASE: 5 3/4" Octagon
BULB: One 40T10 or 60T10
SWITCH: On shade
SHADE: 10"
CORD: 9' Brown



← **P10-111**

FINISH: Polished Brass
HEIGHT: Adjusts from 0" to 14"
BASE: 5 3/4" Octagon
BULB: One 40T10 or 60T10
SWITCH: On shade
SHADE: 10"
CORD: 9' Brown



← **P10-111-MB**

FINISH: Mahogany Bronze
HEIGHT: Adjusts from 0" to 14"
BASE: 5 3/4" Octagon
BULB: One 40T10 or 60T10
SWITCH: On shade
SHADE: 10"
CORD: 9' Brown



→ **P10-108**

FINISH: Polished Brass
& Black Marble
HEIGHT: Adjusts from 0" to 13"
BASE: 6" round
BULB: One 40T10 or 60T10
SWITCH: On shade
SHADE: 10"
CORD: 9' Brown

DESK/PIANO LAMPS



← P10-131-71

FINISH: Antique Brass
HEIGHT: Adjusts from 0" to 10 ½"
BASE: 5" round
BULB: One 40T10 or 60T10
SWITCH: On shade
SHADE: 10"
CORD: 9' Brown



→ P10-131-61

FINISH: Polished Brass
HEIGHT: Adjusts from 0" to 10 ½"
BASE: 5" round
BULB: One 40T10 or 60T10
SWITCH: On shade
SHADE: 10"
CORD: 9' Brown



→ P10-130

FINISH: Polished Brass
HEIGHT: Adjusts from
0" to 11"
BASE: 5" round
BULB: One 40T10 or
60T10
SWITCH: On shade
SHADE: 10"
CORD: 9' Brown

14" Shades



← P14-233-617

FINISH: Black with Polished Brass Accents
 HEIGHT: Adjusts from 0" to 16 1/2"
 BASE: 5 1/8" Square
 BULB: Two 40T10 or 60T10
 SWITCH: On base
 SHADE: 14"
 CORD: 9' Black



↑ P14-233-C71

FINISH: Antique Brass & Chestnut Bronze
 HEIGHT: Adjusts from 0" to 16 1/2"
 BASE: 5 1/8" Square
 BULB: Two 40T10 or 60T10
 SWITCH: On base
 SHADE: 14"
 CORD: 9' Brown



← P14-264

FINISH: Polished Brass & Crystal
 HEIGHT: Adjusts from 0" to 13"
 BASE: 5 1/8" Square
 BULB: Two 40T10 or 60T10
 SWITCH: On base
 SHADE: 14"
 CORD: 9' Brown

DESK/PIANO LAMPS



→ **P14-203-81**

FINISH: Mahogany Bronze
 HEIGHT: Adjusts from 0" to 12½"
 BASE: 6" Octagon
 BULB: Two 40T10 or 60T10
 SWITCH: On base
 SHADE: 14"
 CORD: 9' Brown



↑ **P14-203-GT**

FINISH: Granite
 HEIGHT: Adjusts from 0" to 12½"
 BASE: 6" Octagon
 BULB: Two 40T10 or 60T10
 SWITCH: On base
 SHADE: 14"
 CORD: 9' Brown



← **P14-203**

FINISH: Polished Brass
 HEIGHT: Adjusts from 0" to 12½"
 BASE: 6" Octagon
 BULB: Two 40T10 or 60T10
 SWITCH: On base
 SHADE: 14"
 CORD: 9' Brown



→ **P14-203-AB**

FINISH: Antique Brass
 HEIGHT: Adjusts from 0" to 12½"
 BASE: 6" Octagon
 BULB: Two 40T10 or 60T10
 SWITCH: On base
 SHADE: 14"
 CORD: 9' Brown

14" Shades



↑ **P14-204**

FINISH: Polished Brass
HEIGHT: Adjusts from 2" to 16"
BASE: 6¼" round
BULB: Two 40T10 or 60T10
SWITCH: On base
SHADE: 14"
CORD: 9' Brown



→ **P14-204-81**

FINISH: Mahogany Bronze
HEIGHT: Adjusts from 2" to 16"
BASE: 6¼" round
BULB: Two 40T10 or 60T10
SWITCH: On base
SHADE: 14"
CORD: 9' Brown



→ **P14-204-AB**

FINISH: Antique Brass
HEIGHT: Adjusts from 2" to 16"
BASE: 6¼" round
BULB: Two 40T10 or 60T10
SWITCH: On base
SHADE: 14"
CORD: 9' Brown



← **P14-502-52**

FINISH: Satin Nickel with Black Leather
HEIGHT: Adjusts from 0" to 12"
BASE: 5½" Square
BULB: Two 40T10 or 60T10
SWITCH: On base
SHADE: 14"
CORD: 9' Brown

DESK/PIANO LAMPS



← P14-501-71

FINISH: Antique Brass
with Green Leather
HEIGHT: Adjusts from 7" to 19½"
BASE: 5⅛" Square
BULB: Two 40T10 or 60T10
SWITCH: On base
SHADE: 14"
CORD: 9' Brown

↑ P14-501-52

FINISH: Satin Nickel with Black
Leather
HEIGHT: Adjusts from 7" to 19½"
BASE: 5⅛" Square
BULB: Two 40T10 or 60T10
SWITCH: On base
SHADE: 14"
CORD: 9' Brown



← P14-280

FINISH: Mahogany Bronze &
Black & Tan Marble
HEIGHT: Adjusts 0" to 12"
BASE: 5⅛" Square
BULB: Two 40T10 or
60T10
SWITCH: On base
SHADE: 14"
CORD: 9' Brown



→ P14-280-WB

FINISH: Weathered Brass &
Black & Tan Marble
HEIGHT: Adjusts 0" to 12"
BASE: 5⅛" Square
BULB: Two 40T10 or 60T10
SWITCH: On base
SHADE: 14"
CORD: 9' Brown

14" Shades



← **P14-231-61**

FINISH: Polished Brass
 HEIGHT: Adjusts from 0" to 12"
 BASE: 6" round
 BULB: Two 40T10 or 60T10
 SWITCH: In-line 6" from base
 SHADE: 14"
 CORD: 9' Brown



← **P14-231-71**

FINISH: Antique Brass
 HEIGHT: Adjusts from 0" to 12"
 BASE: 6" round
 BULB: Two 40T10 or 60T10
 SWITCH: In-line 6" from base
 SHADE: 14"
 CORD: 9' Brown



→ **P14-212**

FINISH: Polished Brass
 HEIGHT: Adjusts from 0" to 16"
 BASE: 6 3/8" Decagon
 BULB: Two 40T10 or 60T10
 SWITCH: On base
 SHADE: 14"
 CORD: 9' Brown



← **P14-246**

FINISH: Polished Brass & Black Marble
 HEIGHT: Adjusts from 0" to 17"
 BASE: 5 1/8" Square
 BULB: Two 40T10 or 60T10
 SWITCH: In-line 6" from base
 SHADE: 14"
 CORD: 9' Brown

DESK/PIANO LAMPS



← **P14-202-81**

FINISH: Mahogany Bronze
HEIGHT: Adjusts from 0" to 13"
BASE: 5" Square
BULB: Two 40T10 or 60T10
SWITCH: On base
SHADE: 14"
CORD: 9' Brown



→ **P14-202**

FINISH: Polished Brass
HEIGHT: Adjusts from 0" to 13"
BASE: 5" Square
BULB: Two 40T10 or 60T10
SWITCH: On base
SHADE: 14"
CORD: 9' Brown



→ **P14-202-AB**

FINISH: Antique Brass
HEIGHT: Adjusts from 0" to 13"
BASE: 5" Square
BULB: Two 40T10 or 60T10
SWITCH: On base
SHADE: 14"
CORD: 9' Brown

14" Shades

PF14-201
FLUORESCENT OPTION
Uses One F8T5WW Bulb

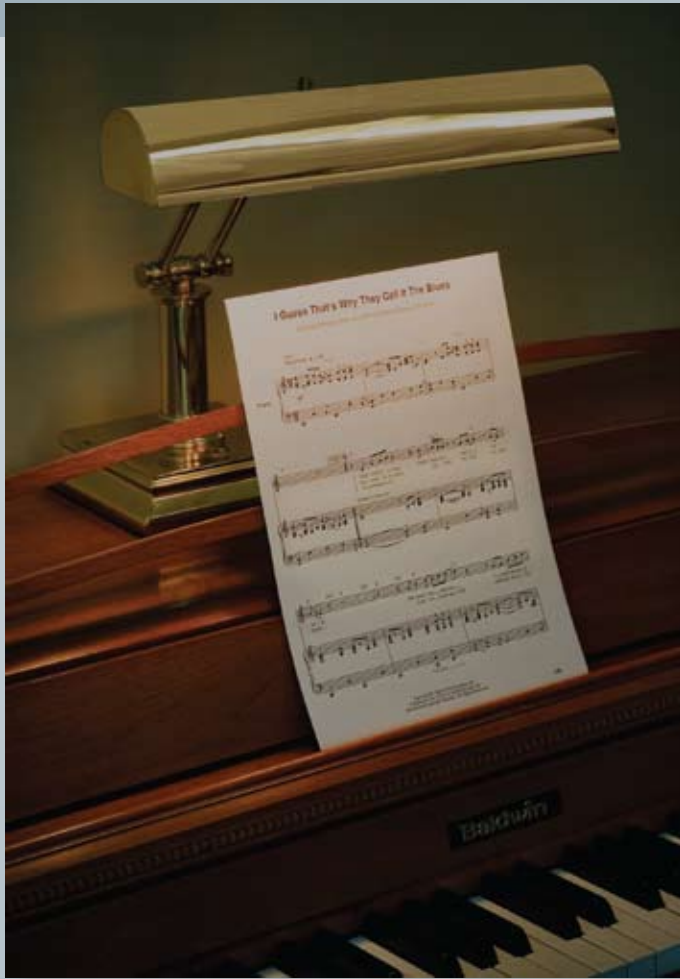

← P14-201

FINISH: Polished Brass
HEIGHT: Adjusts from 0" to 14"
BASE: 6" Square
BULB: Two 40T10 or 60T10
SWITCH: On base
SHADE: 14"
CORD: 9' Brown



← P14-201-GT

FINISH: Granite
HEIGHT: Adjusts from 0" to 14"
BASE: 6" Square
BULB: Two 40T10 or 60T10
SWITCH: On base
SHADE: 14"
CORD: 9' Brown



← P14-201-81

FINISH: Mahogany Bronze
HEIGHT: Adjusts from 0" to 14"
BASE: 6" Square
BULB: Two 40T10 or 60T10
SWITCH: On base
SHADE: 14"
CORD: 9' Brown



→ P14-201-AB

FINISH: Antique Brass
HEIGHT: Adjusts from 0" to 14"
BASE: 6" Square
BULB: Two 40T10 or 60T10
SWITCH: On base
SHADE: 14"
CORD: 9' Brown



← **P14-232-C71**

FINISH: Antique Brass & Chestnut Bronze
 HEIGHT: Adjusts from 0" to 14¾"
 BASE: 5⅞" Square
 BULB: Two 40T10 or 60T10
 SWITCH: On base
 SHADE: 14"
 CORD: 9' Brown



→ **P14-262**

FINISH: Satin Brass with Gold Highlights
 HEIGHT: Adjusts from 0" to 14"
 BASE: 5⅞" Square
 BULB: Two 40T10 or 60T10
 SWITCH: On base
 SHADE: 14"
 CORD: 9' Brown



← **P14-242-71**

FINISH: Antique Brass
 HEIGHT: Adjusts from 8" to 16"
 BASE: 6⅜" round
 BULB: Two 40T10 or 60T10
 SWITCH: In-line 6" from base
 SHADE: 14"
 CORD: 9' Brown

Craft Collection

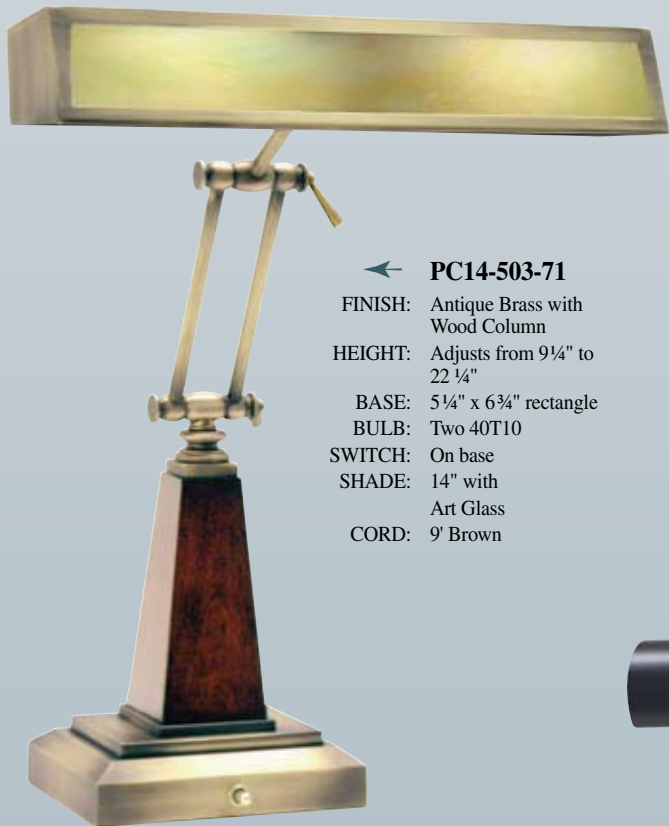

← **PC14-503-71**

FINISH: Antique Brass with Wood Column
 HEIGHT: Adjusts from 9¼" to 22 ¼"
 BASE: 5¼" x 6¾" rectangle
 BULB: Two 40T10
 SWITCH: On base
 SHADE: 14" with Art Glass
 CORD: 9' Brown



→ **PC14-503-52**

FINISH: Satin Nickel with Wood Column
 HEIGHT: Adjusts from 9¼" to 22 ¼"
 BASE: 5¼" x 6¾" rectangle
 BULB: Two 40T10
 SWITCH: On base
 SHADE: 14" with Art Glass
 CORD: 9' Brown



← **P16-101-627**

FINISH: Chrome and Black
 HEIGHT: Adjusts from 0" to 12"
 BASE: 5" Square
 BULBS: Two 40T10 or 60T10
 SWITCH: On base
 SHADE: 16"
 CORD: 9' Black



↑ **P16-100-627**

FINISH: Chrome and Black
 HEIGHT: Adjusts from 7" to 16½"
 BASE: 6" round
 BULBS: Two 40T10 or 60T10
 SWITCH: In line 6" from base
 SHADE: 16"
 CORD: 9' Black

Advent Collection

DESK/PIANO LAMPS



← **AP14-41-71**

FINISH: Antique Brass
HEIGHT: Adjusts from 0" to 12"
BASE: 6" round
BULB: Two 40T10
SWITCH: In-line 6" from base
SHADE: 14"
CORD: 9' Brown



↑ **AP14-41-61**

FINISH: Polished Brass
HEIGHT: Adjusts from 0" to 12"
BASE: 6" round
BULB: Two 40T10
SWITCH: In-line 6" from base
SHADE: 14"
CORD: 9' Brown

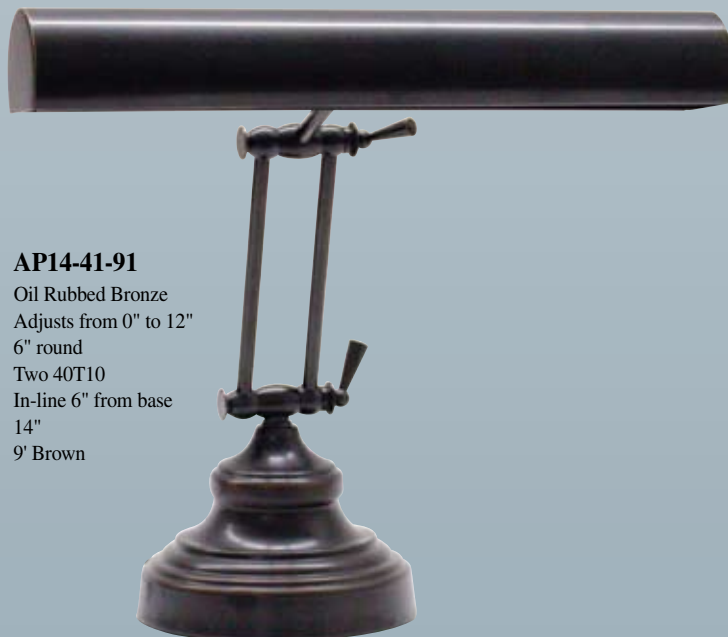

→ **AP14-41-91**

FINISH: Oil Rubbed Bronze
HEIGHT: Adjusts from 0" to 12"
BASE: 6" round
BULB: Two 40T10
SWITCH: In-line 6" from base
SHADE: 14"
CORD: 9' Brown

Advent Collection



← AP14-40-7

FINISH: Black
 HEIGHT: Adjusts from
 3½" to 12½"
 BASE: 6" round
 BULB: Two 40T10
 SWITCH: In-line 6"
 from base
 SHADE: 14"
 CORD: 9' Black



← AP14-40-71

FINISH: Antique Brass
 HEIGHT: Adjusts from
 3½" to 12½"
 BASE: 6" round
 BULB: Two 40T10
 SWITCH: In-line 6" from base
 SHADE: 14"
 CORD: 9' Brown



→ AP14-40-61

FINISH: Polished Brass
 HEIGHT: Adjusts from
 3½" to 12½"
 BASE: 6" round
 BULB: Two 40T10
 SWITCH: In-line 6"
 from base
 SHADE: 14"
 CORD: 9' Brown

→ AP10-20-61

FINISH: Polished Brass
 HEIGHT: Adjusts from
 3½" to 11½"
 BASE: 5" round
 BULB: One 40T10
 SWITCH: On shade
 SHADE: 10"
 CORD: 9' Brown



← AP10-20-7

FINISH: Black
 HEIGHT: Adjusts from
 3½" to 11½"
 BASE: 5" round
 BULB: One 40T10
 SWITCH: On shade
 SHADE: 10"
 CORD: 9' Black



← AP10-20-71

FINISH: Antique Brass
 HEIGHT: Adjusts from
 3½" to 11½"
 BASE: 5" round
 BULB: One 40T10
 SWITCH: On shade
 SHADE: 10"
 CORD: 9' Brown



➔ **AP14-42-61**
 FINISH: Polished Brass with
 Black Marble
 HEIGHT: Adjusts from
 0" to 13 ¼"
 BASE: 6" round
 BULB: Two 40T10
 SWITCH: In-line 6" from base
 SHADE: 14"
 CORD: 9' Brown



➔ **AP10-22-61**
 FINISH: Polished Brass
 with Black Marble
 HEIGHT: Adjusts from
 0" to 11 ¾"
 BASE: 5" round
 BULB: One 40T10
 SWITCH: On shade
 SHADE: 10"
 CORD: 9' Brown



⤴ **AP10-21-71**
 FINISH: Antique Brass
 HEIGHT: Adjusts from
 0" to 10 ½"
 BASE: 5" round
 BULB: One 40T10
 SWITCH: On shade
 SHADE: 10"
 CORD: 9' Brown



⤴ **AP10-21-61**
 FINISH: Polished Brass
 HEIGHT: Adjusts from 0" to 10 ½"
 BASE: 5" round
 BULB: One 40T10
 SWITCH: On shade
 SHADE: 10"
 CORD: 9' Brown



➔ **AP10-21-91**
 FINISH: Oil Rubbed Bronze
 HEIGHT: Adjusts from
 0" to 10 ½"
 BASE: 5" round
 BULB: One 40T10
 SWITCH: On shade
 SHADE: 10"
 CORD: 9' Brown

15" Shades



← P15-80-51

FINISH: Satin Brass
 HEIGHT: Adjusts from 14" to 18"
 BASE: 5½" round
 BULB: Two 40T10
 SWITCH: On base
 SHADE: 15"
 CORD: 9' Clear



→ P1581-5262

FINISH: Satin Nickel with Polished Chrome Column
 HEIGHT: Adjusts from 14" to 18"
 BASE: 5½" Square
 BULB: Two 40T10
 SWITCH: On base
 SHADE: 15"
 CORD: 9' Clear



← P15-80-52

FINISH: Satin Nickel
 HEIGHT: Adjusts from 14" to 18"
 BASE: 5½" round
 BULB: Two 40T10
 SWITCH: On base
 SHADE: 15"
 CORD: 9' Clear



→ P15-83-52

FINISH: Satin Nickel
 HEIGHT: Adjusts from 11" to 16"
 BASE: 5¾" Square
 BULB: Two 40T10
 SWITCH: On base
 SHADE: 15"
 CORD: 9' Clear



← **P16-DO2-617**

FINISH: Polished Brass and Black
 HEIGHT: 15"
 BASE: 3½" x 8⅞" oval
 BULB: Two 40T10 or 60T10
 SWITCH: In-line 6" from base
 SHADE: 16"
 CORD: 9' Black



→ **P16-DO2-627**

FINISH: Chrome and Black
 HEIGHT: 15"
 BASE: 3½" x 8⅞" oval
 BULB: Two 40T10 or 60T10
 SWITCH: In-line 6" from base
 SHADE: 16"
 CORD: 9' Black

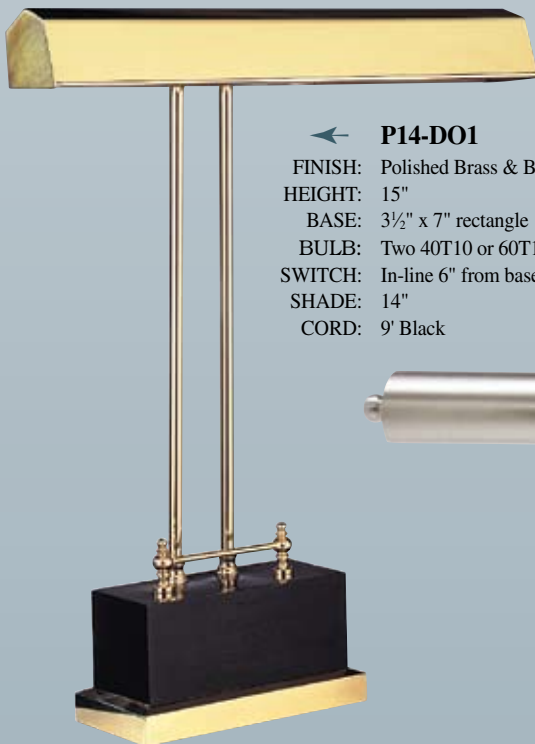

← **P14-DO1**

FINISH: Polished Brass & Black
 HEIGHT: 15"
 BASE: 3½" x 7" rectangle
 BULB: Two 40T10 or 60T10
 SWITCH: In-line 6" from base
 SHADE: 14"
 CORD: 9' Black



→ **P15-90-61**

FINISH: Polished Brass
 HEIGHT: 15½"
 BASE: 3½" x 9" oval
 BULB: Two 40T10
 SWITCH: Full Range
 Dimmer on base
 SHADE: 15"
 CORD: 9' Brown



← **P15-90-52**

FINISH: Satin Nickel
 HEIGHT: 15½"
 BASE: 3½" x 9" oval
 BULB: Two 40T10
 SWITCH: Full Range
 Dimmer on base
 SHADE: 15"
 CORD: 9' Brown

Upright Piano



PF14-250
 FLUORESCENT OPTION
 Uses One F8T5WW Bulb



← **P14-250**

FINISH: Polished Brass
 HEIGHT: Adjusts from 0" to 8"
 BASE: 6" round
 BULB: Two 40T10 or 60T10
 SWITCH: In-line 6" from base
 SHADE: 14"
 CORD: 9' Brown



P10-150

FINISH: Polished Brass
 HEIGHT: Adjusts from 0" to 8"
 BASE: 6" round
 BULB: One 40T10 or 60T10
 SWITCH: On shade
 SHADE: 10"
 CORD: 9' Brown



P14-250-617

FINISH: Black with Polished Brass Accents
 HEIGHT: Adjusts from 0" to 8"
 BASE: 6" round
 BULB: Two 40T10 or 60T10
 SWITCH: In-line 6" from base
 SHADE: 14"
 CORD: 9' Black



P10-150-617

FINISH: Black with Polished Brass Accents
 HEIGHT: Adjusts from 0" to 8"
 BASE: 6" round
 BULB: One 40T10 or 60T10
 SWITCH: On shade
 SHADE: 10"
 CORD: 9' Black



LED Piano



LED SPECIFICATIONS

PIANO LAMPS

Product	CRI	Watts	Lumens	CCT	Lifetime	Equivalent Incandescent
PLED100s	75	2.2	80	3000K	30,000 hrs	40 Watts



→ **PLED100-61**
 FINISH: Polished Brass
 HEIGHT: 16"
 BASE: 5¼" Diameter
 BULB: LED
 SWITCH: Center of Light Bar
 SHADE: 19"
 CORD: 10' Black with Transformer



→ **PLED100-617**
 FINISH: Black with Brass Accents
 HEIGHT: 16"
 BASE: 5¼" Diameter
 BULB: LED
 SWITCH: Center of Light Bar
 SHADE: 19"
 CORD: 10' Black with Transformer



← **PLED100-527**
 FINISH: Black with Satin Nickel Accents
 HEIGHT: 16"
 BASE: 5¼" Diameter
 BULB: LED
 SWITCH: Center of Light Bar
 SHADE: 19"
 CORD: 10' Black with Transformer



↑ **PLED101-61**
 FINISH: Polished Brass
 HEIGHT: 4"
 BASE: 5¼" Diameter
 BULB: LED
 SWITCH: Center of Light Bar
 SHADE: 19"
 CORD: 10' Black with Transformer



↓ **PLED101-617**
 FINISH: Black with Brass Accents
 HEIGHT: 4"
 BASE: 5¼" Diameter
 BULB: LED
 SWITCH: Center of Light Bar
 SHADE: 19"
 CORD: 10' Black with Transformer



← **PLED101-527**
 FINISH: Black with Satin Nickel Accents
 HEIGHT: 4"
 BASE: 5¼" Diameter
 BULB: LED
 SWITCH: Center of Light Bar
 SHADE: 19"
 CORD: 10' Black with Transformer

LED Desk/Piano *New!*

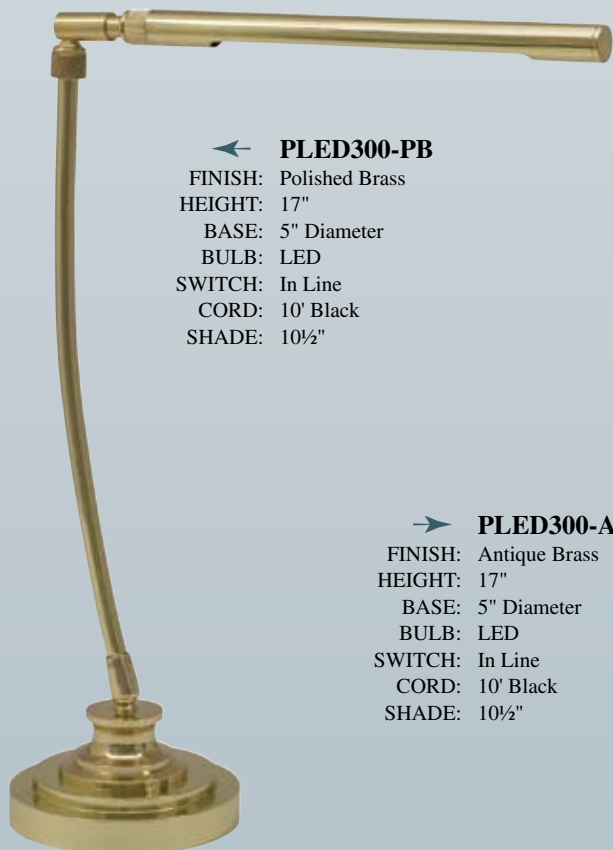

← **PLED300-PB**

FINISH: Polished Brass
 HEIGHT: 17"
 BASE: 5" Diameter
 BULB: LED
 SWITCH: In Line
 CORD: 10' Black
 SHADE: 10½"

→ **PLED300-AB**

FINISH: Antique Brass
 HEIGHT: 17"
 BASE: 5" Diameter
 BULB: LED
 SWITCH: In Line
 CORD: 10' Black
 SHADE: 10½"



← **PLED300-SN**

FINISH: Satin Nickel
 HEIGHT: 17"
 BASE: 5" Diameter
 BULB: LED
 SWITCH: In Line
 CORD: 10' Black
 SHADE: 10½"



→ **PLED300-OB**

FINISH: Oil Rubbed Bronze
 HEIGHT: 17"
 BASE: 5" Diameter
 BULB: LED
 SWITCH: In Line
 CORD: 10' Black
 SHADE: 10½"

LED SPECIFICATIONS

Product	CRI	Watts	Lumens	CCT	Lifetime	Equivalent Incandescent
PLED300s	93	3	72	3400K	30,000 hrs	50 Watts



New!

DESK/PIANO LAMPS



PHOTO SHOWS SWITCH DETAIL ON SHADE



↑ **PLED200-527**
 FINISH: Black w/ Satin Nickel
 HEIGHT: 13 1/2"
 BASE: 5" Diameter
 BULB: LED
 SWITCH: Toggle On Shade
 CORD: 10' Black with Transformer
 SHADE: 14"



↑ **PLED200-617**
 FINISH: Black w/ Brass
 HEIGHT: 13 1/2"
 BASE: 5" Diameter
 BULB: LED
 SWITCH: Toggle On Shade
 CORD: 10' Black with Transformer
 SHADE: 14"



↑ **PLED201-527**
 FINISH: Black w/ Satin Nickel
 HEIGHT: 7"
 BASE: 5" Diameter
 BULB: LED
 SWITCH: Toggle On Shade
 CORD: 10' Black with Transformer
 SHADE: 14"



→ **PLED201-617**
 FINISH: Black w/ Brass
 HEIGHT: 7"
 BASE: 5" Diameter
 BULB: LED
 SWITCH: Toggle On Shade
 CORD: 10' Black with Transformer
 SHADE: 14"

LED SPECIFICATIONS

Product	CRI	Watts	Lumens	CCT	Lifetime	Equivalent Incandescent
PLED200s	93	2.4	57.6	3400K	30,000 hrs	35 Watts

LED Desk/Piano *New!*



↑ **PLED202-AB**
 FINISH: Antique Brass
 HEIGHT: Adjusts from 4" to 10"
 BASE: 6½" Diameter
 BULB: LED
 SWITCH: Toggle On Shade
 CORD: 10' Black with Transformer
 SHADE: 14"



→ **PLED204-MB**
 FINISH: Mahogany Bronze
 HEIGHT: Adjusts from 2" to 13½"
 BASE: 5½" Square
 BULB: LED
 SWITCH: Toggle On Base
 CORD: 10' Black with Transformer
 SHADE: 14"

New Shade Profile used on
 PLED and GPTLED products:
 (1⅜" H x 2⅛" W)



← **PLED203-AB**
 FINISH: Antique Brass
 HEIGHT: Adjusts from 2" to 13½"
 BASE: 5" Diameter
 BULB: LED
 SWITCH: Toggle On Shade
 CORD: 10' Black with Transformer
 SHADE: 14"



→ **PLED203-PB**
 FINISH: Polished Brass
 HEIGHT: Adjusts from 2" to 13½"
 BASE: 5" Diameter
 BULB: LED
 SWITCH: Toggle On Shade
 CORD: 10' Black with Transformer
 SHADE: 14"

LED SPECIFICATIONS

Product	CRI	Watts	Lumens	CCT	Lifetime	Equivalent Incandescent
PLED200s	93	2.4	57.6	3400K	30,000 hrs	35 Watts

LED Grand Piano



PIANO LAMPS



↑ **GPTLED-61**
 FINISH: Polished Brass
 HEIGHT: 3" from top of clamp to top of arm
 CLAMP: Felt-lined, adjusts up to 1½"
 BULB: LED
 SWITCH: Toggle on Shade
 SHADE: 14"
 CORD: 10' Black with transformer

New!



↑ **GPTLED-7**
 FINISH: Black
 HEIGHT: 3" from top of clamp to top of arm
 CLAMP: Felt-lined, adjusts up to 1½"
 BULB: LED
 SWITCH: Toggle on Shade
 SHADE: 14"
 CORD: 10' Black with transformer



→ **GPLED19-7**
 FINISH: Black w/ brass accents
 HEIGHT: 5" from top of clamp to top of arm
 CLAMP: Felt-lined, adjusts up to 1½"
 BULB: LED
 SWITCH: Center of light bar
 SHADE: 19"
 CORD: 10' Black with transformer



↑ **GPLED19-61**
 FINISH: Polished Brass
 HEIGHT: 5" from top of clamp to top of arm
 CLAMP: Felt-lined, adjusts up to 1½"
 BULB: LED
 SWITCH: Center of light bar
 SHADE: 19"
 CORD: 10' Black with transformer

LED SPECIFICATIONS

Product	CRI	Watts	Lumens	CCT	Lifetime	Equivalent Incandescent
GPTLED	93	2.4	57.6	3400K	30,000 hrs	(4) 15 Watts
GPLED	75	2.2	80	3000K	30,000 hrs	(4) 15 Watts
ALED	75	1.9	59.5	8000K	30,000 hrs	(1) 15 Watts

Battery Operated



→ **ALED15-1**
 FINISH: Gold
 HEIGHT: 5"
 CLAMP: 2¾"W x 3"H, Expands to fit surfaces up to ¾" wide.
 BULB: LED
 SWITCH: On back of shade
 SHADE: 15" long
 BATTERIES: 4AA (Not Included)



→ **ALED15-7**
 FINISH: Black
 HEIGHT: 5"
 CLAMP: 2¾"W x 3"H, Expands to fit surfaces up to ¾" wide.
 BULB: LED
 SWITCH: On back of shade
 SHADE: 15" long
 BATTERIES: 4AA (Not Included)

Grand Piano



→ GPXL-617

FINISH: Black w/ Brass Accents
HEIGHT: Adjustable
CLAMP: Felt-lined, adjusts up to 1½"
BULB: Four 15T4
SWITCH: In-line 3" from clamp
SHADE: 1" x 22" Rotating
CORD: 10' Black



↑ GPXL-627

FINISH: Black w/ Chrome Accents
HEIGHT: Adjustable
CLAMP: Felt-lined, adjusts up to 1½"
BULB: Four 15T4
SWITCH: In-line 3" from clamp
SHADE: 1" x 22" Rotating
CORD: 10' Black



↑ GPXL22-61

FINISH: Polished Brass
HEIGHT: Adjustable
CLAMP: Felt-lined, adjusts up to 1½"
BULB: Four 15T4
SWITCH: In-line 3" from clamp
SHADE: 1" x 22" Rotating
CORD: 10' Brown

→ **GP10-7**

FINISH: Black
 HEIGHT: Adjustable 8½"
 gooseneck
 CLAMP: Felt-lined,
 adjusts from ½" to 1"
 BULB: One 40T10 or 60T10
 SWITCH: On shade
 SHADE: 10"
 CORD: 9' Black



↑ **GP10-61**

FINISH: Polished Brass
 HEIGHT: Adjustable 8½"
 gooseneck
 CLAMP: Felt-lined,
 adjusts from ½" to 1"
 BULB: One 40T10 or 60T10
 SWITCH: On shade
 SHADE: 10"
 CORD: 9' Brown

← **GP10-81**

FINISH: Mahogany Bronze
 HEIGHT: Adjustable 8½"
 gooseneck
 CLAMP: Felt-lined,
 adjusts from ½" to 1"
 BULB: One 40T10 or 60T10
 SWITCH: On shade
 SHADE: 10"
 CORD: 9' Brown



↑ **GP14-81**

FINISH: Mahogany Bronze
 HEIGHT: Adjustable 8½" gooseneck
 CLAMP: Felt-lined,
 adjusts from ½" to 1"
 BULB: Two 40T10 or 60T10
 SWITCH: In-line 3" from clamp
 SHADE: 14"
 CORD: 9' Brown



↑ **GP14-7**

FINISH: Black
 HEIGHT: Adjustable 8½"
 gooseneck
 CLAMP: Felt-lined,
 adjusts from ½" to 1"
 BULB: Two 40T10 or 60T10
 SWITCH: In-line 3" from clamp
 SHADE: 14"
 CORD: 9' Black

← **GP14-61**

FINISH: Polished Brass
 HEIGHT: Adjustable 8½"
 gooseneck
 CLAMP: Felt-lined,
 adjusts from ½" to 1"
 BULB: Two 40T10 or 60T10
 SWITCH: In-line 3" from clamp
 SHADE: 14"
 CORD: 9' Brown

Counter Balance



➔ **P10-191-71**

FINISH: Antique Brass
 HEIGHT: Adjusts 0" to 26"
 BASE: 5" Square
 BULB: 13W-PL fluorescent
 SWITCH: On base
 SHADE: 10"
 CORD: 11' Black with transformer



⤴ **P10-191-81**

FINISH: Mahogany Bronze
 HEIGHT: Adjusts 0" to 26"
 BASE: 5" Square
 BULB: 13W-PL fluorescent
 SWITCH: On base
 SHADE: 10"
 CORD: 11' Black with transformer



⤴ **P10-191-61**

FINISH: Polished Brass
 HEIGHT: Adjusts from 0" to 26"
 BASE: 5" Square
 BULB: 13W-PL fluorescent
 SWITCH: On base
 SHADE: 10"
 CORD: 11' black with transformer

➔ **P10-191-61C**

FINISH: Polished Brass & Crystal
 HEIGHT: Adjusts from 0" to 26"
 BASE: 5" Square
 BULB: 13W-PL fluorescent
 SWITCH: On base
 SHADE: 10"
 CORD: 11' black with transformer



PIANO LAMPS

➔ **PS10-190-M (long arm)**

FINISH: Polished Brass & Black Marble
 HEIGHT: Adjusts from 0" to 26"
 BASE: 5" Square
 BULB: 13W-PL fluorescent
 SWITCH: On base
 SHADE: 10"
 CORD: 11' black with transformer

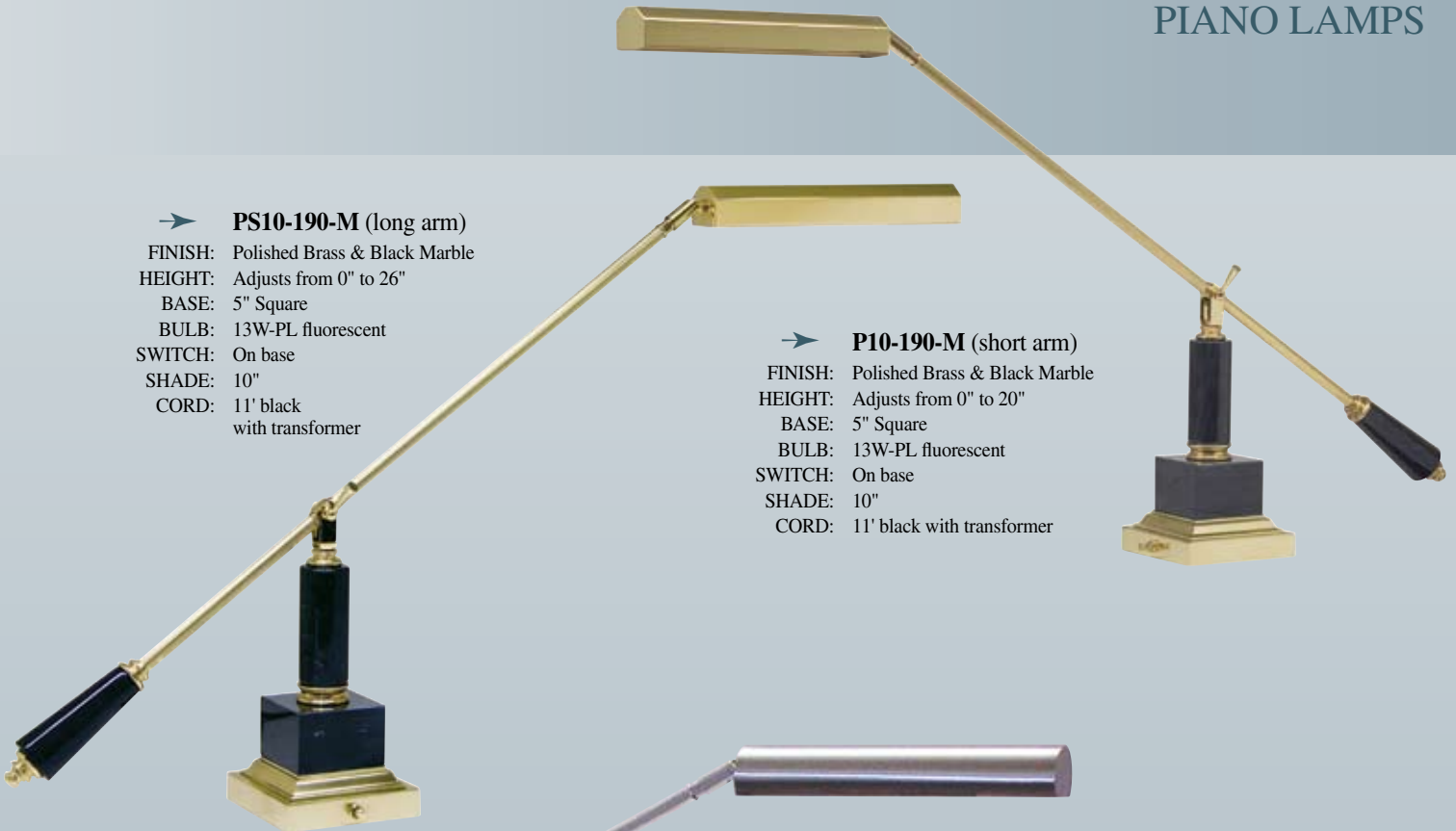

➔ **P10-190-M (short arm)**

FINISH: Polished Brass & Black Marble
 HEIGHT: Adjusts from 0" to 20"
 BASE: 5" Square
 BULB: 13W-PL fluorescent
 SWITCH: On base
 SHADE: 10"
 CORD: 11' black with transformer

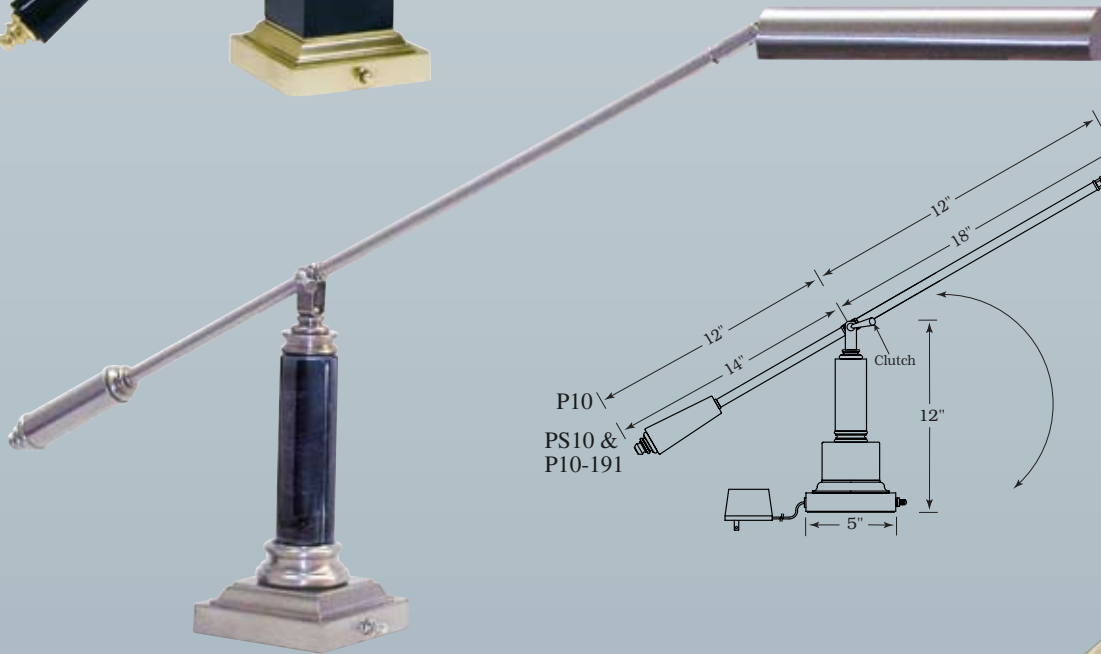

↑ **P10-191-52M**

FINISH: Satin Nickel & Black Marble
 HEIGHT: Adjusts from 0" to 26"
 BASE: 5" Square
 BULB: 13W-PL fluorescent
 SWITCH: On base
 SHADE: 10"
 CORD: 11' black with transformer

↑ **P10-191-61M**

FINISH: Polished Brass & Black Marble
 HEIGHT: Adjusts from 0" to 26"
 BASE: 5" Square
 BULB: 13W-PL fluorescent
 SWITCH: On base
 SHADE: 10"
 CORD: 11' black with transformer



FLUORESCENT SPECIFICATIONS

Product	CRI	Watts	Lumens	CCT	Equivalent Incandescent
P10-190 P10-191	82	13	688	2700K	55 Watts

Counter Balance



← FL10-MB

FINISH: Mahogany Bronze
 HEIGHT: Adjusts 26" to 54"
 BASE: 10" Round
 BULB: One 60T10
 SWITCH: On Socket
 SHADE: 10"
 CORD: 10' Black



PFL-617

FINISH: Black & Polished Brass
 HEIGHT: Adjusts 26" to 54"
 BASE: 10" Round
 BULB: One 60T10
 SWITCH: On Socket
 SHADE: 10"
 CORD: 10' Black



← PFL-527

FINISH: Satin Nickel & Black
 HEIGHT: Adjusts 26" to 54"
 BASE: 10" Round
 BULB: One 60T10
 SWITCH: On Socket
 SHADE: 10"
 CORD: 10' Black



← FL10-GT

FINISH: Granite
 HEIGHT: Adjusts 26" to 54"
 BASE: 10" Round
 BULB: One 60T10
 SWITCH: On Socket
 SHADE: 10"
 CORD: 10' Black



↑ **P10-192-627**
 FINISH: Chrome w/ Black
 HEIGHT: Adjusts from 0" to 21"
 BASE: 6" round
 BULB: One 40T10 or 60T10
 SWITCH: On Socket
 SHADE: 10"
 CORD: 9' Black



→ **P10-192-617**
 FINISH: Polished Brass w/ Black
 HEIGHT: Adjusts from 0" to 21"
 BASE: 6" round
 BULB: One 40T10 or 60T10
 SWITCH: On Socket
 SHADE: 10"
 CORD: 9' Black



↑ **P10-007-617**
 FINISH: Polished Brass w/ Black
 HEIGHT: Adjusts from 0" to 21"
 BASE: 6" round
 BULB: One 40T10 or 60T10
 SWITCH: On Socket
 SHADE: 10"
 CORD: 9' Black

→ **P10-007-627**
 FINISH: Chrome w/ Black
 HEIGHT: Adjusts from 0" to 21"
 BASE: 6" round
 BULB: One 40T10 or 60T10
 SWITCH: On Socket
 SHADE: 10"
 CORD: 9' Black

Barrister Collection *New!*



↑ **BAR103-BB**

FINISH: Belgian Bronze
 HEIGHT: 23½"
 BASE: 9½" Diameter
 BULB: (2) 60W G10
 SWITCH: In-Line
 CORD: 10' Brown
 SHADE: 10" x 15" x 7½"
 Black Parchment
 Gold Lining



↑ **BAR102-BB**

FINISH: Belgian Bronze
 HEIGHT: 26"
 BASE: 9½" x 5" Rectangle
 BULB: 100W Type A
 SWITCH: In-Line
 CORD: 10' Brown
 SHADE: (7" x 10") x (10" x 15") x 9"
 Black Parchment
 Gold Lining



→ **BAR101-BB**

FINISH: Belgian Bronze
 HEIGHT: 26"
 BASE: 5½" Square
 BULB: 100W 3-way
 SWITCH: On Socket
 CORD: 10' Brown
 SHADE: 8" x 13" x 9"
 Black Parchment
 Gold Lining



→ **BAR125-BB**

FINISH: Belgian Bronze
 DEPTH: 8"
 HEIGHT: 16"
 BULB: 100W Type A
 SHADE: 5" x 9" x 8"
 Black Parchment
 Gold Lining
 BACKPLATE: 4¾" Diameter
 Direct Wire Only

Club Collection

TABLE/WALL LAMPS



← CL225-AS

FINISH: Antique Silver
HEIGHT: 16"
ARM: Extends 12"
BULB: One 100W 3-way
SWITCH: On Socket
SHADE: 6½" x 13" x 10"
White Softback
CORD: 10' Ivory, 30" cord cover
BACKPLATE: 2¾" x 5¾"



↑ CL225-AB

FINISH: Antique Brass
HEIGHT: 16"
ARM: Extends 12"
BULB: One 100W 3-way
SWITCH: On Socket
SHADE: 6½" x 13" x 10"
Off-white Softback
CORD: 10' Ivory, 30" cord cover
BACKPLATE: 2¾" x 5¾"



↑ CL225-OB

FINISH: Oil Rubbed Bronze
HEIGHT: 16"
ARM: Extends 12"
BULB: One 100W 3-way
SWITCH: On Socket
SHADE: 6½" x 13" x 10"
Off-white Softback
CORD: 10' Ivory, 30" cord cover
BACKPLATE: 2¾" x 5¾"

Cover plate provided for standard junction box when necessary, as shown on CL225-AB.

Club Collection



↑ **CL-251-AS**

FINISH: Antique Silver
 HEIGHT: 25"
 BASE: 7" Round
 ARM: Extends 12"
 BULB: One 60W Type A
 SWITCH: On Socket
 SHADE: White Softback
 6½" x 13" x 10"
 CORD: 10' Clear



↑ **CL-250-AB**

FINISH: Antique Brass
 HEIGHT: 25" to 31"
 BASE: 7" Round
 BULB: One 100W Type A
 SWITCH: On Socket
 SHADE: Off-white Softback
 6½" x 13" x 10"
 CORD: 10' Brown



← **CL251-AB**

FINISH: Antique Brass
 HEIGHT: 25"
 BASE: 7" Round
 ARM: Extends 12"
 BULB: One 60W Type A
 SWITCH: On Socket
 SHADE: Off-white Softback
 6½" x 13" x 10"
 CORD: 10' Brown



← **CL251-OB**

FINISH: Oil Rubbed Bronze
 HEIGHT: 25"
 BASE: 7" Round
 ARM: Extends 12"
 BULB: One 60W Type A
 SWITCH: On Socket
 SHADE: Off-white Softback
 6½" x 13" x 10"
 CORD: 10' Brown

FLOOR/TABLE LAMPS



← **CL250-AS**

FINISH: Antique Silver
 HEIGHT: 25" to 31"
 BASE: 7" Round
 BULB: One 100W Type A
 SWITCH: On Socket
 SHADE: White Softback
 6½" x 13" x 10"
 CORD: 10' Clear



→ **CL202-OB**

FINISH: Oil rubbed bronze
 HEIGHT: Adjusts 46" to 70"
 BASE: 10" Diameter
 BULB: 100W 3-way
 SWITCH: On Socket
 SHADE: Off-white Softback
 6½" x 13" x 10"
 CORD: 10' Brown
 TABLE: 12" Diameter



← **CL202-AB**

FINISH: Antique Brass
 HEIGHT: Adjusts 46" to 70"
 BASE: 10" Diameter
 BULB: 100W 3-way
 SWITCH: On Socket
 SHADE: Off-white Softback
 6½" x 13" x 10"
 CORD: 10' Brown
 TABLE: 12" Diameter



→ **CL250-OB**

FINISH: Oil Rubbed Bronze
 HEIGHT: 25" to 31"
 BASE: 7" Round
 BULB: One 100W Type A
 SWITCH: On Socket
 SHADE: Off-white Softback
 6½" x 13" x 10"
 CORD: 10' Brown



↑ **CL202-AS**

FINISH: Antique Silver
 HEIGHT: Adjusts 46" to 70"
 BASE: 10" Diameter
 BULB: 100W 3-way
 SWITCH: On Socket
 SHADE: White Softback
 6½" x 13" x 10"
 CORD: 10' Clear
 TABLE: 12" Diameter

Club Collection



→ **CL201-AS**
FINISH: Antique Silver
HEIGHT: 45" to 59"
BASE: 12" Round
BULB: One 100W 3-way
SWITCH: On Socket
SHADE: White Softback
6½" x 13" x 10"
CORD: 10' Clear



→ **CL201-AB**
FINISH: Antique Brass
HEIGHT: 45" to 59"
BASE: 12" Round
BULB: One 100W 3-way
SWITCH: On Socket
SHADE: Off-white Softback
6½" x 13" x 10"
CORD: 10' Brown

→ **CL201-OB**
FINISH: Oil Rubbed Bronze
HEIGHT: 45" to 59"
BASE: 12" Round
BULB: One 100W 3-way
SWITCH: On Socket
SHADE: Off-white Softback
6½" x 13" x 10"
CORD: 10' Brown



FLOOR LAMPS



↑ **CL200-AB**

FINISH: Antique Brass
 HEIGHT: 45" to 59"
 ARM: Extends 12"
 BASE: 12" Round
 BULB: One 100W 3-way
 SWITCH: On Socket
 SHADE: Off-white Softback
 6½" x 13" x 10"
 CORD: 10' Brown



→ **CL200-AS**

FINISH: Antique Silver
 HEIGHT: 45" to 59"
 ARM: Extends 12"
 BASE: 12" Round
 BULB: One 100W 3-way
 SWITCH: On Socket
 SHADE: White Softback
 6½" x 13" x 10"
 CORD: 10' Clear

← **CL200-OB**

FINISH: Oil Rubbed Bronze
 HEIGHT: 45" to 59"
 ARM: Extends 12"
 BASE: 12" Round
 BULB: One 100W 3-way
 SWITCH: On Socket
 SHADE: Off-white Softback
 6½" x 13" x 10"
 CORD: 10' Brown

Coach Collection *New!*



→ **CH850-AB**
 FINISH: Antique Brass
 HEIGHT: 30¼"
 BASE: 8" Diameter
 BULB: 100W 3-way
 SWITCH: On Socket
 CORD: 10' Gold
 SHADE: 14"x 15" x 10"
 Off White Silk Softback



↑ **CH850-OB**
 FINISH: Oil Rubbed Bronze
 HEIGHT: 30¼"
 BASE: 8" Diameter
 BULB: 100W 3-way
 SWITCH: On Socket
 CORD: 10' Brown
 SHADE: 14"x 15" x 10"
 Off White Silk Softback



→ **CH850-AS**
 FINISH: Antique Silver
 HEIGHT: 30¼"
 BASE: 8" Diameter
 BULB: 100W 3-way
 SWITCH: On Socket
 CORD: 10' Silver
 SHADE: 14"x 15" x 10"
 White Silk Softback



← **CH879-AB**
 FINISH: Antique Brass
 HEIGHT: 18"
 BASE: 4¾" Diameter
 BULB: 60W-B10 Candelabra
 SWITCH: In-Line
 CORD: 10' Gold
 SHADE: 4"x 6" x 6"
 Off White Hardback

New!



↑ **CH876-AB**
 FINISH: Antique Brass
 HEIGHT: 12½"
 BASE: 6" x 4" Rectangle
 BULB: 60W Type A
 SWITCH: In-Line
 CORD: 10' Gold
 SHADE: (6"x 4") x (10" x 6") x 7"
 Off White Hardback



← **CH880-OB**
 FINISH: Oil Rubbed Bronze
 HEIGHT: 15"
 BASE: 6" x 4" Rectangle
 BULB: (2) 60W-B10 Candelabra
 SWITCH: In-Line
 CORD: 10' Brown
 SHADE: (4"x 6") x (8" x 12") x 6"
 Off White Hardback



→ **CH877-AS**
 FINISH: Antique Silver
 HEIGHT: 13½"
 BASE: 4¾" Diameter
 BULB: 60W-B10 Candelabra
 SWITCH: In-Line
 CORD: 10' Silver
 SHADE: 6"x 8" x 6"
 White Hardback



← **CH878-AS**
 FINISH: Antique Silver
 HEIGHT: 12"
 BASE: 4¾" Diameter
 BULB: 60W-B10 Candelabra
 SWITCH: In-Line
 CORD: 10' Silver
 SHADE: 4"x 6" x 6"
 White Hardback



← **CH875-OB**
 FINISH: Oil Rubbed Bronze
 HEIGHT: 14"
 BASE: 5¼" Diameter
 BULB: 60W Type A
 SWITCH: In-Line
 CORD: 10' Brown
 SHADE: 6"x 9" x 7"
 Off White Hardback

Coach Collection *New!*



← **CH825-AB**

FINISH: Antique Brass
 ARM EXT: 14"
 HEIGHT: Adjusts 35 1/2" to 52 1/2"
 BASE: 10" Diameter
 BULB: 60W Type A
 SWITCH: On Socket
 CORD: 10' Gold
 SHADE: 7"x 4" x 3 1/4" Metal



← **CH825-OB**

FINISH: Oil Rubbed Bronze
 ARM EXT: 14"
 HEIGHT: Adjusts 35 1/2" to 52 1/2"
 BASE: 10" Diameter
 BULB: 60W Type A
 SWITCH: On Socket
 CORD: 10' Brown
 SHADE: 7"x 4" x 3 1/4" Metal



↑ **CH825-AS**

FINISH: Antique Silver
 ARM EXT: 14"
 HEIGHT: Adjusts 35 1/2" to 52 1/2"
 BASE: 10" Diameter
 BULB: 60W Type A
 SWITCH: On Socket
 CORD: 10' Silver
 SHADE: 7"x 4" x 3 1/4" Metal

NOTE: Cord exits from adjustment arm.

New!

FLOOR LAMPS

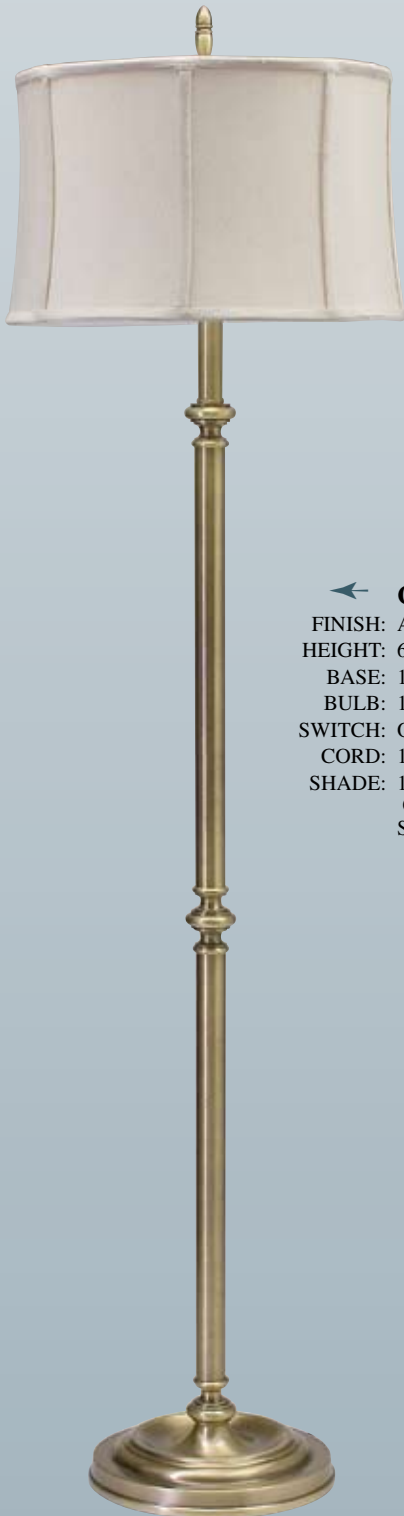

← **CH800-AB**

FINISH: Antique Brass
HEIGHT: 61"
BASE: 10" Diameter
BULB: 150W 3-way
SWITCH: On Socket
CORD: 10' Gold
SHADE: 15"x 16" x 10"
Off White Silk
Softback



→ **CH800-OB**

FINISH: Oil Rubbed Bronze
HEIGHT: 61"
BASE: 10" Diameter
BULB: 150W 3-way
SWITCH: On Socket
CORD: 10' Brown
SHADE: 15"x 16" x 10"
Off White Silk
Softback



← **CH800-AS**

FINISH: Antique Silver
HEIGHT: 61"
BASE: 10" Diameter
BULB: 150W 3-way
SWITCH: On Socket
CORD: 10' Silver
SHADE: 15"x 16" x 10"
White Silk
Softback

Flex Collection



↑ **FLX150-BLK**

FINISH: Black with Antique Brass
 HEIGHT: 25"
 BASE: 7½" Diameter
 BULB: 100W 3-way
 SWITCH: On Socket
 CORD: 10' Black
 SHADE: Off-white Linen
 Hardback 5" x 9" x 7"



↑ **FLX150-AB**

FINISH: Antique Brass
 HEIGHT: 25"
 BASE: 7½" Diameter
 BULB: 100W 3-way
 SWITCH: On Socket
 CORD: 10' Brown
 SHADE: Off-white Linen
 Hardback 5" x 9" x 7"



→ **FLX150-CHB**

FINISH: Chestnut Bronze
 with Chrome
 HEIGHT: 25"
 BASE: 7½" Diameter
 BULB: 100W 3-way
 SWITCH: On Socket
 CORD: 10' Black
 SHADE: White Linen
 Hardback 5" x 9" x 7"



→ **FLX125-CH**

FINISH: Chrome
 ARM: 12"
 BULB: 100W 3-way
 SWITCH: On Socket
 SHADE: 5" x 9" x 7"
 White Linen Hardback
 CORD: 10' Ivory, 30" Cord Cover
 BACKPLATE: 6" Diameter



→ **FLX125-AB**

FINISH: Antique Brass
 ARM: 12"
 BULB: 100W 3-way
 SWITCH: On Socket
 SHADE: 5" x 9" x 7"
 Off-white Linen Hardback
 CORD: 10' Ivory, 30" Cord Cover
 BACKPLATE: 6" Diameter



FLX100-CHB

FINISH: Chestnut Bronze with Chrome
 HEIGHT: 56½"
 ARM: 12"
 BASE: 10¼" Diameter
 BULB: 100W 3-way
 SWITCH: On Socket
 CORD: 10' Black
 SHADE: 6" x 10" x 9"
 White Linen Hardback



FLX100-AB

FINISH: Antique Brass
 HEIGHT: 56½"
 ARM: 12"
 BASE: 10¼" Diameter
 BULB: 100W 3-way
 SWITCH: On Socket
 CORD: 10' Brown
 SHADE: 6" x 10" x 9"
 Off-white Linen Hardback



FLX100-BLK

FINISH: Black with Antique Brass
 HEIGHT: 56½"
 ARM: 12"
 BASE: 10¼" Diameter
 BULB: 100W 3-way
 SWITCH: On Socket
 CORD: 10' Black
 SHADE: 6" x 10" x 9"
 Off-white Linen Hardback

Generation Collection



↓ **G175-GT**

FINISH: Granite
 ARM: 10"
 BACKPLATE: 5 1/4" Diameter
 BULB: 50W GU10
 SWITCH: Full Range Dimmer In Shade
 SHADE: 6 1/2" x 3 1/4" x 1 1/2"
 CORD: 10' Ivory, 30" cord cover



↑ **G175-CHB**

FINISH: Chestnut Bronze
 ARM: 10"
 BACKPLATE: 5 1/4" Diameter
 BULB: 50W GU10
 SWITCH: Full Range Dimmer In Shade
 SHADE: 6 1/2" x 3 1/4" x 1 1/2"
 CORD: 10' Ivory, 30" cord cover



↑ **G275-CHB**

FINISH: Chestnut Bronze
 HEIGHT: 13 3/4"
 ARM: 10 1/4"
 BACKPLATE: 5 1/4" Diameter
 BULB: 100W Type A
 SWITCH: Full Range Dimmer On Socket
 SHADE: Off-White Linen Hardback
 8 1/2" x 11 1/2" x 9"
 CORD: 10' Ivory, 30" cord cover

↑ **G275-HB**

FINISH: Hammered Bronze
 HEIGHT: 13 3/4"
 ARM: 10 1/4"
 BACKPLATE: 5 1/4" Diameter
 BULB: 100W Type A
 SWITCH: Full Range Dimmer On Socket
 SHADE: Off-white Linen Hardback
 8 1/2" x 11 1/2" x 9"
 CORD: 10' Ivory, 30" cord cover



→ **G275-GT**

FINISH: Granite
 HEIGHT: 13 3/4"
 ARM: 10 1/4"
 BACKPLATE: 5 1/4" Diameter
 BULB: 100W Type A
 SWITCH: Full Range Dimmer On Socket
 SHADE: White Linen Hardback
 8 1/2" x 11 1/2" x 9"
 CORD: 10' Ivory, 30" cord cover

↑ **G275-WT**

FINISH: White
 HEIGHT: 13 3/4"
 ARM: 10 1/4"
 BACKPLATE: 5 1/4" Diameter
 BULB: 100W Type A
 SWITCH: Full Range Dimmer on Column
 SHADE: White Linen Hardback
 8 1/2" x 11 1/2" x 9"
 CORD: 10' White, 30" cord cover



← **G250-HB**
 FINISH: Hammered Bronze
 HEIGHT: 25½"
 BASE: 6" Diameter
 BULB: 100W Type A
 SWITCH: Full Range Dimmer
 SHADE: Off White Linen
 Hardback
 8½" x 11½" x 9"
 CORD 10' Brown



→ **G250-GT**
 FINISH: Granite
 HEIGHT: 25½"
 BASE: 6" Diameter
 BULB: 100W Type A
 SWITCH: Full Range Dimmer
 SHADE: White Linen Hardback
 8½" x 11½" x 9"
 CORD 10' Black



↑ **G250-CHB**
 FINISH: Chestnut Bronze
 HEIGHT: 25½"
 BASE: 6" diameter
 BULB: 100W Type A
 SWITCH: Full Range Dimmer
 SHADE: Off-White Linen Hardback
 8½" x 11½" x 9"
 CORD 10' Brown



← **G250-WT**
 FINISH: White
 HEIGHT: 25½"
 BASE: 6" Diameter
 BULB: 100W Type A
 SWITCH: Full Range Dimmer
 SHADE: White Linen Hardback
 8½" x 11½" x 9"
 CORD 10' White



↑ **G150-CHB**
 FINISH: Chestnut Bronze
 HEIGHT: Adjusts 11½" to 17½"
 BASE: 6" Diameter
 BULB: 50W GU10
 SWITCH: Full Range Dimmer
 In Shade
 SHADE: 6½" x 3¼" x 1½"
 CORD: 10' Brown



→ **G150-GT**
 FINISH: Granite
 HEIGHT: Adjusts 11½" to 17½"
 BASE: 6" Diameter
 BULB: 50W GU10
 SWITCH: Full Range Dimmer
 In Shade
 SHADE: 6½" x 3¼" x 1½"
 CORD: 10' Black

Generation Collection

➔ **G200-CHB**

FINISH: Chestnut Bronze
 HEIGHT: Adjusts 47" to 60"
 BASE: 10" Diameter
 BULB: 150W Type A
 SWITCH: Full Range Dimmer
 SHADE: Off-white Linen
 11" x 13" x 9"
 CORD: 10' Brown



➔ **G100-GT**

FINISH: Granite
 HEIGHT: Adjusts 32 1/2" to 45"
 BASE: 10" Diameter
 BULB: 50W GU10
 SWITCH: Full Range Dimmer
 In Shade
 SHADE: 6 1/2" x 3 1/4" x 1 1/2"
 CORD: 10' Black



⤴ **G200-HB**

FINISH: Hammered Bronze
 HEIGHT: Adjusts 47" to 60"
 BASE: 10" Diameter
 BULB: 50W GU10
 SWITCH: Full Range Dimmer
 SHADE: Off-white Linen
 11" x 13" x 9"
 CORD: 10' Brown



➔ **G200-GT**

FINISH: Granite
 HEIGHT: Adjusts 47" to 60"
 BASE: 10" Diameter
 BULB: 150W Type A
 SWITCH: Full Range Dimmer
 SHADE: White Linen
 11" x 13" x 9"
 CORD: 10' Black



⤵ **G200-WT**

FINISH: White
 HEIGHT: Adjusts 47" to 60"
 BASE: 10" Diameter
 BULB: 150W Type A
 SWITCH: Full Range Dimmer
 SHADE: White Linen
 11" x 13" x 9"
 CORD: 10' White



➔ **G100-CHB**

FINISH: Chestnut Bronze
 HEIGHT: Adjusts 32 1/2" to 45"
 BASE: 10" Diameter
 BULB: 50W GU10
 SWITCH: Full Range Dimmer
 In Shade
 SHADE: 6 1/2" x 3 1/4" x 1 1/2"
 CORD: 10' Brown

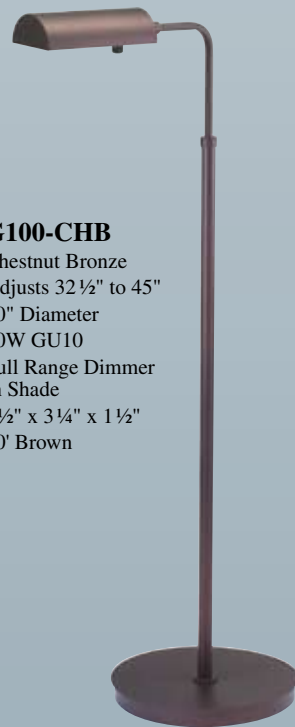



New!

← **G300-HB**

FINISH: Hammered Bronze
 HEIGHT: Adjusts 37" to 46 1/2"
 BASE: 6" x 7 1/4"
 BULB: LED
 SWITCH: On Shade
 SHADE: 11 1/4"
 CORD: 10' Brown

← **G300-BLK**

FINISH: Black
 HEIGHT: Adjusts 37" to 46 1/2"
 BASE: 6" x 7 1/4"
 BULB: LED
 SWITCH: On Shade
 SHADE: 11 1/4"
 CORD: 10' Black



← **G300-GT**

FINISH: Granite
 HEIGHT: Adjusts 37" to 46 1/2"
 BASE: 6" x 7 1/4"
 BULB: LED
 SWITCH: On Shade
 SHADE: 11 1/4"
 CORD: 10' Black

↑ **G300-WT**

FINISH: White
 HEIGHT: Adjusts 37" to 46 1/2"
 BASE: 6" x 7 1/4"
 BULB: LED
 SWITCH: On Shade
 SHADE: 11 1/4"
 CORD: 10' White

→ **G300-CHB**

FINISH: Chestnut Bronze
 HEIGHT: Adjusts 37" to 46 1/2"
 BASE: 6" x 7 1/4"
 BULB: LED
 SWITCH: On Shade
 SHADE: 11 1/4"
 CORD: 10' Brown

LED SPECIFICATIONS

Product	CRI	Watts	Lumens	CCT	Lifetime	Equivalent Incandescent
G300s	60	3.6	250	3000K	50,000 hrs	50 Watts

Generation Collection *New!*

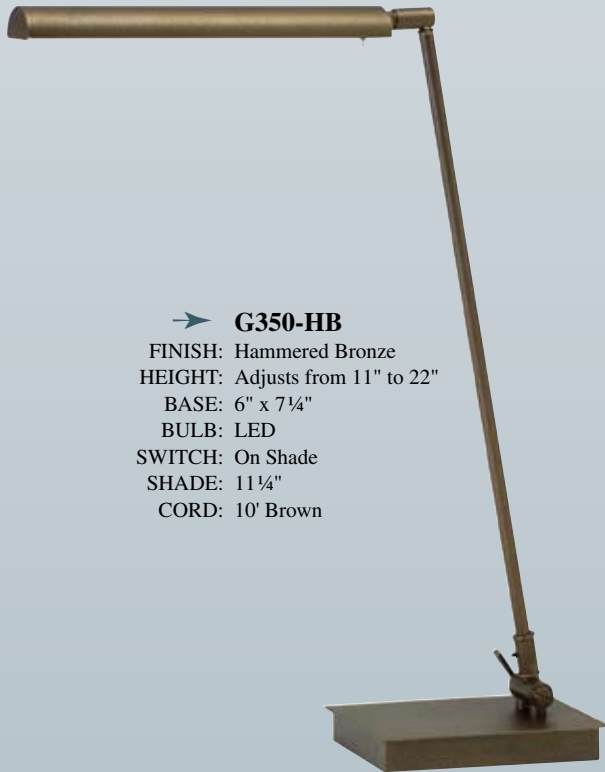

→ **G350-HB**
 FINISH: Hammered Bronze
 HEIGHT: Adjusts from 11" to 22"
 BASE: 6" x 7¼"
 BULB: LED
 SWITCH: On Shade
 SHADE: 11¼"
 CORD: 10' Brown



→ **G350-BLK**
 FINISH: Black
 HEIGHT: Adjusts from 11" to 22"
 BASE: 6" x 7¼"
 BULB: LED
 SWITCH: On Shade
 SHADE: 11¼"
 CORD: 10' Black

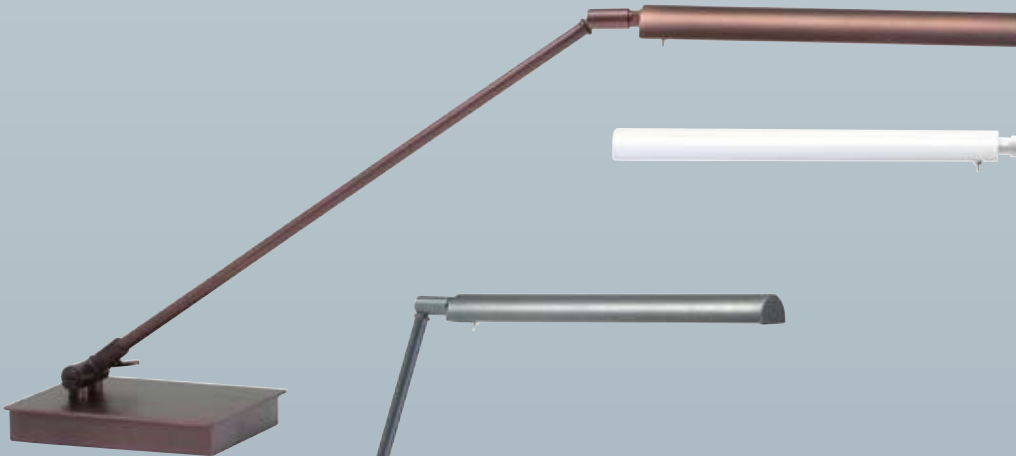

↑ **G350-CHB**
 FINISH: Chestnut Bronze
 HEIGHT: Adjusts from 11" to 22"
 BASE: 6" x 7¼"
 BULB: LED
 SWITCH: On Shade
 SHADE: 11¼"
 CORD: 10' Brown



← **G350-GT**
 FINISH: Granite
 HEIGHT: Adjusts from 11" to 22"
 BASE: 6" x 7¼"
 BULB: LED
 SWITCH: On Shade
 SHADE: 11¼"
 CORD: 10' Black



→ **G350-WT**
 FINISH: White
 HEIGHT: Adjusts from 11" to 22"
 BASE: 6" x 7¼"
 BULB: LED
 SWITCH: On Shade
 SHADE: 11¼"
 CORD: 10' White

LED SPECIFICATIONS

Product	CRI	Watts	Lumens	CCT	Lifetime	Equivalent Incandescent
G300s	60	3.6	250	3000K	50,000 hrs	50 Watts

TABLE/WALL LAMPS

New!

LED SPECIFICATIONS

Product	CRI	Watts	Lumens	CCT	Lifetime	Equivalent Incandescent
G300s	60	3.6	250	3000K	50,000 hrs	50 Watts



↑ **G375-BLK**

FINISH: Black
 PROJECTION: Extends 24½"
 BACKPLATE: 5" x 5"
 BULB: LED
 SWITCH: On Shade
 SHADE: 11¼"
 CORD: 10' Ivory
 30" Cord Cover



↑ **G375-HB**

FINISH: Hammered Bronze
 PROJECTION: Extends 24½"
 BACKPLATE: 5" x 5"
 BULB: LED
 SWITCH: On Shade
 SHADE: 11¼"
 CORD: 10' Ivory
 30" Cord Cover

→ **G375-CHB**

FINISH: Chestnut Bronze
 PROJECTION: Extends 24½"
 BACKPLATE: 5" x 5"
 BULB: LED
 SWITCH: On Shade
 SHADE: 11¼"
 CORD: 10' Ivory
 30" Cord Cover

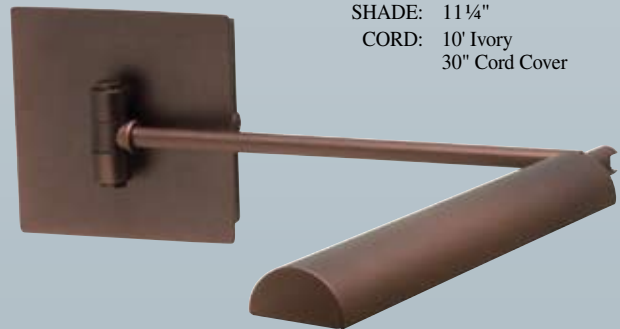

← **G375-GT**

FINISH: Granite
 PROJECTION: Extends 24½"
 BACKPLATE: 5" x 5"
 BULB: LED
 SWITCH: On Shade
 SHADE: 11¼"
 CORD: 10' Ivory
 30" Cord Cover

→ **G375-WT**

FINISH: White
 PROJECTION: Extends 24½"
 BACKPLATE: 5" x 5"
 BULB: LED
 SWITCH: On Shade
 SHADE: 11¼"
 CORD: 10' White
 30" Cord Cover



Grand Isle Collection *New!*



↑ **GI750-AB**

FINISH: Antique Brass
HEIGHT: 24½"
BASE: 6½"
BULB: 100W Type A
SWITCH: Hi-lo On Cord
6" from Base
SHADE: Opal Glass
10" x 7¼"
CORD: 10' Brown



↑ **GI750-OB**

FINISH: Oil Rubbed Bronze
HEIGHT: 24½"
BASE: 6½"
BULB: 100W Type A
SWITCH: Hi-lo On Cord
6" from Base
SHADE: Opal Glass
10" x 7¼"
CORD: 10' Brown

New!



→ **GI751-AB**
 FINISH: Antique Brass
 HEIGHT: 16½"
 BASE: 5½"
 BULB: 60W B10
 SWITCH: Hi-lo On Cord
 6" from Base
 SHADE: Opal Glass
 7" x 5¾"
 CORD: 10' Brown



← **GI751-OB**
 FINISH: Oil Rubbed Bronze
 HEIGHT: 16½"
 BASE: 5½"
 BULB: 60W B10
 SWITCH: Hi-lo On Cord
 6" from Base
 SHADE: Opal Glass
 7" x 5¾"
 CORD: 10' Brown



← **GI775-OB**
 FINISH: Oil Rubbed Bronze
 HEIGHT: 16½"
 ARM: Extends 9"
 BACKPLATE: 5½" Diameter
 BULB: 60W B10
 SWITCH: In-line
 12" from Backplate
 SHADE: Opal Glass
 7" x 5¾"
 CORD: 10' White



→ **GI775-AB**
 FINISH: Antique Brass
 HEIGHT: 16½"
 ARM: Extends 9"
 BACKPLATE: 5½" Diameter
 BULB: 60W B10
 SWITCH: In-line
 12" from Backplate
 SHADE: Opal Glass
 7" x 5¾"
 CORD: 10' White

Greensboro Collection *New!*

GR900-OB/AB
Cover plate provided for standard junction box when necessary.



↑ **GR901-AB**
FINISH: Antique Brass
HEIGHT: 13"
PROJECTION: Extends 11 1/4"
BACKPLATE: 5 1/4" Diameter
BULB: 75W Type A
SWITCH: In-line
SHADE: Off White Linen Hardback
6" x 9" x 7"
CORD: 10' White



→ **GR901-OB**
FINISH: Oil Rubbed Bronze
HEIGHT: 13"
PROJECTION: Extends 11 1/4"
BACKPLATE: 5 1/4" Diameter
BULB: 75W Type A
SWITCH: In-line
SHADE: Off White Linen Hardback
6" x 9" x 7"
CORD: 10' White



← **GR900-OB**
FINISH: Oil Rubbed Bronze
HEIGHT: 11"
ARM: Extends 8 3/4"
BACKPLATE: 3 1/4" x 5"
BULB: 60W B10
SWITCH: In-line
SHADE: Off White Linen Hardback
4" x 7 1/4" x 6"
CORD: 10' White



→ **GR900-AB**
FINISH: Antique Brass
HEIGHT: 11"
PROJECTION: Extends 8 3/4"
BACKPLATE: 3 1/4" x 5"
BULB: 60W B10
SWITCH: In-line
SHADE: Off White Linen Hardback
4" x 7 1/4" x 6"
CORD: 10' White



→ **GR902-AB**
FINISH: Antique Brass
HEIGHT: 12"
PROJECTION: Extends 9 1/2"
BACKPLATE: 2" x 4"
BULB: 75W Type A
SWITCH: In-line
SHADE: Off White Linen Hardback
5" x 8" X 7"
CORD: 10' White



→ **GR902-OB**
FINISH: Oil Rubbed Bronze
HEIGHT: 12"
PROJECTION: Extends 9 1/2"
BACKPLATE: 2" x 4"
BULB: 75W Type A
SWITCH: In-line
SHADE: Off White Linen Hardback
5" x 8" X 7"
CORD: 10' White

GR901-GR902 lamps are pin-up only

High Ball Collection

FLOOR/TABLE/WALL LAMPS



← **HBC-101-BP**

FINISH: Chrome with Black
 HEIGHT: 57"
 BASE: 10¼"
 BULB: One 100W Type A
 SWITCH: On Socket
 SHADE: Black Parchment
 6" x 10" x 9"
 CORD: 10' Black



HBC-101-GS
 with optional Gray Silk Hardback



↑ **HBC-100**

FINISH: Chrome with Black
 HEIGHT: 62¼"
 BASE: 10¼"
 BULB: Two 100W Type A
 SWITCH: Pull Chain On Socket
 SHADE: Gray Silk Hardback
 17" x 18" x 10"
 CORD: 10' Black

→ **HBC-150**

FINISH: Chrome with Black
 HEIGHT: 30"
 BASE: 7½" Round
 BULB: Two 75W Type A
 SWITCH: Pull Chain On Socket
 SHADE: Gray Silk Hardback
 12" x 13" x 8"
 CORD: 10' Black



Home/Office Collection



→ **WS12-91-F**

FINISH: Oil Rubbed Bronze
 HEIGHT: 5"
 ARM: Extends 16"
 BACKPLATE: 5" Round
 BULB: One 60T10
 SWITCH: On-off On Socket
 SHADE: 10" x 2"
 CORD: 10' Ivory, 30" cord cover

← **WS12-71-F**

FINISH: Antique Brass
 HEIGHT: 5"
 ARM: Extends 16"
 BACKPLATE: 5" Round
 BULB: One 60T10
 SWITCH: On-off On Socket
 SHADE: 10" x 2"
 CORD: 10' Ivory, 30" cord cover

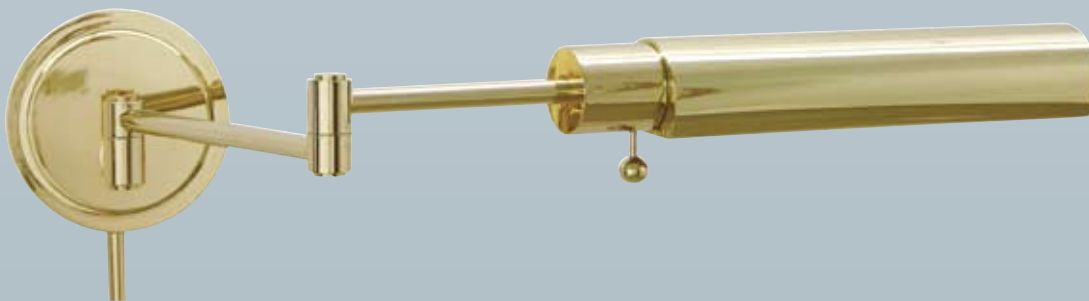

← **WS12-61-F**

FINISH: Polished Brass
 HEIGHT: 5"
 ARM: Extends 16"
 BACKPLATE: 5" Round
 BULB: One 60T10
 SWITCH: On-off On Socket
 SHADE: 10" x 2"
 CORD: 10' Ivory, 30" cord cover

→ **WS12-52-F**

FINISH: Satin Nickel
 HEIGHT: 5"
 ARM: Extends 16"
 BACKPLATE: 5" Round
 BULB: One 60T10
 SWITCH: On-off On Socket
 SHADE: 10" x 2"
 CORD: 10' Ivory, 30" cord cover



← **WS12-51-F**

FINISH: Satin Brass
 HEIGHT: 5"
 ARM: Extends 16"
 BACKPLATE: 5" Round
 BULB: One 60T10
 SWITCH: On-off On Socket
 SHADE: 10" x 2"
 CORD: 10' Ivory, 30" cord cover

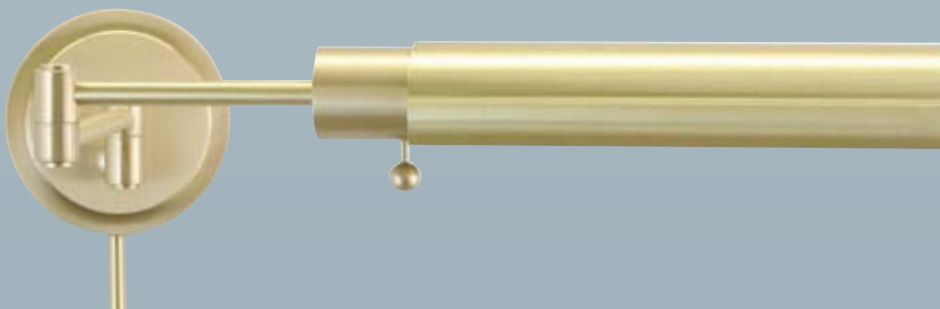

➔ **WS12-51-J**

FINISH: Satin Brass
 HEIGHT: 5"
 ARM: Extends 16"
 BACKPLATE: 5" Round
 BULB: One 100W Type A
 SWITCH: On-off On Socket
 SHADE: 8¾" x 3¾"
 CORD: 10' ivory, 30" cord cover



← **WS12-71-J**

FINISH: Antique Brass
 HEIGHT: 5"
 ARM: Extends 16"
 BACKPLATE: 5" Round
 BULB: One 100W Type A
 SWITCH: On-off On Socket
 SHADE: 8¾" x 3¾"
 CORD: 10' ivory, 30" cord cover

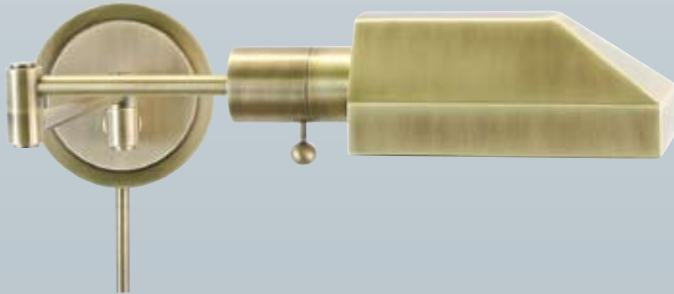

"See Better, Feel Better"

The products on this page can accept a natural, full spectrum, glare-free compact fluorescent bulb from **BULBRITE**.

↑ **WS12-91-J**

FINISH: Oil Rubbed Bronze
 HEIGHT: 5"
 ARM: Extends 16"
 BACKPLATE: 5" Round
 BULB: One 100W Type A
 SWITCH: On-off On Socket
 SHADE: 8¾" x 3¾"
 CORD: 10' ivory, 30" cord cover



↑ **WS12-61-J**

FINISH: Polished Brass
 HEIGHT: 5"
 ARM: Extends 16"
 BACKPLATE: 5" Round
 BULB: One 100W Type A
 SWITCH: On-off On Socket
 SHADE: 8¾" x 3¾"
 CORD: 10' ivory, 30" cord cover



↑ **WS12-52-J**

FINISH: Satin Nickel
 HEIGHT: 5"
 ARM: Extends 16"
 BACKPLATE: 5" Round
 BULB: One 100W Type A
 SWITCH: On-off On Socket
 SHADE: 8¾" x 3¾"
 CORD: 10' ivory, 30" cord cover



Home/Office Collection



← **WS14-91**

FINISH: Oil Rubbed Bronze
 HEIGHT: 12 ½"
 ARM: Extends 19"
 BACKPLATE: 5" Round
 BULB: One 100W 3-way
 SWITCH: On Socket
 SHADE: Off-white
 Linen Hardback
 6 ½" x 12" x 7"
 Attaches with acrylic diffuser
 CORD: 10' Ivory, 30" cord cover



↑ **WS14-51**

FINISH: Satin Brass
 HEIGHT: 12 ½"
 ARM: Extends 19"
 BACKPLATE: 5" Round
 BULB: One 100W 3-way
 SWITCH: On Socket
 SHADE: Off-white Linen Hardback
 6 ½" x 12" x 7"
 Attaches with acrylic diffuser
 CORD: 10' Ivory, 30" cord cover



← **WS14-52**

FINISH: Satin Nickel
 HEIGHT: 12 ½"
 ARM: Extends 19"
 BACKPLATE: 5" Round
 BULB: One 100W 3-way
 SWITCH: On Socket
 SHADE: White Linen Hardback
 6 ½" x 12" x 7"
 Attaches with acrylic diffuser
 CORD: 10' ivory, 30" cord cover

WALL SWING LAMPS



← WS14-71

FINISH: Antique Brass
HEIGHT: 12 ½"
ARM: Extends 19"
BACKPLATE: 5" Round
BULB: One 100W 3-way
SWITCH: On Socket
SHADE: Off-white Linen Hardback
 6 ½" x 12" x 7"
 Attaches with acrylic diffuser
CORD: 10' Ivory, 30" cord cover



↑ WS14-61

FINISH: Polished Brass
HEIGHT: 12 ½"
ARM: Extends 19"
BACKPLATE: 5" Round
BULB: One 100W 3-way
SWITCH: On Socket
SHADE: Off-white Linen Hardback
 6 ½" x 12" x 7"
 Attaches with acrylic diffuser
CORD: 10' Ivory, 30" cord cover



← WS14-9

FINISH: White
HEIGHT: 12 ½"
ARM: Extends 19"
BACKPLATE: 5" Round
BULB: One 100W 3-way
SWITCH: On Socket
SHADE: White Linen Hardback
 6 ½" x 12" x 7"
 Attaches with acrylic diffuser
CORD: 10' White, 30" cord cover

Home/Office Collection

DOUBLE WALL SWINGS



← **WS14-2-52**

FINISH: Satin Nickel
HEIGHT: 11"
ARM: Extends 19"
BACKPLATE: 18" x 4 1/8" x 5/8"
BULB: Two 100W 3-way
SWITCH: On Socket
SHADE: White Linen Hardback
Attaches with acrylic diffuser
6 1/2" x 12" x 7"
CORD: 11' Ivory, 30" cord cover



↓ **WS14-2-71**

FINISH: Antique Brass
HEIGHT: 11"
ARM: Extends 19"
BACKPLATE: 18" x 4 1/8" x 5/8"
BULB: Two 100W 3-way
SWITCH: On Socket
SHADE: Off-white Linen Hardback
Attaches with acrylic diffuser
6 1/2" x 12" x 7"
CORD: 11' Ivory, 30" cord cover

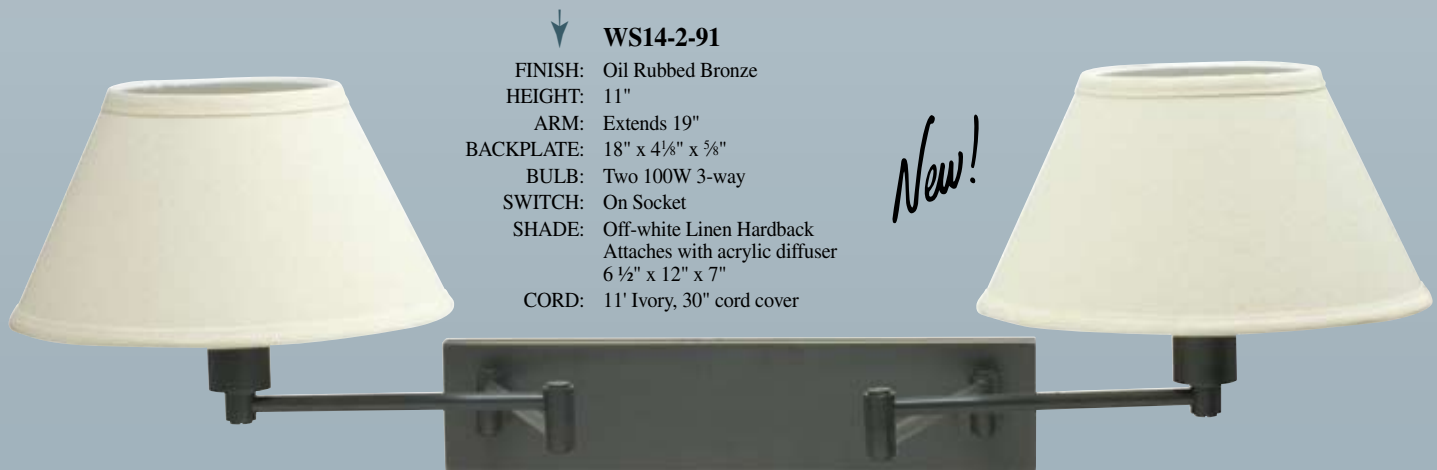

↓ **WS14-2-91**

FINISH: Oil Rubbed Bronze
HEIGHT: 11"
ARM: Extends 19"
BACKPLATE: 18" x 4 1/8" x 5/8"
BULB: Two 100W 3-way
SWITCH: On Socket
SHADE: Off-white Linen Hardback
Attaches with acrylic diffuser
6 1/2" x 12" x 7"
CORD: 11' Ivory, 30" cord cover

New!

SWING ARM LAMPS



← D435-91-J

FINISH: Oil Rubbed Bronze
 HEIGHT: 13 1/2" column
 BASE: 7 1/2" Round
 BULB: One 100W Type A
 SWITCH: On-off On Socket
 SHADE: 8 1/8" x 3 3/4"
 CORD: 9' Brown

"See Better, Feel Better"®

The J Shade on this page can accept a natural, full spectrum, glare-free compact fluorescent bulb from **BULBRITE**



→ D435-51-J

FINISH: Satin Brass
 HEIGHT: 13 1/2" column
 BASE: 7 1/2" Round
 BULB: One 100W Type A
 SWITCH: On-off On Socket
 SHADE: 8 1/8" x 3 3/4"
 CORD: 9' Brown



↑ D435-51-F

FINISH: Satin Brass
 HEIGHT: 13 1/2" column
 BASE: 7 1/2" round
 BULB: One 60T-10
 SWITCH: On-off On Socket
 SHADE: 10"
 CORD: 9' Brown



↑ D435-91-F

FINISH: Oil Rubbed Bronze
 HEIGHT: 13 1/2" column
 BASE: 7 1/2" round
 BULB: One 60T-10
 SWITCH: On-off On Socket
 SHADE: 10"
 CORD: 9' Brown

Home/Office Collection



↑ D436-71

FINISH: Antique Brass
 HEIGHT: 23 1/2"
 BASE: 7 1/2" Round
 BULB: One 100W 3-way
 SWITCH: On Socket
 SHADE: Off-white Linen hardback
 6 1/2" x 12" x 7"
 Attaches with acrylic diffuser
 CORD: 9' Brown



→ D436-52

FINISH: Satin Nickel
 HEIGHT: 23 1/2"
 BASE: 7 1/2" Round
 BULB: One 100W 3-way
 SWITCH: On Socket
 SHADE: White Linen hardback
 6 1/2" x 12" x 7"
 Attaches with acrylic diffuser
 CORD: 9' Clear



← D436-91

FINISH: Oil Rubbed Bronze
 HEIGHT: 23 1/2"
 BASE: 7 1/2" Round
 BULB: One 100W 3-way
 SWITCH: On Socket
 SHADE: Off-white Linen hardback
 6 1/2" x 12" x 7"
 Attaches with acrylic diffuser
 CORD: 9' Brown

FLOOR/TABLE SWING ARM LAMPS



← **PH100-91-F**

FINISH: Oil Rubbed Bronze
 HEIGHT: Adjusts 34" to 48"
 BASE: 10 1/2" Round
 BULB: One 60T-10
 SWITCH: On-off On Socket
 SHADE: 10" x 2"
 CORD: 10' Brown



← **PH100-61 -F**

FINISH: Polished Brass
 HEIGHT: Adjusts 34" to 48"
 BASE: 10 1/2" Round
 BULB: One 60T-10
 SWITCH: On-off On Socket
 SHADE: 10" x 2"
 CORD: 10' Brown



→ **PH100-51-F**

FINISH: Satin Brass
 HEIGHT: Adjusts 34" to 48"
 BASE: 10 1/2" Round
 BULB: One 60T-10
 SWITCH: On-off On Socket
 SHADE: 10" x 2"
 CORD: 10' Brown

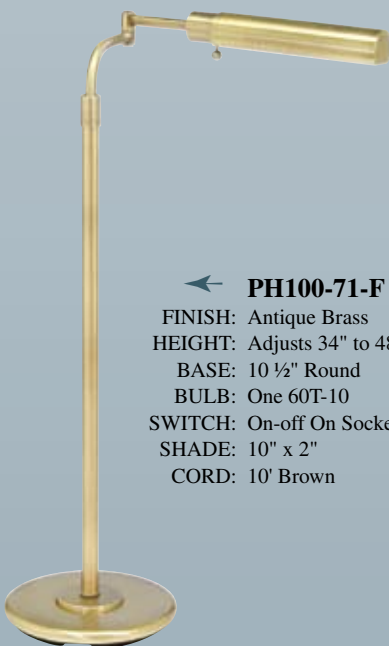

← **PH100-71-F**

FINISH: Antique Brass
 HEIGHT: Adjusts 34" to 48"
 BASE: 10 1/2" Round
 BULB: One 60T-10
 SWITCH: On-off On Socket
 SHADE: 10" x 2"
 CORD: 10' Brown



← **PH100-62-F**

FINISH: Chrome
 HEIGHT: Adjusts 34" to 48"
 BASE: 10 1/2" Round
 BULB: One 60T-10
 SWITCH: On-off On Socket
 SHADE: 10" x 2"
 CORD: 10' Clear



← **PH100-52-F**

FINISH: Satin Nickel
 HEIGHT: Adjusts 34" to 48"
 BASE: 10 1/2" Round
 BULB: One 60T-10
 SWITCH: On-off On Socket
 SHADE: 10" x 2"
 CORD: 10' Clear

Home/Office Collection



➔ **PH100-52-J**

FINISH: Satin Nickel
 HEIGHT: Adjusts 34" to 48"
 BASE: 10½" Round
 BULB: One 100W Type A
 SWITCH: On-off On Socket
 SHADE: 8 ⅛" x 3¾"
 CORD: 10' Clear



← **PH100-51-J**

FINISH: Satin Brass
 HEIGHT: Adjusts 34" to 48"
 BASE: 10½" Round
 BULB: One 100W Type A
 SWITCH: On-off On Socket
 SHADE: 8 ⅛" x 3¾"
 CORD: 10' Brown



↑ **PH100-71-J**

FINISH: Antique Brass
 HEIGHT: Adjusts 34" to 48"
 BASE: 10½" Round
 BULB: One 100W Type A
 SWITCH: On-off On Socket
 SHADE: 8 ⅛" x 3¾"
 CORD: 10' Brown



➔ **PH100-61-J**

FINISH: Polished Brass
 HEIGHT: Adjusts 34" to 48"
 BASE: 10½" Round
 BULB: One 100W Type A
 SWITCH: On-off On Socket
 SHADE: 8 ⅛" x 3¾"
 CORD: 10' Brown

↑ **PH100-91-J**
 FINISH: Oil Rubbed Bronze
 HEIGHT: Adjusts 34" to 48"
 BASE: 10½" Round
 BULB: One 100W Type A
 SWITCH: On-off On Socket
 SHADE: 8 ⅛" x 3¾"
 CORD: 10' Brown

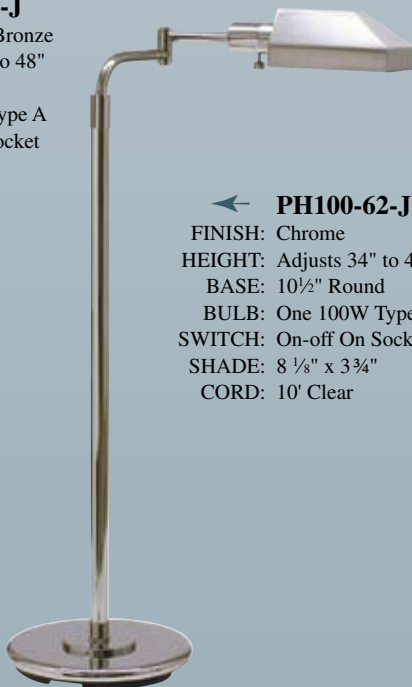

← **PH100-62-J**

FINISH: Chrome
 HEIGHT: Adjusts 34" to 48"
 BASE: 10½" Round
 BULB: One 100W Type A
 SWITCH: On-off On Socket
 SHADE: 8 ⅛" x 3¾"
 CORD: 10' Clear

"See Better, Feel Better"®

The products on this page can accept a natural, full spectrum, glare-free compact fluorescent bulb from **BULBRITE**

FLOOR SWING ARM LAMPS



← **PH101-52**

FINISH: Satin Nickel
HEIGHT: Adjusts from 37" to 51"
BASE: 10 1/2" Round
BULB: One 100W 3-way
SWITCH: On Socket
SHADE: White Linen Hardback
4 1/2" x 14" x 7"
Attaches with
Acrylic Diffuser
CORD: 10' Clear



← **PH101-51**

FINISH: Satin Brass
HEIGHT: Adjusts from 37" to 51"
BASE: 10 1/2" Round
BULB: One 100W 3-way
SWITCH: On Socket
SHADE: Off-white Linen Hardback
4 1/2" x 14" x 7"
Attaches with
Acrylic Diffuser
CORD: 10' Brown

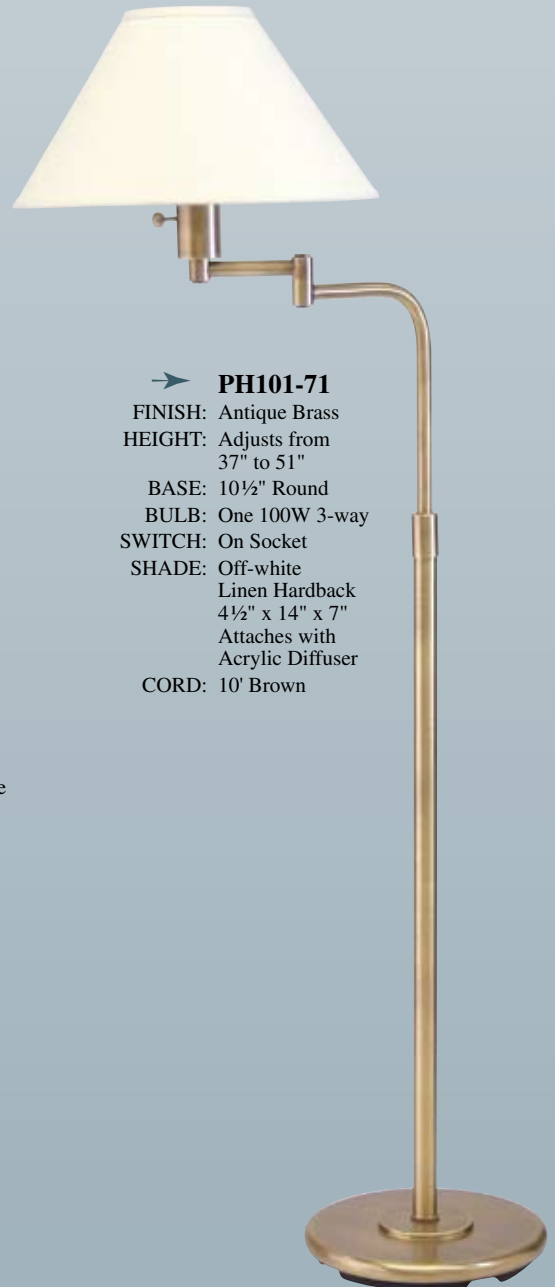

→ **PH101-71**

FINISH: Antique Brass
HEIGHT: Adjusts from
37" to 51"
BASE: 10 1/2" Round
BULB: One 100W 3-way
SWITCH: On Socket
SHADE: Off-white
Linen Hardback
4 1/2" x 14" x 7"
Attaches with
Acrylic Diffuser
CORD: 10' Brown



← **PH101-91**

FINISH: Oil Rubbed Bronze
HEIGHT: Adjusts from
37" to 51"
BASE: 10 1/2" Round
BULB: One 100W 3-way
SWITCH: On Socket
SHADE: Off-white
Linen Hardback
4 1/2" x 14" x 7"
Attaches with
Acrylic Diffuser
CORD: 10' Brown

Hyde Park Collection

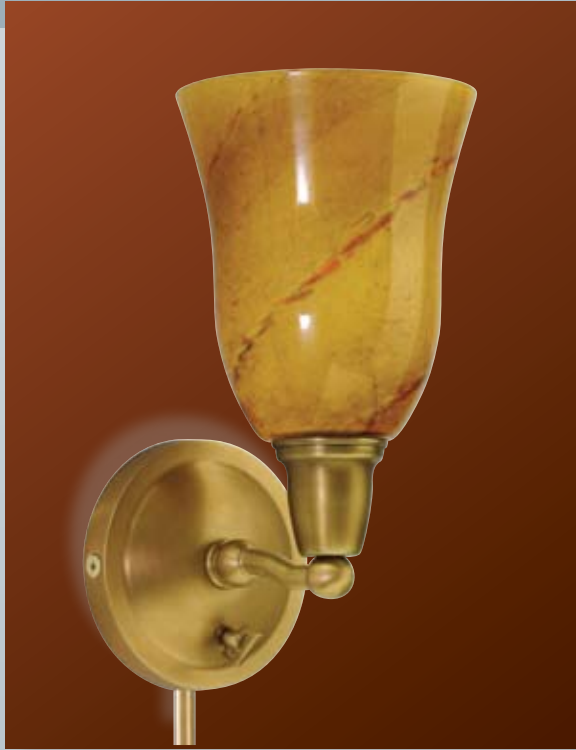

↑ **HP775-WB-AG**

FINISH: Weathered Brass
 HEIGHT: 11"
 BACKPLATE: 5" Round
 BULB: One 60 W Type A
 SWITCH: Full Range Dimmer on Backplate
 SHADE: Art Glass
 5 3/4" x 6 3/4"
 CORD: 10' Ivory, 30" cord cover



← **HP775-OB-OG**

FINISH: Oil Rubbed Bronze
 HEIGHT: 11"
 BACKPLATE: 5" Round
 BULB: One 60 W Type A
 SWITCH: Full Range Dimmer on Backplate
 SHADE: Opal Glass 5 3/4" x 6 3/4"
 CORD: 10' Ivory, 30" cord cover



→ **HP775-WB-OG**

FINISH: Weathered Brass
 HEIGHT: 11"
 BACKPLATE: 5" Round
 BULB: One 60 W Type A
 SWITCH: Full Range Dimmer on Backplate
 SHADE: Opal Glass
 5 3/4" x 6 3/4"
 CORD: 10' Ivory, 30" cord cover



→ **HP775-OB-AG**

FINISH: Oil Rubbed Bronze
 HEIGHT: 11"
 BACKPLATE: 5" Round
 BULB: One 60 W Type A
 SWITCH: Full Range Dimmer on Backplate
 SHADE: Art Glass
 5 3/4" x 6 3/4"
 CORD: 10' Ivory, 30" cord cover

WALL SCONCES/SWING ARM LAMPS



HP725-OB-AG

FINISH: Oil Rubbed Bronze
 HEIGHT: 10"
 ARM: 14"
 BACKPLATE: 5" Round
 BULB: One 60 W Type A
 SWITCH: Full-range Dimmer on Backplate
 SHADE: Art Glass 2¾" x 5½" x 7"
 CORD: 10' Ivory, 30" cord cover



HP725-OB-MSOB

FINISH: Oil Rubbed Bronze
 HEIGHT: 10"
 ARM: 14"
 BACKPLATE: 5" Round
 BULB: One 100 W Type A
 SWITCH: Full-range Dimmer on Backplate
 SHADE: Metal 5" x 7½" x 6¼"
 CORD: 10' Ivory, 30" cord cover



HP725-OB-BP

FINISH: Oil Rubbed Bronze
 HEIGHT: 10"
 ARM: 14"
 BACKPLATE: 5" Round
 BULB: One 100 W Type A
 SWITCH: Full-range Dimmer on Backplate
 SHADE: Black Parchment 5" x 9" x 7"
 CORD: 10' Ivory, 30" cord cover



HP725-OB-WL

FINISH: Oil Rubbed Bronze
 HEIGHT: 10"
 ARM: 14"
 BACKPLATE: 5" Round
 BULB: One 100 W Type A
 SWITCH: Full-range Dimmer on Backplate
 SHADE: Off-white Linen Hardback
 5" x 9" x 7"
 CORD: 10' Ivory, 30" cord cover



Hyde Park Collection



↑ **HP725-WB-BP**

FINISH: Weathered Brass
 HEIGHT: 10"
 ARM: 14"
 BACKPLATE: 5" Round
 BULB: One 100 W Type A
 SWITCH: Full-range Dimmer on Backplate
 SHADE: Black Parchment 5" x 9" x 7"
 CORD: 10' ivory, 30" cord cover



↑ **HP725-WB-WL**

FINISH: Weathered Brass
 HEIGHT: 10"
 ARM: 14"
 BACKPLATE: 5" Round
 BULB: One 100 W Type A
 SWITCH: Full-range Dimmer on Backplate
 SHADE: Off-white Linen Hardback 5" x 9" x 7"
 CORD: 10' Ivory, 30" cord cover

↓ **HP725-WB-MSWB**

FINISH: Weathered Brass
 HEIGHT: 10"
 ARM: 14"
 BACKPLATE: 5" Round
 BULB: One 100 W Type A
 SWITCH: Full-range Dimmer on Backplate
 SHADE: Metal 5" x 7½" x 6¼"
 CORD: 10' Ivory, 30" cord cover



↑ **HP725-WB-AG**

FINISH: Weathered Brass
 HEIGHT: 10"
 ARM: 14"
 BACKPLATE: 5" Round
 BULB: One 60 W Type A
 SWITCH: Full-range Dimmer on Backplate
 SHADE: Art Glass 2¾" x 5½" x 7"
 CORD: 10' Ivory, 30" cord cover



← **HP750-OB-WL**

FINISH: Oil Rubbed Bronze
 HEIGHT: 26"
 BASE: 7" Round
 BULB: One 100 W Type A
 SWITCH: Full Range Dimmer on base
 SHADE: Off-white Linen Hardback
 5" x 9" x 7"
 CORD: 10' Brown



← **HP750-OB-MSOB**

FINISH: Oil Rubbed Bronze
 HEIGHT: 26"
 BASE: 7" Round
 BULB: One 100 W Type A
 SWITCH: Full Range Dimmer on base
 SHADE: Metal
 5" x 7½" x 6¼"
 CORD: 10' Brown



← **HP750-OB-AG**

FINISH: Oil Rubbed Bronze
 HEIGHT: 26"
 BASE: 7" Round
 BULB: One 60 W Type A
 SWITCH: Full Range Dimmer on base
 SHADE: Art Glass
 2¾" x 5½" x 7"
 CORD: 10' Brown



→ **HP750-OB-BP**

FINISH: Oil Rubbed Bronze
 HEIGHT: 26"
 BASE: 7" Round
 BULB: One 100 W Type A
 SWITCH: Full Range Dimmer on base
 SHADE: Black Parchment
 5" x 9" x 7"
 CORD: 10' Brown

Hyde Park Collection



↑ **HP750-WB-MSWB**

FINISH: Weathered Brass
 HEIGHT: 26"
 BASE: 7" Round
 BULB: One 100 W Type A
 SWITCH: Full Range Dimmer on base
 SHADE: Metal
 5" x 7½" x 6¼"
 CORD: 10' Brown



↑ **HP750-WB-BP**

FINISH: Weathered Brass
 HEIGHT: 26"
 BASE: 7" Round
 BULB: One 100 W Type A
 SWITCH: Full Range Dimmer on base
 SHADE: Black Parchment
 5" x 9" x 7"
 CORD: 10' Brown



← **HP750-WB-WL**

FINISH: Weathered Brass
 HEIGHT: 26"
 BASE: 7" Round
 BULB: One 100 W Type A
 SWITCH: Full Range Dimmer on base
 SHADE: Off-white
 Linen Hardback
 5" x 9" x 7"
 CORD: 10' Brown



→ **HP750-WB-AG**

FINISHS: Weathered Brass
 HEIGHT: 26"
 BASE: 7" Round
 BULB: One 60 W Type A
 SWITCH: Full Range Dimmer on base
 SHADE: Art Glass
 2¾" x 5½" x 7"
 CORD: 10' Brown

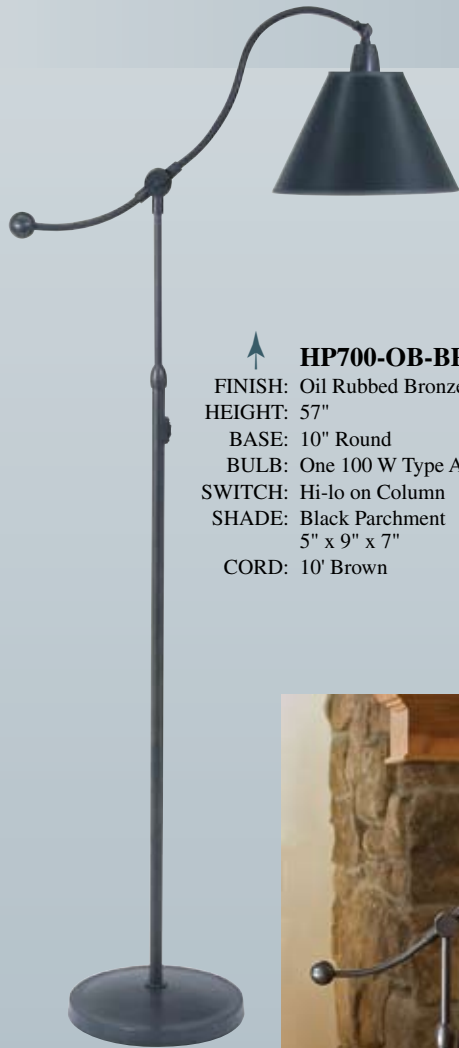

↑ **HP700-OB-BP**
 FINISH: Oil Rubbed Bronze
 HEIGHT: 57"
 BASE: 10" Round
 BULB: One 100 W Type A
 SWITCH: Hi-lo on Column
 SHADE: Black Parchment
 5" x 9" x 7"
 CORD: 10' Brown

→ **HP700-OB-MSOB**
 FINISH: Oil Rubbed Bronze
 HEIGHT: 57"
 BASE: 10" Round
 BULB: One 60 W Type A
 SWITCH: Hi-lo on Column
 SHADE: Metal
 5" x 7½" x 6¼"
 CORD: 10' Brown



→ **HP700-OB-WL**
 FINISH: Oil Rubbed Bronze
 HEIGHT: 57"
 BASE: 10" Round
 BULB: One 100 W Type A
 SWITCH: Hi-lo on Column
 SHADE: Off-white Linen
 Hardback 5" x 9" x 7"
 CORD: 10' Brown

↑ **HP700-OB-AG**
 FINISH: Oil Rubbed Bronze
 HEIGHT: 57"
 BASE: 10" Round
 BULB: One 60 W Type A
 SWITCH: Hi-lo on Column
 SHADE: Art Glass
 2¾" x 5½" x 7"
 CORD: 10' Brown

Hyde Park Collection



→ **HP700-WB-WL**

FINISH: Weathered Brass
HEIGHT: 57"
BASE: 10" Round
BULB: One 100 W Type A
SWITCH: Hi-lo on Column
SHADE: Off-white
Linen Hardback
5" x 9" x 7"
CORD: 10' Brown

↑ **HP700-WB-MSWB**

FINISH: Weathered Brass
HEIGHT: 57"
BASE: 10" Round
BULB: One 100 W Type A
SWITCH: Hi-lo on Column
SHADE: Metal
5" x 7½" x 6¼"
CORD: 10' Brown



→ **HP700-WB-AG**

FINISH: Weathered Brass
HEIGHT: 57"
BASE: 10" Round
BULB: One 60 W Type A
SWITCH: Hi-lo on Column
SHADE: Art glass
2¾" x 5½" x 7"
CORD: 10' Brown



← **HP700-WB-BP**

FINISH: Weathered Brass
HEIGHT: 57"
BASE: 10" Round
BULB: One 100 W Type A
SWITCH: Hi-lo on Column
SHADE: Black Parchment
5" x 9" x 7"
CORD: 10' Brown

➔ **PL16-OB**

FINISH: Oil Rubbed Bronze
 HEIGHT: 5"
 ARM: 11 1/2"
 BACKPLATE: 5" Diameter
 BULB: Two 60T10
 SWITCH: Full-range Dimmer on Backplate
 SHADE: 16"
 CORD: 10' ivory, 30" cord cover



← **PL16-WB**

FINISH: Weathered Brass
 HEIGHT: 5"
 ARM: 11 1/2"
 BACKPLATE: 5" Diameter
 BULB: Two 60T10
 SWITCH: Full-range Dimmer on Backplate
 SHADE: 16"
 CORD: 10' ivory, 30" cord cover



DL10 lamps are direct wire only



DL10-WB

FINISH: Weathered Brass
 HEIGHT: 2 3/4"
 ARM: 11 1/2"
 BACKPLATE: 2 3/4" x 4 1/2"
 BULB: One 60T10
 SWITCH: On Shade
 SHADE: 10"



DL10-OB

FINISH: Oil Rubbed Bronze
 HEIGHT: 2 3/4"
 ARM: 11 1/2"
 BACKPLATE: 2 3/4" x 4 1/2"
 BULB: One 60T10
 SWITCH: On Shade
 SHADE: 10"

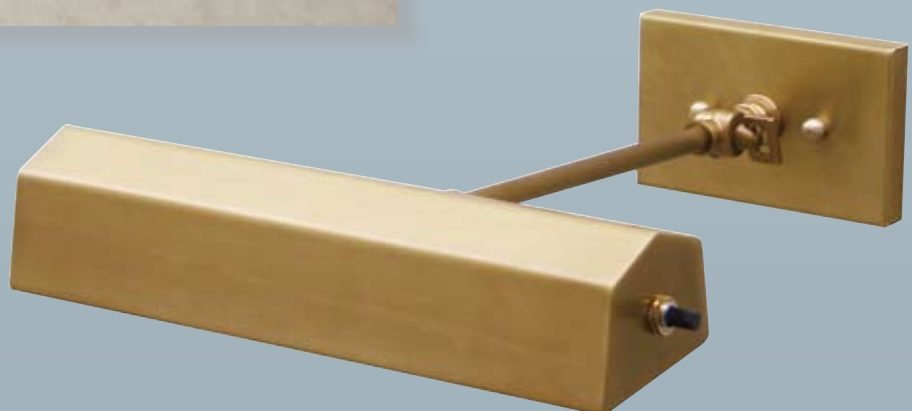

Library

➔ **PL20-WB**

FINISH: Weathered Brass
HEIGHT: Adjustable
ARM: Extends 16½"
BACKPLATE: 5" Round
BULB: One 100W Type A
SWITCH: Full Range Dimmer on Backplate
SHADE: 5" x 9" x 7" Black Parchment
CORD: 10' Ivory, 30" cord cover



← **PL20-OB**

FINISH: Oil Rubbed Bronze
HEIGHT: Adjustable
ARM: Extends 16½"
BACKPLATE: 5" Round
BULB: One 100W Type A
SWITCH: Full Range Dimmer on Backplate
SHADE: 5" x 9" x 7" Off-white Linen Hardback
CORD: 10' Ivory, 30" cord cover



▼ **DL20-WB**

FINISH: Weathered Brass
HEIGHT: Adjustable
ARM: Extends 16½"
BACKPLATE: 4½" x 4½" Square
BULB: One 100W Type A
SWITCH: Remote on Wall
SHADE: 5" x 9" x 7" Black Parchment



▲ **DL20-OB**

FINISH: Oil Rubbed Bronze
HEIGHT: Adjustable
ARM: Extends 16½"
BACKPLATE: 4½" x 4½" Square
BULB: One 100W Type A
SWITCH: Remote on Wall
SHADE: 5" x 9" x 7" Off-white Linen Hardback



New!



↑ **LL660-AB**
 FINISH: Antique Brass
 HEIGHT: 13"
 ARM: Extends 11 1/2"
 BACKPLATE: 1 3/4" x 3 1/2"
 Pin-up Only
 BULB: One 60W Medium Base
 SWITCH: On Socket
 SHADE: Off-white Softback
 5" x 10" x 6 3/4"
 CORD: 11' Ivory, 30" cord cover



➔ **LL660-OB**
 FINISH: Oil Rubbed Bronze
 HEIGHT: 13"
 ARM: Extends 11 1/2"
 BACKPLATE: 1 3/4" x 3 1/2"
 Pin-up Only
 BULB: One 60W Medium Base
 SWITCH: On Socket
 SHADE: Off-white Softback
 5" x 10" x 6 3/4"
 CORD: 11' Ivory, 30" cord cover

➔ **LL660-SN**
 FINISH: Satin Nickel
 HEIGHT: 13"
 ARM: Extends 11 1/2"
 BACKPLATE: 1 3/4" x 3 1/2"
 Pin-up Only
 BULB: One 60W Medium Base
 SWITCH: On Socket
 SHADE: White Softback
 5" x 10" x 6 3/4"
 CORD: 11' Ivory, 30" cord cover



← **LL660-PB**
 FINISH: Polished Brass
 HEIGHT: 13"
 ARM: Extends 11 1/2"
 BACKPLATE: 1 3/4" x 3 1/2"
 Pin-up Only
 BULB: One 60W Medium Base
 SWITCH: On Socket
 SHADE: Off-white Softback
 5" x 10" x 6 3/4"
 CORD: 11' Ivory, 30" cord cover



Library



← **LL662A-AB**
 FINISH: Antique Brass
 HEIGHT: 20"
 ARM: 6 1/8"
 BULB: 60B10 Candelabra
 SWITCH: In-line, 19" from arm exit
 SHADE: Off-white Softback
 4" x 9" x 5 1/2"
 CORD: 11' clear



New!

↑ **LL662A-OB**
 FINISH: Oil Rubbed Bronze
 HEIGHT: 20"
 ARM: 6 1/8"
 BULB: 60B10 Candelabra
 SWITCH: In-line, 19" from arm exit
 SHADE: Off-white Softback
 4" x 9" x 5 1/2"
 CORD: 11' clear



↑ **LL662A-SN**
 FINISH: Satin Nickel
 HEIGHT: 20"
 ARM: 6 1/8"
 BULB: 60B10 Candelabra
 SWITCH: In-line, 19" from arm exit
 SHADE: White Softback
 4" x 9" x 5 1/2"
 CORD: 11' clear



↑ **LL662A-PB**
 FINISH: Polished Brass
 HEIGHT: 20"
 ARM: 6 1/8"
 BULB: 60B10 Candelabra
 SWITCH: In-line, 19" from arm exit
 SHADE: Off-white Softback
 4" x 9" x 5 1/2"
 CORD: 11' clear

→ **LL663-SN**

FINISH: Satin Nickel
 HEIGHT: 20"
 ARM: 9 3/4"
 BULB: 60 Watt Medium Base
 SWITCH: On Socket
 SHADE: White Softback
 4" x 11" x 7 1/2"
 CORD: 11' clear



↑ **LL663-PB**

FINISH: Polished Brass
 HEIGHT: 20"
 ARM: 9 3/4"
 BULB: 60 Watt Medium Base
 SWITCH: On Socket
 SHADE: Off-white Softback
 4" x 11" x 7 1/2"
 CORD: 11' clear

→ **LL663-AB**

FINISH: Antique Brass
 HEIGHT: 20"
 ARM: 9 3/4"
 BULB: 60 Watt Medium Base
 SWITCH: On Socket
 SHADE: Off-white Softback
 4" x 11" x 7 1/2"
 CORD: 11' clear



Lincoln Collection



↑ **OL651-WB**

FINISH: Weathered Brass
HEIGHT: Adjusts from 8" to 22"
BASE: 6" Round
BULB: One 100W Type A
SWITCH: In-line, 6" from base
SHADE: 5" x 9" x 7"
Black Parchment
CORD: 10' Brown



← **OL651-OB**

FINISH: Oil Rubbed Bronze
HEIGHT: Adjusts from 8" to 22"
BASE: 6" Round
BULB: One 100W Type A
SWITCH: In-Line, 6" from base
SHADE: 5" x 9" x 7"
Off-white Linen Hardback
CORD: 10' Brown



← **OL650-OB**

FINISH: Oil Rubbed Bronze
HEIGHT: Adjusts from 8" to 22"
BASE: 6" Round
BULB: One 100W Type A
SWITCH: Socket
SHADE: 8.5" x 11.5" x 7.75"
Off-white
Linen Hardback
CORD: 10' Brown

→ **OL600-WB**

FINISH: Weathered Brass
 HEIGHT: Adjusts from 48" to 59"
 BASE: 10" Round
 BULB: One 150W 3-way
 SWITCH: On Socket
 SHADE: Black Parchment
 11" x 15" x 9"
 CORD: 10' Brown



→ **OL600-OB**

FINISH: Oil Rubbed Bronze
 HEIGHT: Adjusts from 48" to 59"
 BASE: 10" Round
 BULB: One 150W 3-way
 SWITCH: On Socket
 SHADE: Off-white Linen Hardback
 11" x 15" x 9"
 CORD: 10' Brown



↑ **OL650-WB**

FINISH: Weathered Brass
 HEIGHT: Adjusts from 8" to 22"
 BASE: 6" Round
 BULB: One 100W Type A
 SWITCH: Socket
 SHADE: 8.5" x 11.5" x 7.75"
 Black Parchment
 CORD: 10' Brown

Newport Collection



↑ **N-651-AB**
FINISH: Antique Brass
HEIGHT: 30 1/4"
BASE: 7 3/4" Round
BULBS: Two 60W Type A
SWITCH: Pull Chain
SHADE: Off-white softback
10" x 18" x 10 1/4"
CORD: 10' Brown



← **N-651-PTR**
FINISH: Pewter
HEIGHT: 30 1/4"
BASE: 7 3/4" Round
BULBS: Two 60W Type A
SWITCH: Pull Chain
SHADE: White Softback
10" x 18" x 10 1/4"
CORD: 10' Clear



↑ **N-651-OB**
FINISH: Oil Rubbed Bronze
HEIGHT: 30 1/4"
BASE: 7 3/4" Round
BULBS: Two 60W Type A
SWITCH: Pull Chain
SHADE: Off-white Softback
10" x 18" x 10 1/4"
CORD: 10' Brown

➔ **N-653-OB**

FINISH: Oil Rubbed Bronze
 HEIGHT: 30¼"
 BASE: 9" Round
 BULBS: One 100W 3-way
 SWITCH: On Socket
 SHADE: Off-white Softback
 10" x 18" x 10¼"
 CORD: 10' Brown



← **N-653-AB**

FINISH: Antique Brass
 HEIGHT: 30¼"
 BASE: 9" Round
 BULBS: One 100W 3-way
 SWITCH: On Socket
 SHADE: Off-white Softback
 10" x 18" x 10¼"
 CORD: 10' Brown

Newport Collection



New!



N-650-AB

FINISH: Antique Brass
 HEIGHT: 30 1/4"
 BASE: 9" Round
 BULBS: Standard Six Way
 One 150W 3-way
 Three 75W Type A
 SWITCH: On Column
 SHADE: Off-white Softback
 12" x 19" x 12"
 CORD: 10' Brown



New!

N-650-OB

FINISH: Oil Rubbed Bronze
 HEIGHT: 30 1/4"
 BASE: 9" Round
 BULBS: Standard Six Way
 One 150W 3-way
 Three 75W Type A
 SWITCH: On Column
 SHADE: Off-white Softback
 12" x 19" x 12"
 CORD: 10' Brown



N-652-OB

FINISH: Oil Rubbed Bronze
 HEIGHT: 30 3/4"
 BASE: 6" Round
 BULBS: One 100W 3-way
 SWITCH: On Socket
 SHADE: Off-white Softback
 7" x 15 3/4" x 11"
 CORD: 10' Brown



N-652-AB

FINISH: Antique Brass
 HEIGHT: 30 3/4"
 BASE: 6" Round
 BULBS: One 100W 3-way
 SWITCH: On Socket
 SHADE: Off-white Softback
 7" x 15 3/4" x 11"
 CORD: 10' Brown

FLOOR/TABLE LAMPS



↑ **N-600-OB**
 FINISH: Oil Rubbed Bronze
 HEIGHT: 74¾"
 BASE: 12" Round
 BULB: One 150W Type A
 SWITCH: Floor Dimmer
 SHADE: 9" x 11¾" Amber Glass
 CORD: 10' Brown



← **N-600-PTR**
 FINISH: Pewter
 HEIGHT: 74¾"
 BASE: 12" Round
 BULB: One 150 W Type A
 SWITCH: Floor Dimmer
 SHADE: 9" x 11¾" Opal Glass
 CORD: 10' Clear

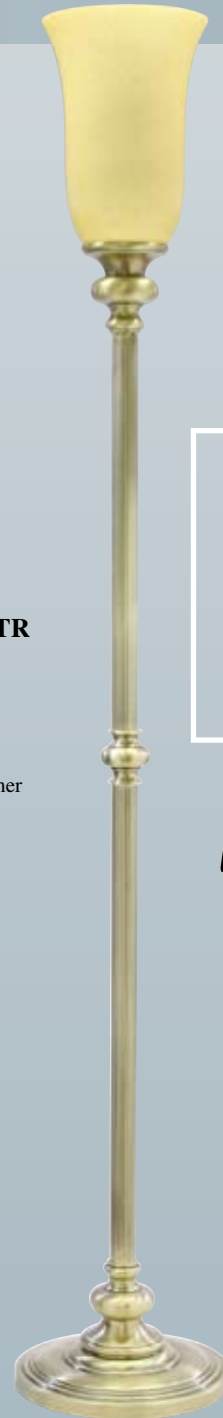

↑ **N-600-AB**
 FINISH: Antique Brass
 HEIGHT: 74¾"
 BASE: 12" Round
 BULB: One 150W Type A
 SWITCH: Floor Dimmer
 SHADE: 9" x 11¾" Amber Glass
 CORD: 10' Brown



New!

Shade Option for
N600-PTR-O
N600-OB-O
N600-AB-O
 SHADE: 15¾ X 6"
 Opal Glass

Newport Collection



↑ **N-601-OB**

FINISH: Oil Rubbed Bronze
 HEIGHT: 57 ½"
 BASE: 12" Round
 BULBS: Two 100W Type A
 SWITCH: Pull Chain
 SHADE: Off-white Softback
 12" x 19" x 12"
 CORD: 10' Brown



← **N-601-PTR**

FINISH: Pewter
 HEIGHT: 57 ½"
 BASE: 12" Round
 BULBS: Two 100W
 Type A
 SWITCH: Pull Chain
 SHADE: White Softback
 12" x 19" x 12"
 CORD: 10' Clear



↑ **N-601-AB**

FINISH: Antique Brass
 HEIGHT: 57 ½"
 BASE: 12" Round
 BULBS: Two 100W
 Type A
 SWITCH: Pull Chain
 SHADE: Off-white Softback
 12" x 19" x 12"
 CORD: 10' Brown



← **N-602-AB**

FINISH: Antique Brass
 HEIGHT: 55 ¾"
 BASE: 12" Round
 BULB: One 150W 3-way
 SWITCH: On Socket
 SHADE: Off-white Softback
 12" x 19" x 12"
 CORD: 10' Brown
 TABLE: 17" Diameter
 Table Height 24"



→ **N-602-PTR**

FINISH: Pewter
 HEIGHT: 55 ¾"
 BASE: 12" Round
 BULB: One 150W 3-way
 SWITCH: On Socket
 SHADE: White Softback
 12" x 19" x 12"
 CORD: 10' Clear
 TABLE: 17" Diameter
 Table Height 24"

← **N-602-OB**

FINISH: Oil Rubbed Bronze
 HEIGHT: 55 ¾"
 BASE: 12" Round
 BULB: One 150W 3-way
 SWITCH: On Socket
 SHADE: Off-white Softback
 12" x 19" x 12"
 CORD: 10' Brown
 TABLE: 17" Diameter
 Table Height 24"



Newport Collection



↑ **N-603-OB**
 FINISH: Oil Rubbed Bronze
 HEIGHT: 66½"
 BASE: 12" Round
 BULBS: Standard Six-way
 One 150W 3-way,
 Three 75W Single
 SWITCH: Top of Column
 SHADE: Off-white Softback
 12" x 19" x 12"
 CORD: 10' Brown



← **N-603-AB**
 FINISH: Antique Brass
 HEIGHT: 66½"
 BASE: 12" Round
 BULBS: Standard Six-way
 One 150W 3-way,
 Three 75W Single
 SWITCH: Top of Column
 SHADE: Off-white Softback
 12" x 19" x 12"
 CORD: 10' Brown

↑ **N-603-PTR**
 FINISH: Pewter
 HEIGHT: 66½"
 BASE: 12" Round
 BULBS: Standard Six-way
 One 150W 3-way,
 Three 75W Single
 SWITCH: Top of Column
 SHADE: White Softback
 12" x 19" x 12"
 CORD: 10' Clear



N-604-OB

FINISH: Oil Rubbed Bronze
 HEIGHT: 61"
 BASE: 12" Round
 BULB: One 150W 3-way
 SWITCH: On Socket
 SHADE: Off-white Softback
 10" x 18" x 10½"
 CORD: 10' Brown

→ **N-604-AB**
 FINISH: Antique Brass
 HEIGHT: 61"
 BASE: 12" Round
 BULB: One 150W 3-way
 SWITCH: On Socket
 SHADE: Off-white Softback
 10" x 18" x 10½"
 CORD: 10' Brown



→ **N-604-PTR**
 FINISH: Pewter
 HEIGHT: 61"
 BASE: 12" Round
 BULB: One 150W 3-way
 SWITCH: On Socket
 SHADE: White Softback
 10" x 18" x 10½"
 CORD: 10' Clear

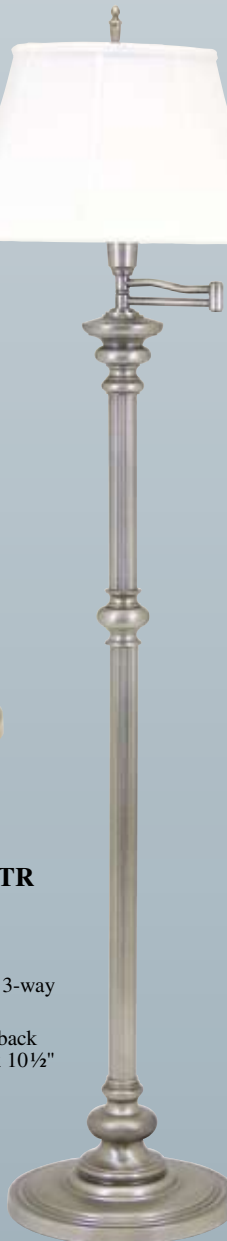

← **N606-AB**
 FINISH: Antique Brass
 HEIGHT: 63"
 BASE: 12"
 BULB: Standard Six-way
 One 150W 3-way
 Three 75W Single
 SWITCH: Top of Column
 SHADE: Off-white Softback
 14" x 21" x 12½"
 CORD: 10' Brown

→ **N606-OB**
 FINISH: Oil Rubbed Bronze
 HEIGHT: 63"
 BASE: 12"
 BULB: Standard Six-way
 One 150W 3-way
 Three 75W Single
 SWITCH: Top of Column
 SHADE: Off-white Softback
 14" x 21" x 12½"
 CORD: 10' Brown



Shelburne Collection



← **S340-MB**

FINISH: Mahogany Bronze, Black & Tan Marble
 HEIGHT: 21½"
 BASE: 5⅓" Square
 BULB: One 100W Type A
 SWITCH: On Socket
 SHADE: Off-white Softback 5½" x 12" x 8½"
 CORD: 10' Brown



→ **S341-MB**

FINISH: Mahogany Bronze, Black & Tan Marble
 HEIGHT: 32"
 BASE: 5⅓" Square
 BULB: One 100W Type A
 SWITCH: In-line, 6" from base
 SHADE: Off-white Softback 5½" x 12" x 8½"
 CORD: 10' Brown



← **S330-71**

FINISH: Antique Brass with Green Leather
 HEIGHT: 25¼"
 BASE: 5½" square
 BULB: One 100W 3-way
 SWITCH: On Socket
 SHADE: Off-white Linen with Brown trim 7" x 13" x 9½"
 CORD: 9' brown



→ **S330-52**

FINISH: Satin Nickel with Black Leather
 HEIGHT: 25¼"
 BASE: 5½" square
 BULB: One 100W 3-way
 SWITCH: On Socket
 SHADE: White Linen with Black trim 7" x 13" x 9½"
 CORD: 9' brown



← **DSK-430-MB**

FINISH: Oil Rubbed Bronze &
Black and Tan Marble
HEIGHT: 13 3/4"
BASE: 5" Square
BULB: 60T10
SWITCH: On base
SHADE: 9" Amber Glass
CORD: 9' Brown



← **DSK-428-G61**

FINISH: Polished Brass
HEIGHT: 13 3/4"
BASE: 5" Square
BULB: 60T10
SWITCH: On base
SHADE: 9" Green Glass
CORD: 9' Brown



→ **DSK-428-G71**

FINISH: Antique Brass
HEIGHT: 13 1/4"
BASE: 5" Square
BULB: 60T10
SWITCH: On base
SHADE: 9" Green Glass
CORD: 9' Brown

Vision

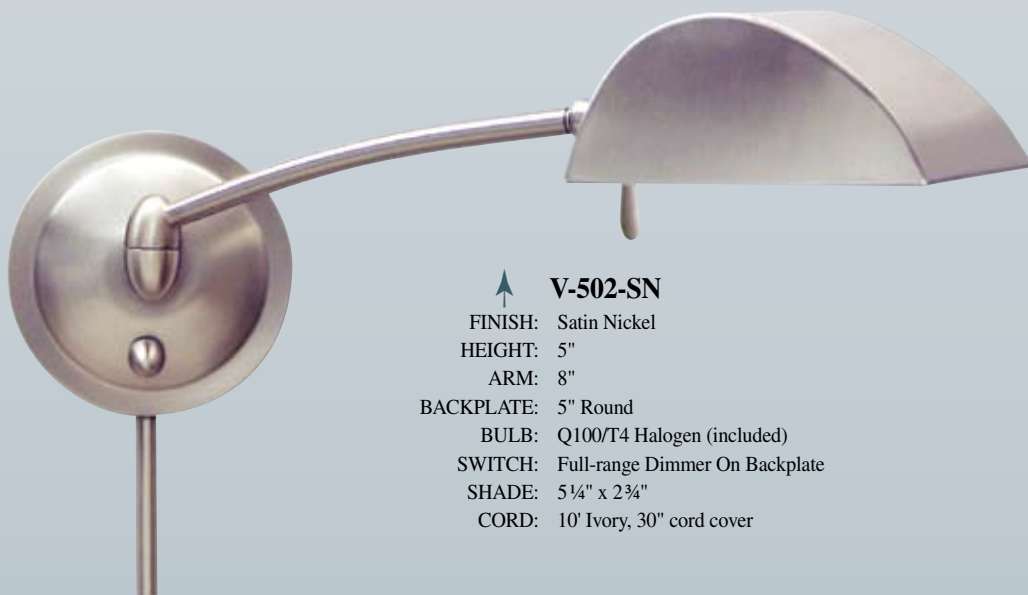

↑ **V-502-SN**

FINISH: Satin Nickel
HEIGHT: 5"
ARM: 8"
BACKPLATE: 5" Round
BULB: Q100/T4 Halogen (included)
SWITCH: Full-range Dimmer On Backplate
SHADE: 5¼" x 2¾"
CORD: 10' Ivory, 30" cord cover

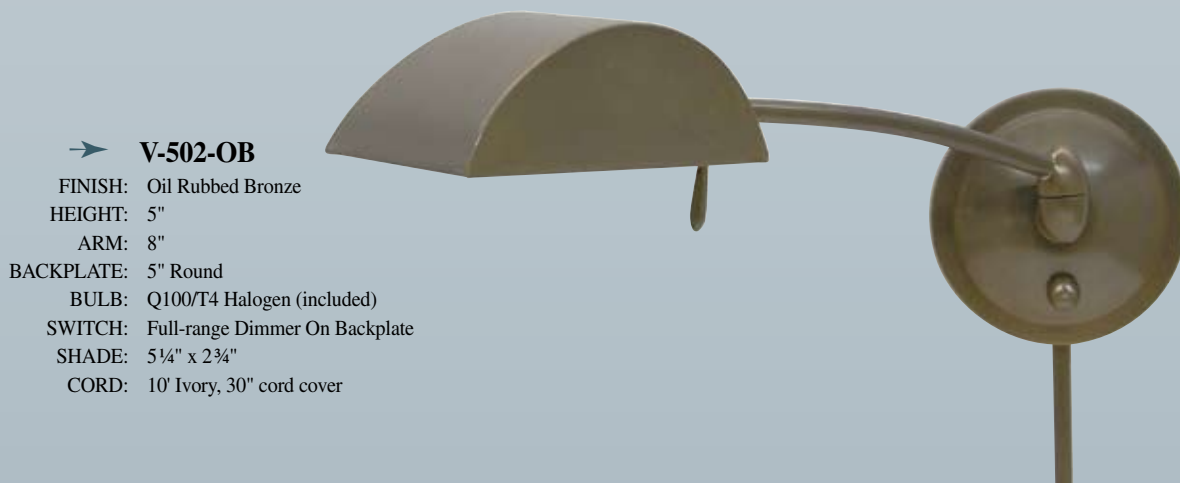

→ **V-502-OB**

FINISH: Oil Rubbed Bronze
HEIGHT: 5"
ARM: 8"
BACKPLATE: 5" Round
BULB: Q100/T4 Halogen (included)
SWITCH: Full-range Dimmer On Backplate
SHADE: 5¼" x 2¾"
CORD: 10' Ivory, 30" cord cover

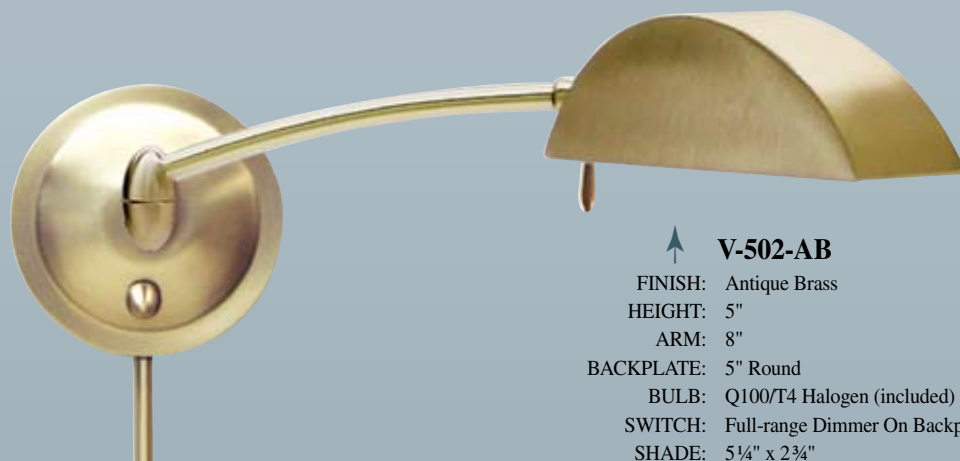

↑ **V-502-AB**

FINISH: Antique Brass
HEIGHT: 5"
ARM: 8"
BACKPLATE: 5" Round
BULB: Q100/T4 Halogen (included)
SWITCH: Full-range Dimmer On Backplate
SHADE: 5¼" x 2¾"
CORD: 10' Ivory, 30" cord cover

DESK/WALL SWING LAMPS



← **V-501-OB**

FINISH: Oil Rubbed Bronze
HEIGHT: 19"
BASE: 7" Round
BULB: Q100/T4 Halogen (included)
SWITCH: Full Range Dimmer on base
SHADE: 5¼" x 2¾"
CORD: 10' Brown



↑ **V-501-SN**

FINISH: Satin Nickel
HEIGHT: 19"
BASE: 7" Round
BULB: Q100/T4 Halogen (included)
SWITCH: Full Range Dimmer on base
SHADE: 5¼" x 2¾"
CORD: 10' Black

↑ **V-501-AB**

FINISH: Antique Brass
HEIGHT: 19"
BASE: 7" Round
BULB: Q100/T4 Halogen (included)
SWITCH: Full Range Dimmer on base
SHADE: 5¼" x 2¾"
CORD: 10' Brown

Vision



→ **V-503-AB**

FINISH: Antique Brass
HEIGHT: Adjusts 39" to 49"
BASE: 10" Round
BULB: Q100/T4
Halogen (included)
SWITCH: Hi-lo on Column
SHADE: 5¼" x 2¾"
CORD: 10' Brown

← **V-503-SN**

FINISH: Satin Nickel
HEIGHT: Adjusts 39" to 49"
BASE: 10" Round
BULB: Q100/T4
Halogen (included)
SWITCH: Hi-lo on Column
SHADE: 5¼" x 2¾"
CORD: 10' Clear

→ **V-503-OB**

FINISH: Oil Rubbed Bronze
HEIGHT: Adjusts 39" to 49"
BASE: 10" Round
BULB: Q100/T4
Halogen 1(included)
SWITCH: Hi-lo on Column
SHADE: 5¼" x 2¾"
CORD: 10' Brown

FLOOR SWING LAMPS



V500-2-SN

FINISH: Satin Nickel
 HEIGHT: Adjusts 39" to 56"
 BASE: 10" Round
 BULB: Q100/T4 Halogen (included)
 SWITCH: Hi-lo On Each Column
 SHADES: 5 1/4" x 2 3/4"
 CORD: 10' Clear



V500-2-OB

FINISH: Oil Rubbed Bronze
 HEIGHT: Adjusts 39" to 56"
 BASE: 10" Round
 BULB: Q100/T4 Halogen (included)
 SWITCH: Hi-lo On Each Column
 SHADES: 5 1/4" x 2 3/4"
 CORD: 10' Brown



V500-2-AB

FINISH: Antique Brass
 HEIGHT: Adjusts 39" to 56"
 BASE: 10" Round
 BULB: Q100/T4 Halogen (included)
 SWITCH: Hi-lo On Each Column
 SHADES: 5 1/4" x 2 3/4"
 CORD: 10' Brown



Glass Wall Sconces

ADA
COMPLIANT



← **WL601-AB**
FINISH: Antique Brass
HEIGHT: 10 ¼"
BACKPLATE: 2 ¾" x 4 ¾"
BULB: One 60T10
SHADE: White Glass
7 ¾" x 1 ⅞"



→ **WL601-PC**
FINISH: Polished Chrome
HEIGHT: 10 ¼"
BACKPLATE: 2 ¾" x 4 ¾"
BULB: One 60T10
SHADE: White Glass
7 ¾" x 1 ⅞"



← **WL601-OB**
FINISH: Oil Rubbed Bronze
HEIGHT: 10 ¼"
BACKPLATE: 2 ¾" x 4 ¾"
BULB: One 60T10
SHADE: Amber Glass
7 ¾" x 1 ⅞"



← **WL601-PB**
FINISH: Polished Brass
HEIGHT: 10 ¼"
BACKPLATE: 2 ¾" x 4 ¾"
BULB: One 60T10
SHADE: White Glass
7 ¾" x 1 ⅞"



↓ **WL601-SN**
FINISH: Satin Nickel
HEIGHT: 10 ¼"
BACKPLATE: 2 ¾" x 4 ¾"
BULB: One 60T10
SHADE: White Glass 7 ¾" x 1 ⅞"

Cover plate provided for
standard junction box
when necessary.



↑ **WL602-AB**
FINISH: Antique Brass
HEIGHT: 13"
BACKPLATE: 2 7/8" x 12 1/2"
BULB: One 60T10
SHADE: White Glass,
7 3/4" x 1 7/8"

→ **WL602-SN**
FINISH: Satin Nickel
HEIGHT: 13"
BACKPLATE: 2 7/8" x 12 1/2"
BULB: One 60T10
SHADE: White Glass,
7 3/4" x 1 7/8"



Cover plate provided for standard junction box when necessary.

Glass Wall Sconces



← **WL604-SB**

FINISH: Satin Brass
 HEIGHT: 11 3/8"
 BACKPLATE: 2 1/2" x 5 3/4"
 BULB: One 60B10 candelabra
 SHADE: White Glass,
 4 1/4" x 1 7/8" x 3 3/4"



→ **WL604-SN**

FINISH: Satin Nickel
 HEIGHT: 11 3/8"
 BACKPLATE: 2 1/2" x 5 3/4"
 BULB: One 60B10 candelabra
 SHADE: White Glass
 4 1/4" x 1 7/8" x 3 3/4"

Cover plate provided for
 standard junction box
 when necessary.



← **WL615-SN**

FINISH: Satin Nickel
 HEIGHT: 10 1/4"
 BACKPLATE: 3 1/2" x 5 3/4"
 BULB: One 60G16 1/2
 candelabra
 SHADE: White Glass
 4" x 1 3/4" x 5"



→ **WL615-OB**

FINISH: Oil Rubbed Bronze
 HEIGHT: 10 1/4"
 BACKPLATE: 3 1/2" x 5 3/4"
 BULB: One 60G16 1/2 candelabra
 SHADE: Amber Glass, 4" x 1 3/4" x 5"

GLASS WALL SCONCES



→ **WL612-SN**

FINISH: Satin Nickel
 HEIGHT: 8 1/2"
 BACKPLATE: 2 7/8" x 5 7/8"
 BULB: One 60G16 1/2
 candelabra
 SHADE: White Glass
 3 1/2" x 3 3/4" x 1 1/2"



↑ **WL612-OB**

FINISH: Oil Rubbed Bronze
 HEIGHT: 8 1/2"
 BACKPLATE: 2 7/8" x 5 7/8"
 BULB: One 60G16 1/2 candelabra
 SHADE: Amber Glass,
 3 1/2" x 3 3/4" x 1 1/2"

← **WL612-AB**

FINISH: Antique Brass
 HEIGHT: 8 1/2"
 BACKPLATE: 2 7/8" x 5 7/8"
 BULB: One 60G16 1/2
 candelabra
 SHADE: White Glass
 3 1/2" x 3 3/4" x 1 1/2"



Cover plate provided for standard junction box when necessary.

Glass Wall Sconces



WL650-AS

FINISH: Antique Silver
HEIGHT: 12"
BACKPLATE: 5" x 6"
BULB: One 60W Type A
SHADE: White Glass
5 1/4" x 5"



WL650-OB

FINISH: Oil Rubbed Bronze
HEIGHT: 12"
BACKPLATE: 5" x 6"
BULB: One 60W Type A
SHADE: White Glass
5 1/4" x 5"



WL650-AB

FINISH: Antique Brass
HEIGHT: 12"
BACKPLATE: 5" x 6"
BULB: One 60W Type A
SHADE: White Glass
5 1/4" x 5"

GLASS WALL SCONCES



WL651-AB

FINISH: Antique Brass
 HEIGHT: 11"
 BACKPLATE: 6" x 6"
 BULB: One 60W Type A
 SHADE: White Glass
 5 1/2" x 5 1/4"



WL651-AS

FINISH: Antique Silver
 HEIGHT: 11"
 BACKPLATE: 6" x 6"
 BULB: One 60W Type A
 SHADE: White Glass
 5 1/2" x 5"



WL651-OB

FINISH: Oil Rubbed Bronze
 HEIGHT: 11"
 BACKPLATE: 6" x 6"
 BULB: One 60W Type A
 SHADE: White Glass
 5 1/2" x 5 1/4"



WL652-OB

FINISH: Oil Rubbed Bronze
 HEIGHT: 12"
 BACKPLATE: 4 3/4" x 4 3/4"
 BULB: One 60W Type A
 SHADE: White Glass
 5 1/4" x 5"



WL652-AS

FINISH: Antique Silver
 HEIGHT: 12"
 BACKPLATE: 4 3/4" x 4 3/4"
 BULB: One 60W Type A
 SHADE: White Glass
 5 1/4" x 5"



WL652-AB

FINISH: Antique Brass
 HEIGHT: 12"
 BACKPLATE: 4 3/4" x 4 3/4"
 BULB: One 60W Type A
 SHADE: White Glass
 5 1/4" x 5"



Wall Sconces

→ **WL609-SB**

FINISH: Satin Brass
 HEIGHT: 13 3/4"
 BACKPLATE: 2 1/4" x 4 1/2"
 BULB: One 60B10 candelabra
 SHADE: Off-white Softback
 4 1/8" x 7" x 5 3/4"



WL609: Cover plate provided for standard junction/switch box when necessary.



→ **WL620-CB**

FINISH: Copper Bronze
 HEIGHT: 12 1/4"
 BACKPLATE: 4 1/4" Round
 BULB: One 60B10 candelabra
 SHADE: Off-White Softback
 4" x 6 1/2" x 7"

→ **WL609-SN**

FINISH: Satin Nickel
 HEIGHT: 13 3/4"
 BACKPLATE: 2 1/4" x 4 1/2"
 BULB: One 60B10 candelabra
 SHADE: White Softback
 4 1/8" x 7" x 5 3/4"





↑ **WL616-PB**

FINISH: Polished Brass
 HEIGHT: 19"
 BACKPLATE: 4 1/8" square
 BULB: Two 60B10 candelabra
 SHADE: Off-White Softback
 7 1/4" x 9 1/4" x 4 1/2"



↑ **WL616-AB**

FINISH: Antique Brass
 HEIGHT: 19"
 BACKPLATE: 4 1/8" square
 BULB: Two 60B10 candelabra
 SHADE: Off-White Softback
 7 1/4" x 9 1/4" x 4 1/2"



← **WL616-CB**

FINISH: Copper Bronze
 HEIGHT: 19"
 BACKPLATE: 4 1/8" square
 BULB: Two 60B10 candelabra
 SHADE: Off-White Softback
 7 1/4" x 9 1/4" x 4 1/2"

Wall Swings



↑ **WS-704**

FINISH: Polished Brass
HEIGHT: 12"
ARM: Extends 19"
BACKPLATE: 6 ¼" x 3 ½"
BULB: One 100W Type A
SWITCH: Full Range Dimmer On Socket
SHADE: White Pleated Softback
 7" x 13 ½" x 7 ½"
CORD: 11' Ivory, 30" cord cover



↑ **WS-706**

FINISH: Polished Brass
HEIGHT: 16 ½"
ARM: Extends 19"
BACKPLATE: 6 ¼" x 3 ½"
BULB: One 100W 3-way
SWITCH: On Socket
SHADE: Off-white Softback
 5 ½" x 12" x 8 ½"
CORD: 11' Ivory,
 30" cord cover



← **WS-706-AB**

FINISH: Antique Brass
HEIGHT: 16 ½"
ARM: Extends 19"
BACKPLATE: 6 ¼" x 3 ½"
BULB: One 100W 3-way
SWITCH: On Socket
SHADE: Off-white Softback
 5 ½" x 12" x 8 ½"
CORD: 11' Ivory,
 30" cord cover

➔ **WS-708-OB**

FINISH: Oil Rubbed Bronze
 HEIGHT: 16"
 ARM: Extends 19"
 BACKPLATE: 6 ¼" x 3 ½"
 BULB: One 100W Type A
 SWITCH: Hi/Lo on Back Plate
 SHADE: Off-white Softback
 5 ½" x 12" x 8 ½"
 CORD: 11' Ivory, 30" cord cover



← **WS-708-AB**

FINISH: Antique Brass
 HEIGHT: 16"
 ARM: Extends 19"
 BACKPLATE: 6 ¼" x 3 ½"
 BULB: One 100W Type A
 SWITCH: Hi/Lo on back plate
 SHADE: Off-white Softback
 5 ½" x 12" x 8 ½"
 CORD: 11' ivory,
 30" cord cover



← **WS-706-OB**

FINISH: Oil Rubbed Bronze
 HEIGHT: 16 ½"
 ARM: Extends 19"
 BACKPLATE: 6 ¼" x 3 ½"
 BULB: One 100W 3-way
 SWITCH: On Socket
 SHADE: Off-white Softback
 5 ½" x 12" x 8 ½"
 CORD: 11' ivory
 30" cord cover



Wall Swings



← WS-750-OB

FINISH: Oil Rubbed Bronze
 HEIGHT: 15"
 ARM: Extends 19"
 BACKPLATE: 5" x 6"
 BULB: One 100W 3-way
 SWITCH: On Socket
 SHADE: Off-white Linen Hardback
 5" x 12" x 8½"
 CORD: 11' Ivory, 30" cord cover



↑ WS-750-AS

FINISH: Antique Silver
 HEIGHT: 15"
 ARM: Extends 19"
 BACKPLATE: 5" x 6"
 BULB: One 100W 3-way
 SWITCH: On Socket
 SHADE: White Linen Hardback
 5" x 12" x 8½"
 CORD: 11' Ivory, 30" cord cover



↑ WS-750-AB

FINISH: Antique Brass
 HEIGHT: 15"
 ARM: Extends 19"
 BACKPLATE: 5" x 6"
 BULB: One 100W 3-way
 SWITCH: On Socket
 SHADE: Off-white Linen Hardback
 5" x 12" x 8½"
 CORD: 11' Ivory, 30" cord cover



↑ **WS-752-OB**

- FINISH: Oil Rubbed Bronze
- HEIGHT: 14"
- ARM: Extends 19"
- BACKPLATE: 4¾" x 4¾"
- BULB: One 100W 3-way
- SWITCH: On Socket
- SHADE: Off-white Linen Hardback
8" x 9" x 8"
- CORD: 11' Ivory, 30" cord cover



↑ **WS752-AS**

- FINISH: Antique Silver
- HEIGHT: 14"
- ARM: Extends 19"
- BACKPLATE: 4¾" x 4¾"
- BULB: One 100W 3-way
- SWITCH: On Socket
- SHADE: White Linen Hardback
8" x 9" x 8"
- CORD: 11' Ivory, 30" cord cover



← **WS752-AB**

- FINISH: Antique Brass
- HEIGHT: 14"
- ARM: Extends 19"
- BACKPLATE: 4¾" x 4¾"
- BULB: One 100W 3-way
- SWITCH: On Socket
- SHADE: Off-white Linen Hardback
8" x 9" x 8"
- CORD: 11' Ivory, 30" cord cover

Wall Swings



← **WS751-AB**

FINISH: Antique Brass
 HEIGHT: 15"
 ARM: Extends 19"
 BACKPLATE: 6" x 6"
 BULB: One 100W 3-way
 SWITCH: On Socket
 SHADE: Off-white Linen Hardback
 6" x 9" x 8 1/2"
 CORD: 11' Ivory, 30" cord cover



← **WS751-OB**

FINISH: Oil Rubbed Bronze
 HEIGHT: 15"
 ARM: Extends 19"
 BACKPLATE: 6" x 6"
 BULB: One 100W 3-way
 SWITCH: On Socket
 SHADE: Off-white Linen Hardback
 6" x 9" x 8 1/2"
 CORD: 11' Ivory, 30" cord cover



→ **LL623-SN**

FINISH: Satin Nickel
 HEIGHT: 17"
 ARM: Extends 9 1/2"
 BACKPLATE: 5 1/2" Round
 BULB: One 100W Type A +25R14N
 SWITCH: Rotary On Socket
 SHADE: White Linen Hardback
 8" x 10" x 8"
 CORD: 10' Ivory, 30" cord cover



↑ **WS751-AS**

FINISH: Antique Silver
 HEIGHT: 15"
 ARM: Extends 19"
 BACKPLATE: 6" x 6"
 BULB: One 100W 3-way
 SWITCH: On Socket
 SHADE: White Linen Hardback
 6" x 9" x 8 1/2"
 CORD: 11' Ivory, 30" cord cover



← **LL623-OB**

FINISH: Oil Rubbed Bronze
 HEIGHT: 17"
 ARM: Extends 9 1/2"
 BACKPLATE: 5 1/2" Round
 BULB: One 100W Type A +25R14N
 SWITCH: Rotary On Socket
 SHADE: Off-white Linen Hardback
 8" x 10" x 8"
 CORD: 10' Ivory, 30" cord cover

WALL SWING LAMPS



← WS16-91

FINISH: Oil Rubbed Bronze
HEIGHT: 15 1/2"
ARM: Extends 20"
BACKPLATE: 6" x 4 1/2"
BULB: One 100W 3-way
SWITCH: On Socket
SHADE: Off-white Linen Hardback
 5 1/2" x 12 1/2" x 9 1/4"
 Attaches with harp and finial
CORD: 11' Ivory, 30" cord cover



↑ WS16-61

FINISH: Polished Brass
HEIGHT: 15 1/2"
ARM: Extends 20"
BACKPLATE: 6" x 4 1/2"
BULB: One 100W 3-way
SWITCH: On Socket
SHADE: Off-white Linen Hardback
 5 1/2" x 12 1/2" x 9 1/4"
 Attaches with harp and finial
CORD: 11' Ivory, 30" cord cover

← WS16-31

FINISH: Pewter
HEIGHT: 15 1/2"
ARM: Extends 20"
BACKPLATE: 6" x 4 1/2"
BULB: One 100W 3-way
SWITCH: On Socket
SHADE: White Linen Hardback
 5 1/2" x 12 1/2" x 9 1/4"
 Attaches with harp and finial
CORD: 11' Ivory, 30" cord cover



↑ **COR100-SN**
 FINISH: Satin Nickel w/ Art Glass
 HEIGHT: 4½"
 EXTENSION: 3¾"
 BACKPLATE: 4½" x 4½"
 SHADE: 14"

COR100-SN shown
for unlit glass sample



Finishes

Antique Brass AB
 Oil Rubbed Bronze OB
 Satin Nickel SN



↑ **COR101-AB**
 FINISH: Antique Brass
 HEIGHT: 4½"
 EXTENSION: 3¾"
 BACKPLATE: 4½" x 4½"
 SHADE: 14"

↑ **COR100-OB**
 FINISH: Oil Rubbed Bronze
w/ Art Glass
 HEIGHT: 4½"
 EXTENSION: 3¾"
 BACKPLATE: 4½" x 4½"
 SHADE: 14"

↓ **COR102-SN**
 FINISH: Satin Nickel
 HEIGHT: 5½"
 EXTENSION: 3¾"
 BACKPLATE: 5½" Diameter
 SHADE: 13"

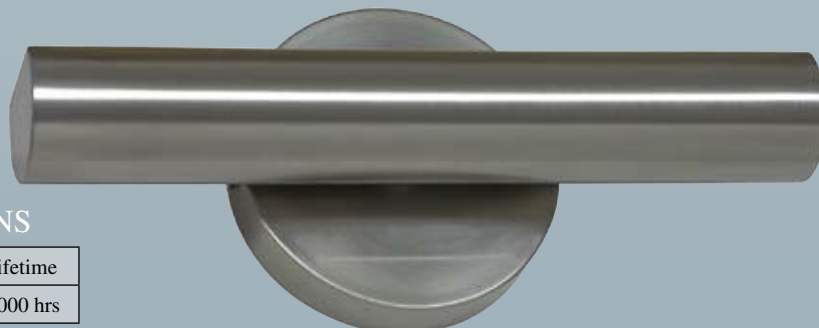

FLUORESCENT SPECIFICATIONS

Bulb	CRI	CCT	Watts	Lumens	Lifetime
F8T5-WW	82	3000K	8	460	5,000 hrs

Contract Picture Light



Finishes

- Black #7
- White #9
- Satin Brass #51
- Satin Nickel #52
- Polished Brass #61
- Chrome #62
- Antique Brass #71
- Weathered Brass #76
- Oil Rubbed Bronze #91

NOTE: Custom orders available on request.

SIZE SELECTION

Shade length should be one half the width of the image it is illuminating.



↓ **CPL24-71**

FINISH: Antique Brass (shown)
SWITCH: In-line
CORD: 8' Ivory

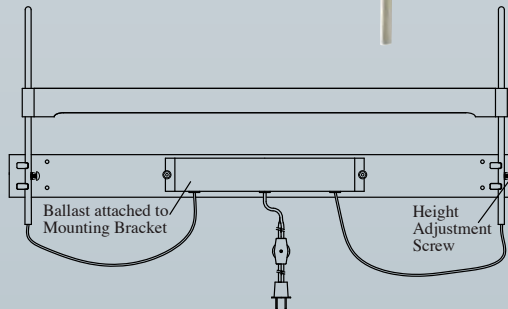
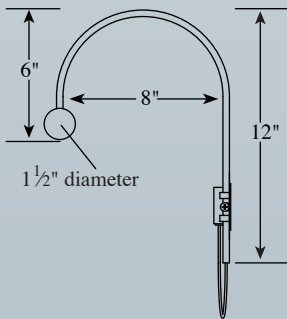

FLUORESCENT SPECIFICATIONS

Shade Size	Bulb	CRI	CCT	Watts	Lumens	Lifetime
24"	F14-T5	82	3000K	14	1200	15,000 hrs.
36"	F21-T5	82	3000K	21	1900	15,000 hrs.
48"	F28-T5	82	3000K	28	2600	15,000 hrs.

Bulbs not included. Non stock item, call for lead time and availability.

Direct Wire Fluorescent Picture Lights

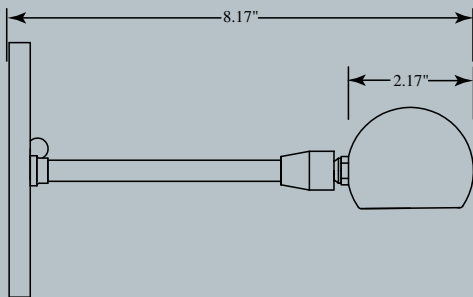

Finishes

- Satin Brass #51
- Satin Nickel #52
- Antique Brass #71

↑ **DCF12-52**

FINISH: Satin Nickel
HEIGHT: 4 1/2"
BACKPLATE: 4 1/2" x 8" x 3/8"

FLUORESCENT SPECIFICATIONS

Shade Size	Bulb	CRI	CCT	Watts	Lumens	Lifetime
12"	F8-T5	82	3000K	8	460	5,000 hrs.
24"	F13-T5	82	3000K	13	680	5,000 hrs.

Bulbs Included with 12", not with 24"

Classic Traditional™



Specifications

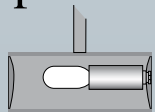

T4" & T5" shades
one 15T7F bulb

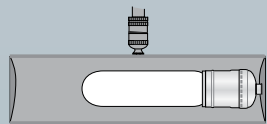

T8" and T9" shades
one 25 or 40T10F bulb

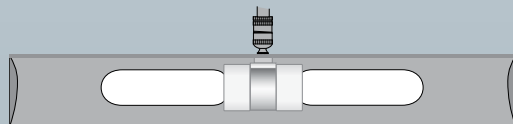

T14" and T18" shades
two 25 or 40T10F bulbs

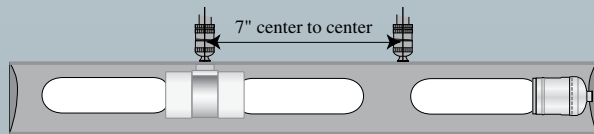

T21" shade
three 25 or 40T10F bulbs

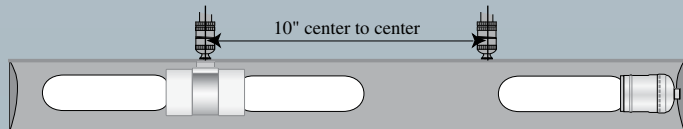

T24" shade
three 25 or 40T10F bulbs

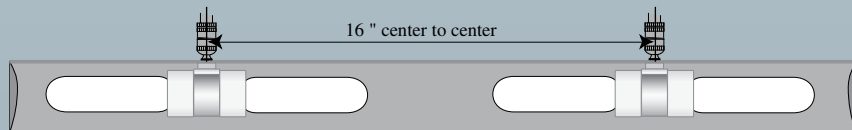

T30" shade
four 25 or 40T10F bulbs

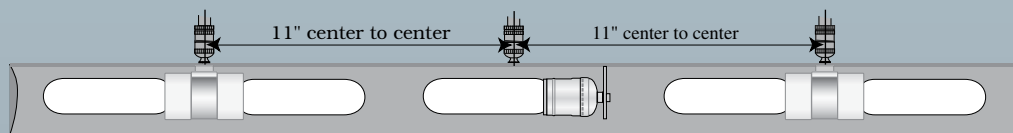

T36" shade
five 25 or 40T10F bulbs

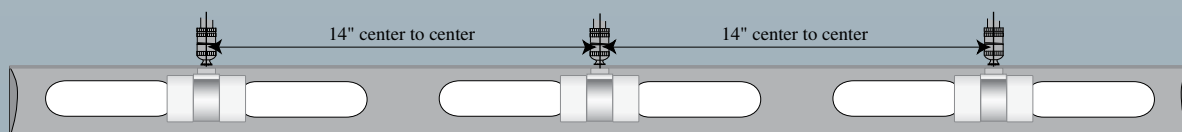

T42" shade
six 25 or 40T10F bulbs

SIZE SELECTION

Shade length should be one half the width of the image it is illuminating.

NOTE:

Traditional Series Picture Lights with more than one arm, have a UL-LISTED, pre-wired, aluminum splice-box (2" x 2" x 5/8") that hangs behind the artwork.



T24-51

Craftsmanship and reliability are traditions at House of Troy.

Finishes

- Gold #1
- Gold Wrinkle #2
- Bronze #5
- Pewter #31
- Satin Brass #51
- Statuary Bronze #56
- Polished Brass #61
- Antique Brass #71
- Weathered Brass #76
- Mahogany Bronze #81

NOTE: Custom orders available on request.



T14-1

Features

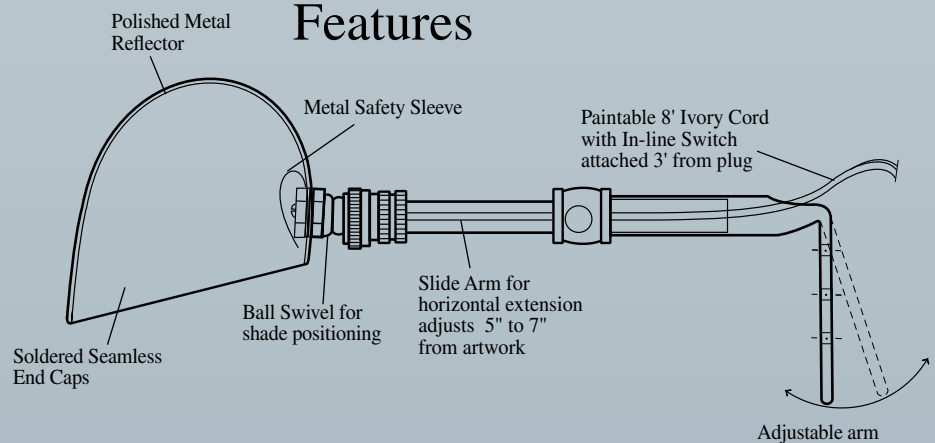

There are 25 procedures involved in the assembly of a Classic Traditional™ picture light. This hands-on assembly process assures a quality product.

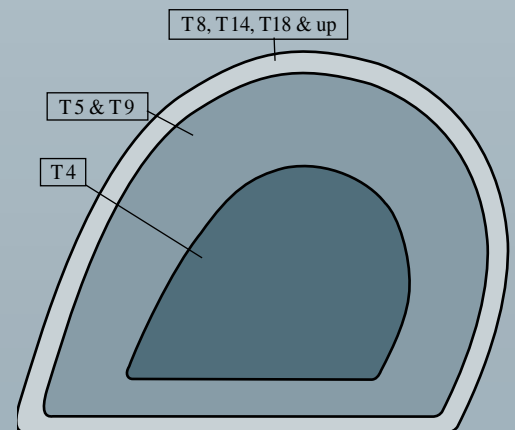

END CAP PROFILES ACTUAL SIZE

Classic Contemporary™



C9-52

- ### Finishes
- Gold #1
 - Satin Brass #51
 - Satin Nickel #52
 - Polished Brass #61
 - Chrome #62

Features

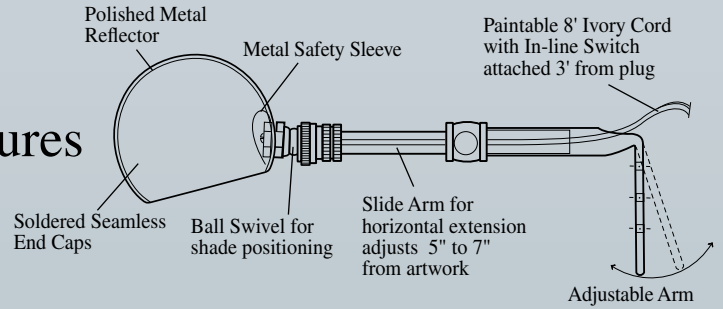

Specifications

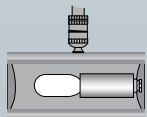

C5" shade
one 15T7F bulb

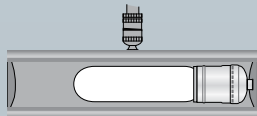

C9" shade
one 25 or 40T10F bulb

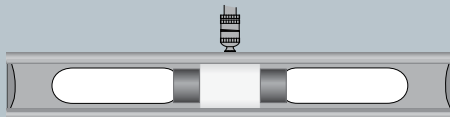

C16" shade
two 25 or 40T10F bulbs

SIZE SELECTION
 Shade length should be one half the width of the image it is illuminating.



C9-52



MA14-AB

Mantel Light



MA14-B

HEIGHT: 4½" BASE: 15" wide, 3" deep
 10' Brown Cord Exits Back of Shade.
 In-Line Switch 15" from Fixture.

Finishes

- Polished Brass (B)
- Antique Brass (AB)
- Mahogany Bronze (MB)

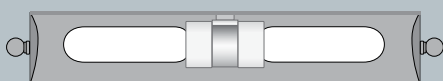

MA14"
two 25 or 40T10F bulbs

Classic Direct Wire™

Our Classic Direct Wire™ Picture Lights are ideal in a commercial setting where lighting needs to be permanently affixed to the wall. Direct Wire™ is also a solution for those who object to seeing the cord.

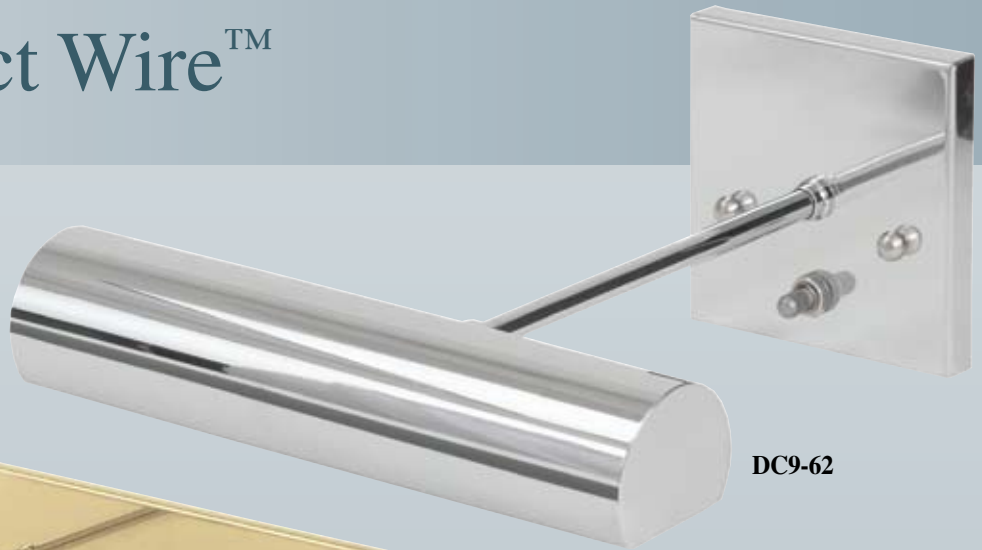

DC9-62

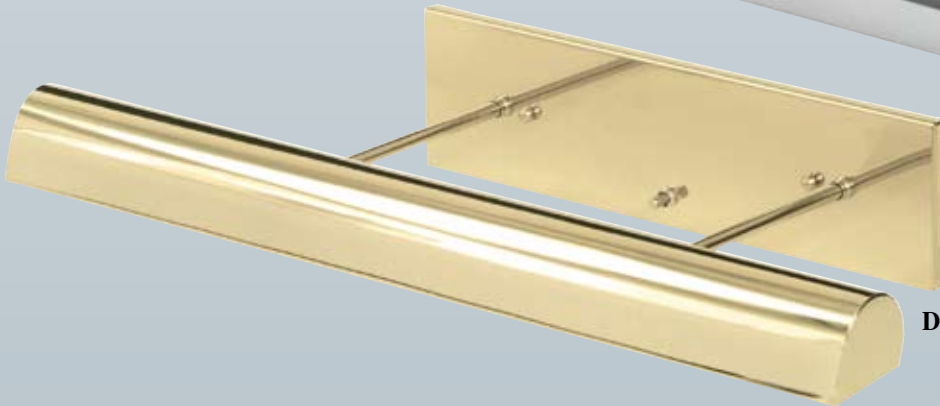

DT24-61

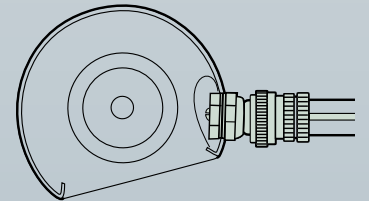

Contemporary Shade Profile

Features

Direct Wire™ Picture Lights are designed to mount over standard 2" x 4", 4" x 4" or octagonal boxes.

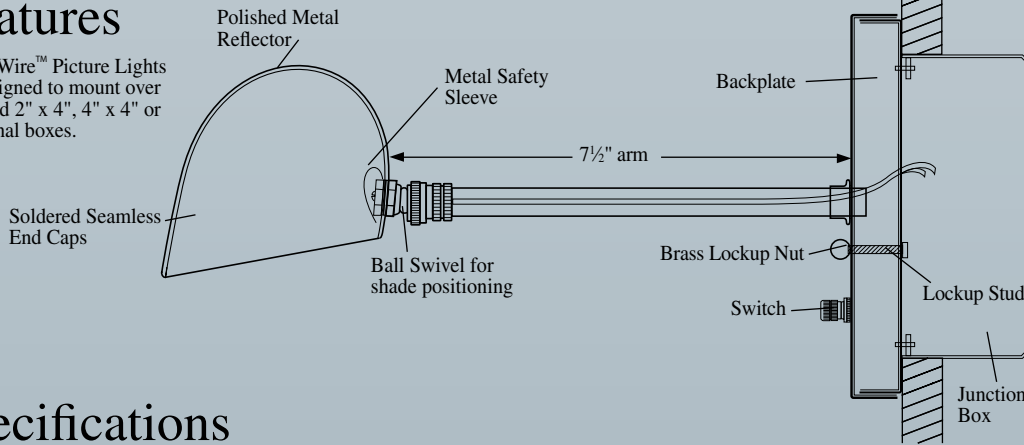

Finishes

- TRADITIONAL**
- Polished Brass #61
- Mahogany Bronze #81
- CONTEMPORARY**
- Polished Brass #61
- Chrome #62

NOTE: Custom orders available on request.

Specifications

TRADITIONAL

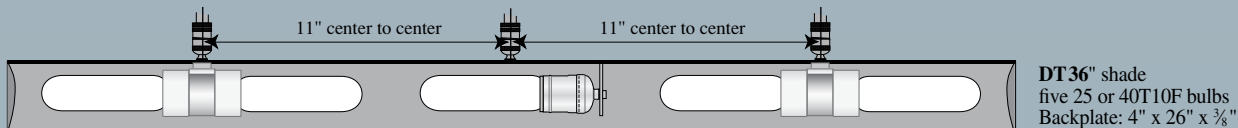
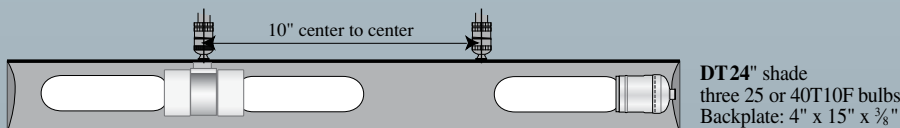
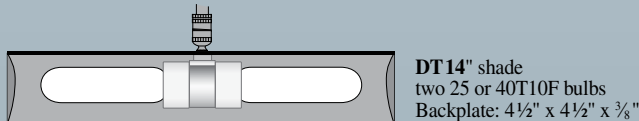
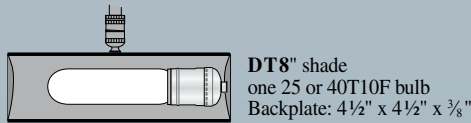

CONTEMPORARY



SIZE SELECTION
Shade length should be one half the width of the image it is illuminating.

Classic Traditional™ LED



Finishes

- Gold #1
- Gold Wrinkle #2
- Bronze #5
- Pewter #31
- Satin Brass #51
- Statuary Bronze #56
- Polished Brass #61
- Antique Brass #71
- Weathered Brass #76
- Mahogany Bronze #81

SIZE SELECTION

Shade length should be one half the width of the image it is illuminating.



TLED14-7 1

LED SPECIFICATIONS

Shade Sizes	CRI	CCT	Watts	Lumens	Lifetime	Equivalent Incandescent
10"	93	3400K	1.6	38.4	30,000 hrs	(1) 25 Watt
14"	93	3400K	2.4	57.6	30,000 hrs	(2) 25 Watt
24"	93	3400K	4	96	30,000 hrs	(3) 25 Watt
36"	93	3400K	6.4	153.6	30,000 hrs	(5) 25 Watt

Features

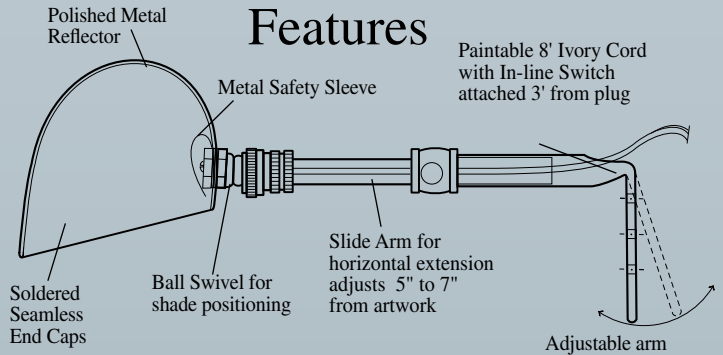

DTLED14-61

Classic Direct Wire™ LED



Finishes

- Polished Brass #61
- Mahogany Bronze #81

NOTE: Custom orders available on request.

BACKPLATE DIMENSIONS

DTLED10/14	4½" x 4½" x ½"
DTLED24	4" x 15" x ½"
DTLED36	4" x 26" x ½"

House of Troy Richardson Reflector

Finish

Gold #1

Features

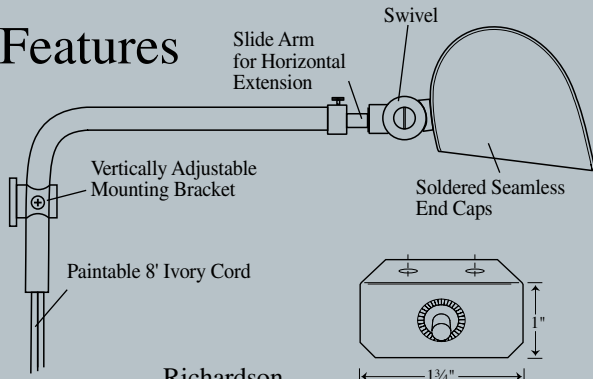

Richardson FRAME SWITCH (FRSW)

Optional Type "D" Switch, attaches to back of frame (switch sold separately).

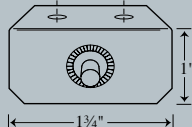

RR8-1

SIZE SELECTION

Shade length should be one half the width of the image it is illuminating.

Specifications

RR5" shade
one 15T7F bulb
arm extends 5" to 7"

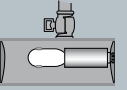

RR8" shade
one 25 or 40T10F bulb
arm extends 5" to 7"

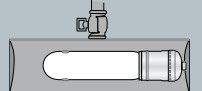

RR14" shade
two 25 or 40T10F bulbs
arm extends 7" to 9"

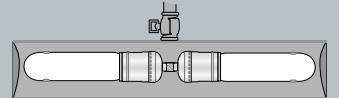

RR24" shade
three 25 or 40T10F bulbs
arm extends 8" to 10"

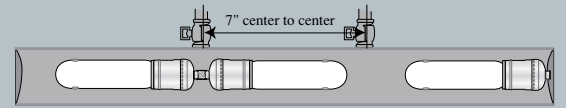

RR30" shade
four 25 or 40T10F bulbs
arm extends 8" to 10"

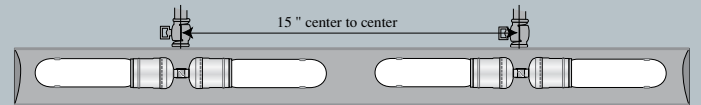

Hyde Park Collection

HP16-91

SIZE SELECTION

Shade length should be one half the width of the image it is illuminating.



Specifications

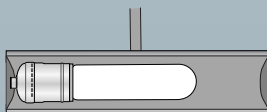

HP8" shade
one 25 or 40T10F bulb

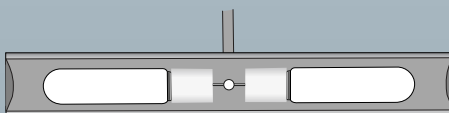

HP16" shade
two 25 or 40T10F bulbs

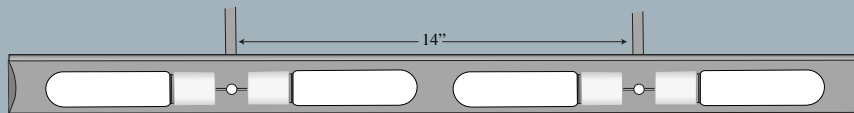

HP30" shade
four 25 or 40T10F bulbs

Features

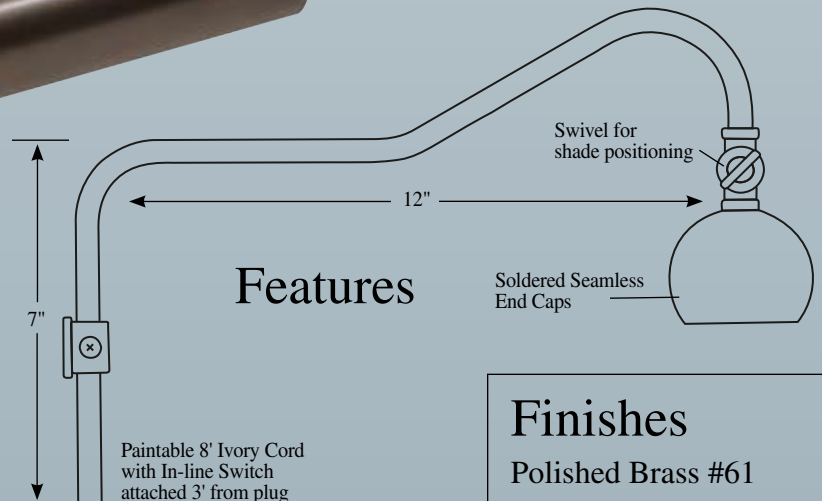

Finishes

- Polished Brass #61
- Antique Brass #71
- Weathered Brass #76
- Oil Rubbed Bronze #91

NOTE: Custom orders available on request.

SL Series Slim-Line™

The distinctive Slim-line™ light features even light distribution and reduced glare.



SL16-61

- ### Finishes
- Black #7
 - White #9
 - Satin Brass #51
 - Satin Nickel #52
 - Polished Brass #61
 - Chrome #62
 - Antique Brass #71
 - Weathered Brass #76
 - Oil Rubbed Bronze #91

NOTE: Custom orders available on request.

Features

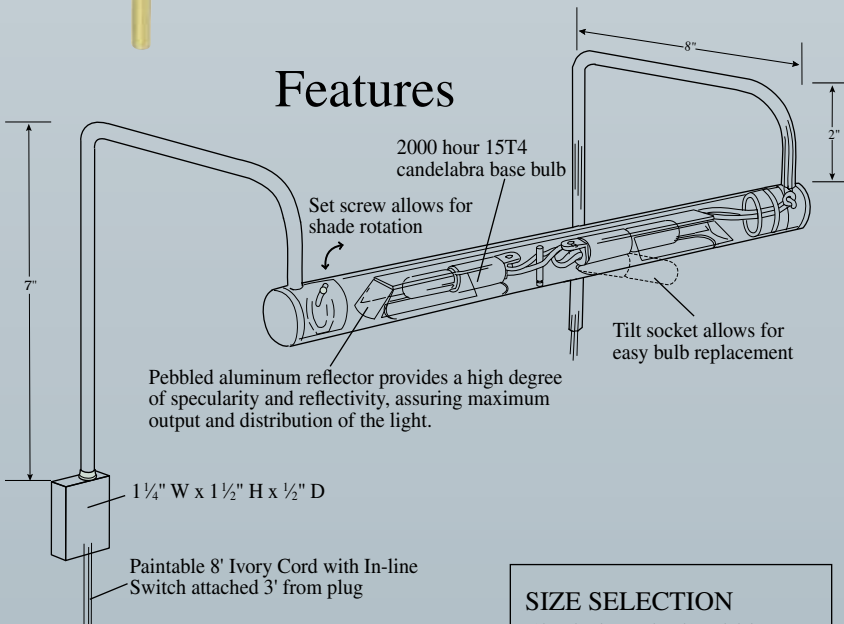

SIZE SELECTION
Shade length should be one half the width of the image it is illuminating.

Specifications

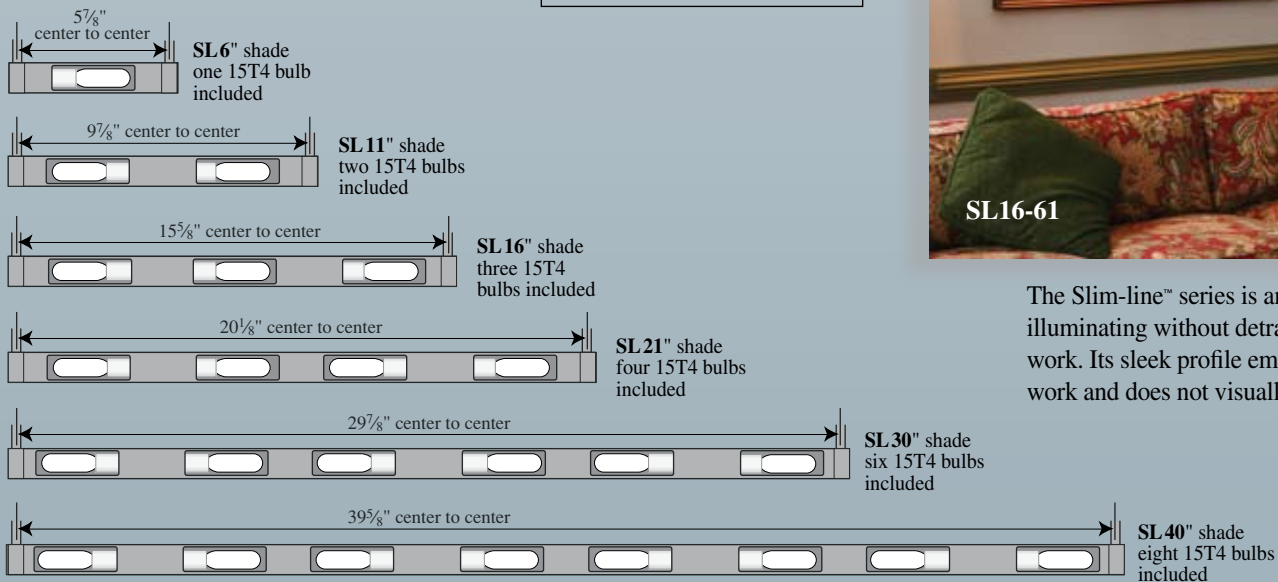

Non stocked lamps available with three arms in 64" and 84" lengths.



SL16-61

The Slim-line™ series is an excellent way of illuminating without detracting from the art work. Its sleek profile emphasizes the art work and does not visually intrude.

Direct Wire Slim-line™

Finishes

- Satin Brass #51
- Satin Nickel #52
- Antique Brass #71
- Oil Rubbed Bronze #91

SIZE SELECTION
Shade length should be one half the width of the image it is illuminating.

BACKPLATE: 2 3/4" x 4 1/2"



NOTE: Custom orders available on request.



DSL24-52

Specifications

BACKPLATE: 2 3/4" x 17 1/2"

DSL36-51

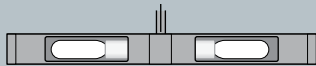

DSL14" shade
two 15T4 bulbs
included

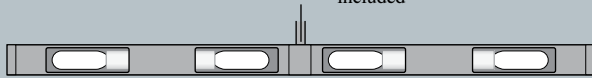

DSL24" shade
four 15T4 bulbs
included

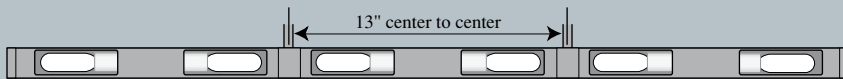

DSL36" shade
six 15T4 bulbs
included

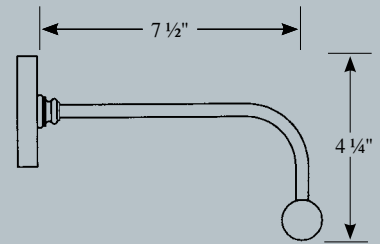

NOTE: Custom orders available on request.

XL Series Slim-line™

The distinctive Slim-line™ light features even light distribution and reduced glare.

XL12-61



Features

Pebbled aluminum reflector provides a high degree of specularly and reflectivity, assuring maximum output and distribution of the light.

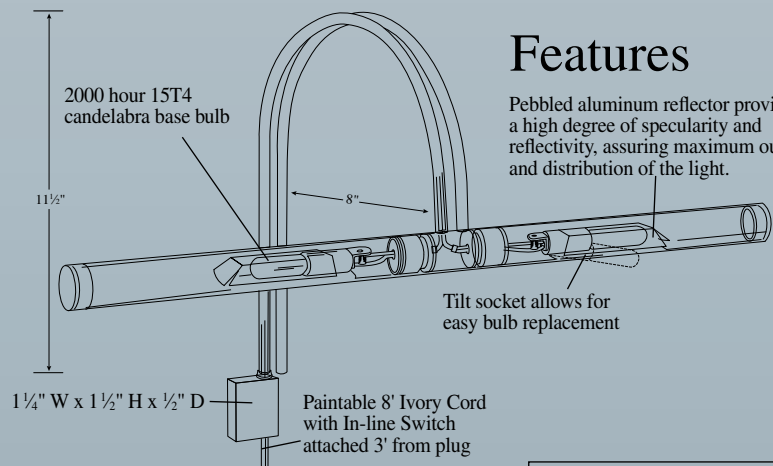

SIZE SELECTION
Shade length should be one half the width of the image it is illuminating.



XL12" shade
two 15T4 bulbs
included



XL22" shade
four 15T4 bulbs
included

Finish
Polished Brass #61

NOTE: Custom orders available on request.

Specifications

1 1/4" W x 1 1/2" H x 1/2" D

Paintable 8' Ivory Cord with In-line Switch attached 3' from plug

Slim-LED™ PICTURE LIGHT



ADA
COMPLIANT



SLED-20

Finishes

- Satin Nickel #52
- Polished Brass #61
- Chrome #62
- Antique Brass #71

SIZE SELECTION
Shade length should be one half the width of the image it is illuminating.

LED SPECIFICATIONS

Shade Size	CRI	CCT	Watts	Lumens	Lifetime	Equivalent Incandescent
20"	75	3000K	2.2	80	30,000 hrs	(4) 15 Watt

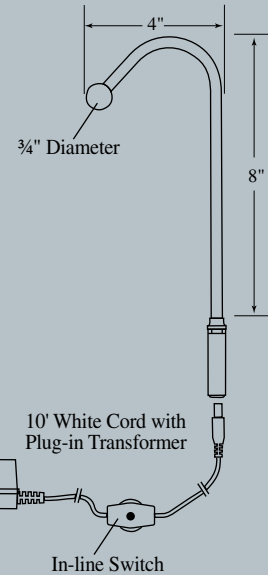

Direct Wire Slim-line™ LED



DSLED14-71

Finishes

- Satin Brass #51
- Satin Nickel #52
- Antique Brass #71
- Oil Rubbed Bronze #91

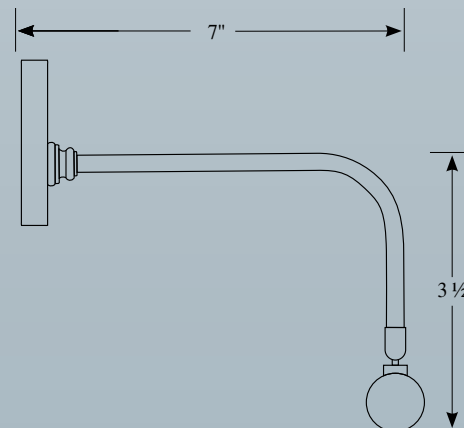

SIZE SELECTION
Shade length should be one half the width of the image it is illuminating.

LED SPECIFICATIONS

Shade Size	CRI	CCT	Watts	Lumens	Lifetime	Equivalent Incandescent
14"	93	3400K	2.4	57.6	30,000 hrs	(2) 15 Watt
24"	93	3400K	4	96	30,000 hrs	(4) 15 Watt

Battery Operated Slim-line™ LED

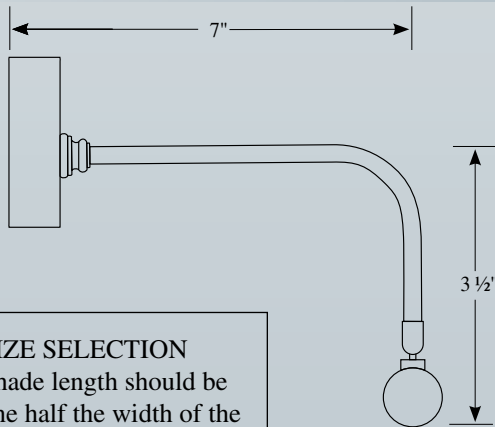

SIZE SELECTION
Shade length should be one half the width of the image it is illuminating.

BSLED14-91



Finishes
Satin Brass #51
Satin Nickel #52
Antique Brass #71
Oil Rubbed Bronze #91



LED SPECIFICATIONS

BTLED/BSLED						
Shade Size	CRI	CCT	Watts	Lumens	Lifetime	Equivalent Incandescent
14"	75	3000K	1.6	43.6	30,000 hrs	(2) 25 Watt

Uses 4 C Batteries (not included). Switch on LED array.

Battery Operated Traditional LED



BTLED14-51

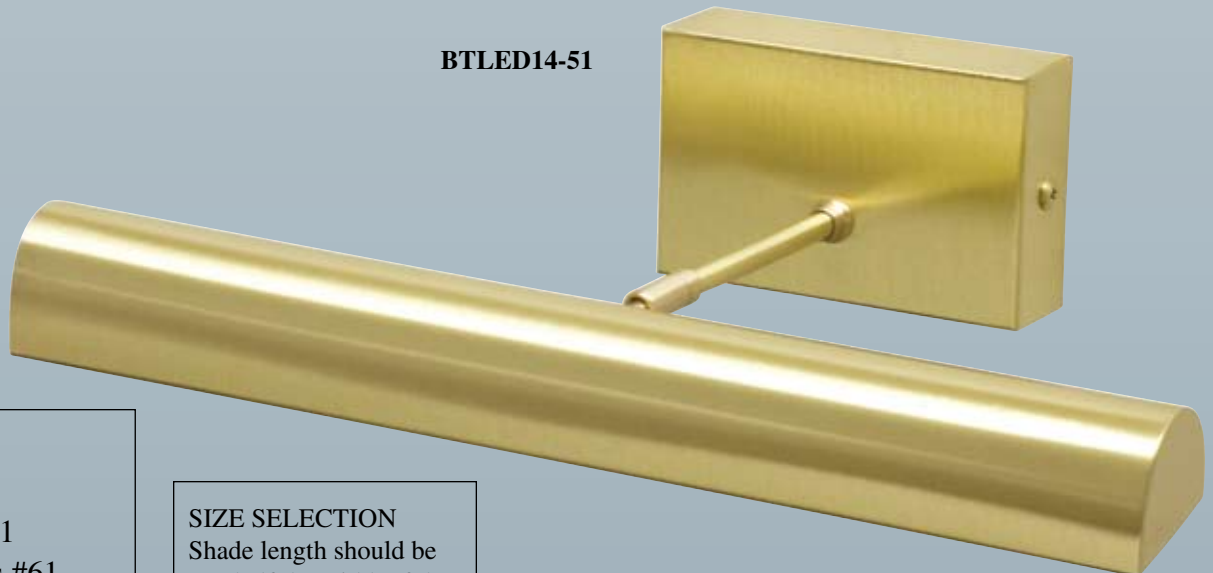

Finishes
Gold #1
Satin Brass #51
Polished Brass #61
Antique Brass #71
Mahogany Bronze #81

SIZE SELECTION
Shade length should be one half the width of the image it is illuminating.



ALED15-1

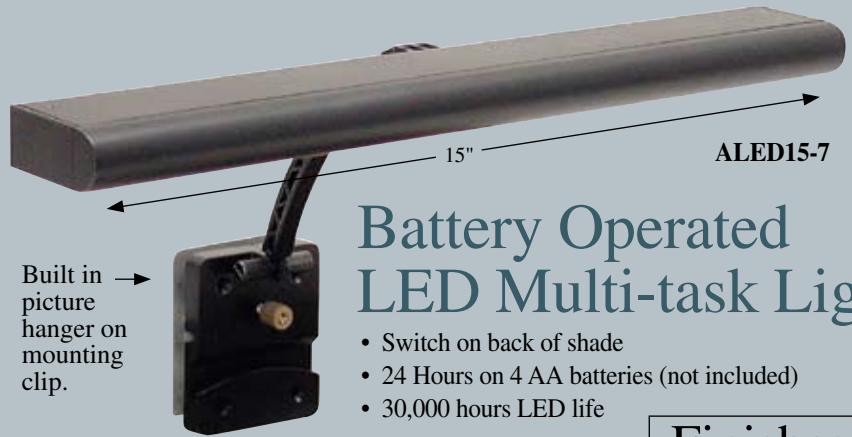

Built in picture hanger on mounting clip.

Clip: 2 3/8" W x 3" H,
Expands to fit surfaces up to 3/4" wide.

Battery Operated LED Multi-task Light

- Switch on back of shade
- 24 Hours on 4 AA batteries (not included)
- 30,000 hours LED life

Finishes

- Gold #1
- Black #7

Advent™ CORDLESS

14" Fluorescent

UV Tested—Safe For Artwork, Maximum Light Output Up To 45 Hours with 4 D batteries (not included).

Finishes

- Satin Nickel #52
- Brass #61
- Antique Brass #71



ABF14-71

Practical only where power is not available.

7" Incandescent →

Illuminates 6–8 hours with only 4 AA batteries (not included).

Finishes

- Polished Brass #61
- Antique Brass #71



AB7-61

Classic Rechargeable Battery Operated

Rechargeable Battery Operates 6–8 hours per charge.

Recharger included.

Shade Length and Bulb Information



RT8"
One #40, 8 hour and one #46, 6 hour bulb included

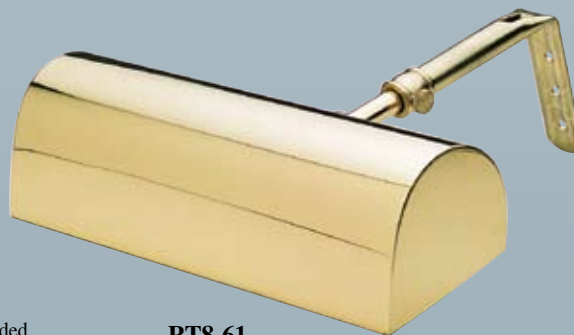

RT8-61

Practical only where power is not available.

Finishes

- Gold #1
- Statuary Bronze #56
- Polished Brass #61

AdventTM STANDARD



A7-71



A14-61

This light combines simple construction with moderate pricing. It has many quality features and is a reliable lighting alternative.

Finishes

- Polished Brass #61
- Antique Brass #71

Specifications

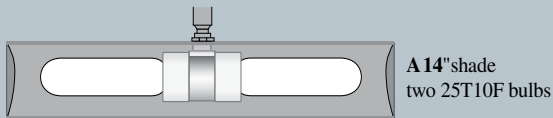
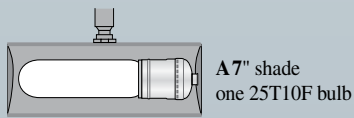

Features

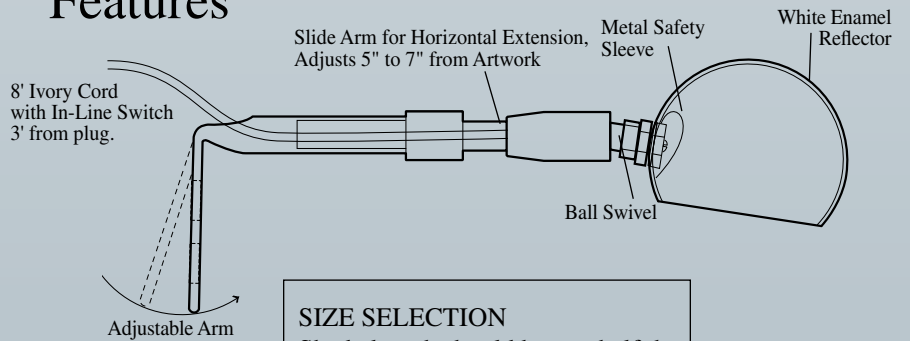

SIZE SELECTION

Shade length should be one half the width of the image it is illuminating.



AG-7



AG-51

AdventTM GEMINI

SIZE GUIDE

- AG uses 50W Standard Flood (included). Illuminates up to 3' x 5' area
- AG uses 50W Narrow Flood (optional). Illuminates up to 3' x 3' area

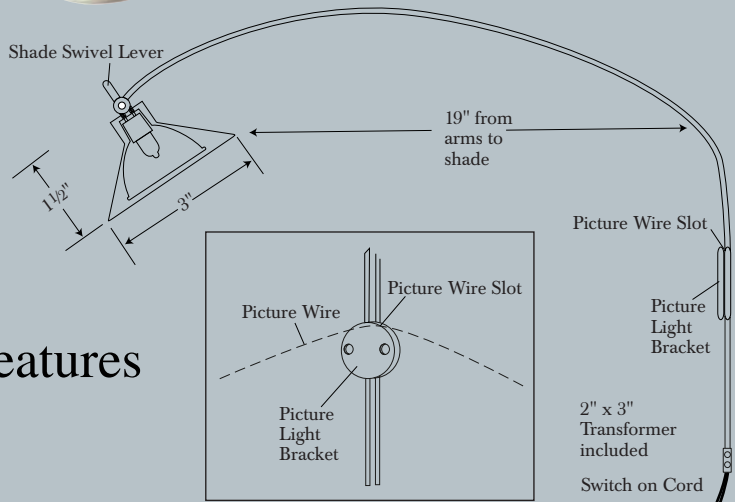

Features

Finishes

- Black #7
- Satin Brass #51
- Satin Nickel #52
- Antique Brass #71

Advent™ PROFILE

The Profile light uses incandescent bulbs and is available in a 16" length.



Finishes

- Black #7
- Satin Nickel #52
- Polished Brass #61
- Antique Brass #71

APR16-61

SIZE SELECTION

Shade length should be one half the width of the image it is illuminating.

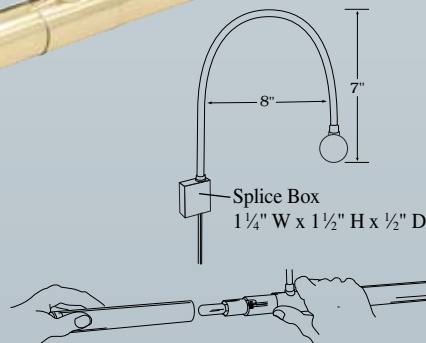

Shade removes for easy bulb replacement and rotates for light adjustment on APR16



APR16-7

The black finish of the Profile light matches and complements the frame and art work.

Specifications

APR16" shade
two 15T4 bulbs
included



Advent™ HALOGEN

The Halogen Profile light is UV filtered and gives off a more natural and whiter light. Transformer included.

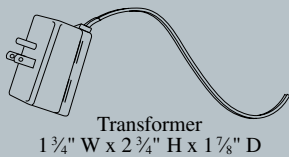

Transformer
1 3/4" W x 2 3/4" H x 1 7/8" D

Finishes

- Black #7
- Satin Nickel #52
- Polished Brass #61
- Antique Brass #71



8' White Cord

APH16-52

Specifications



APH16" shade
two 20 Watt Halogen bulbs
included 73% UV filtered

Advent™

PORTABLE SPOT LIGHTS

Satin Nickel Finish

SWITCH: On 10' black cord,
18" from shade



Mini-cans

SP-510-52
HEIGHT: 6 ½"

SP-512-52
HEIGHT: 6 ½"



Table/Floor Spots

SP-520-52
HEIGHT: 6"

SP-530-52
HEIGHT: 6 to 9"

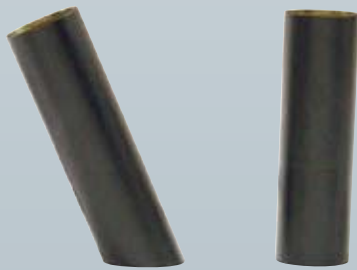

Mini-cans

SP-510-7
HEIGHT: 6 ½"

SP-512-7
HEIGHT: 6 ½"



Table/Floor Spots

SP-530-7
HEIGHT: 6 to 9"

SP-520-7
HEIGHT: 6"

Black Finish

SWITCH: On 10' black cord,
18" from shade

Bulbs
40R14N (included)

White Finish

SWITCH: On 10' white cord,
18" from shade



Mini-cans

SP-512-9
HEIGHT: 6 ½"

SP-510-9
HEIGHT: 6 ½"



Table/Floor Spots

SP-520-9
HEIGHT: 6"

SP-530-9
HEIGHT: 6 to 9"



Mini-cans

SP-510-61
HEIGHT: 6 ½"

SP-512-61
HEIGHT: 6 ½"



Table/Floor Spots

SP-530-61
HEIGHT: 6 to 9"

SP-520-61
HEIGHT: 6"

Polished Brass Finish

SWITCH: On 10' black cord,
18" from shade

Advent™ LIGHT STRIP

WITH SWIVELS

Finishes

- Black #7
- White #9
- Polished Brass #61



The accent light with many uses

China Cabinets, Stereo Racks, Trophy Cases, Under Shelf, Art/Sculpture, Night Lighting, Wall Units, Bookcases, etc.

ALS10-61



Length and Bulb Information



Bulbs last an average of 40,000 hours (6 watts per 10" of light strip). Bulbs are in a self-contained unit and are not replaceable.

Comes with 5' 9" cord, switch 3" from fixture.

Installs in minutes without tools.

Advent™ CLIP-ON LIGHT

Ideal for use with laptop computers, easels, music stands and home office spaces.



ACL7-7

Finish
Black #7

Quality Features

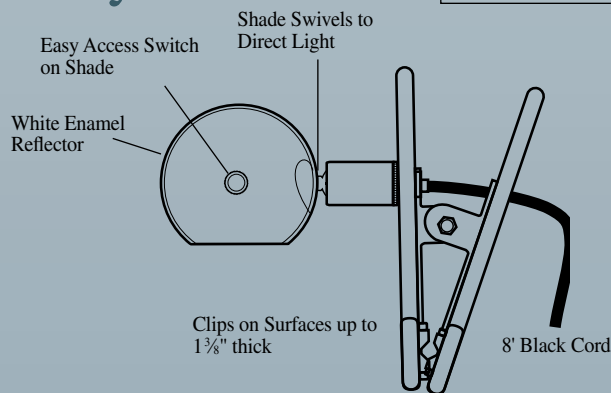

Littlite

High Intensity Halogen Lamp

Finish
Black #7

HL3-12

Black Cord, 5' 9"

Optional Accessory

RWB Weighted Base



HSM (Included)

Snap Mount allows quick attachment and detachment of lamp. One half of the HSM adheres to the lamp base and the other to a flat surface. The lamp then snaps on and off as desired.

Transformer, Snap Mount and Halogen bulb included

Product #	Bulb (included)	Gooseneck	Switch
HL3-12	5W	12"	dimmer
HL3-18	5W	18"	dimmer
HL4-12	10W	12"	on/off
HL4-18	10W	18"	on/off

Advent™ CABINET LIGHT

Quality Features

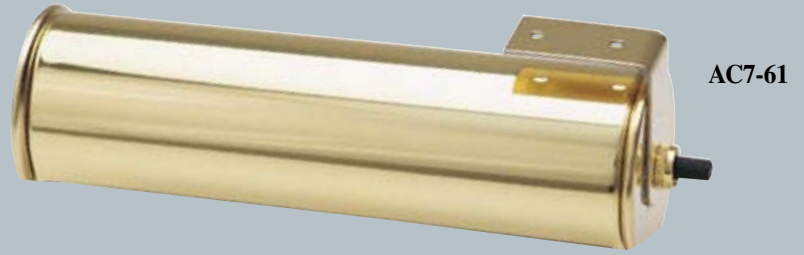
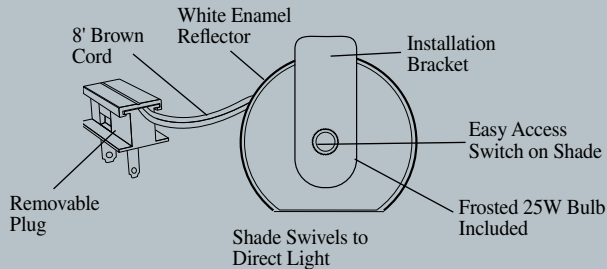

Shade Length and Bulb Location

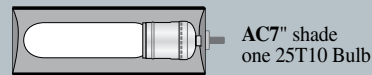

Finishes

Polished Brass #61
Antique Brass #71

LECTERN LIGHT

Designed to be permanently installed on surfaces up to 2" thick.



➔ **L10-61**
FINISH: Polished Brass
HEIGHT: 7"
1 3/4" Between Arms
SWITCH: On Shade
SHADE: 10"
CORD: 10' Brown with Snap-On Plug Included

Shade Length and Bulb Location



BED LAMPS



↑ **BL-10-PB**
FINISH: Polished Brass
HEIGHT: Gooseneck Adjusts from 0" to 8 1/2"
BASE: Adjustable clip Up to 2 1/2" Wide
BULB: One 40T10 or 60T10
SWITCH: On Shade
SHADE: 10"
CORD: 10' Brown



← **BL-10-AB**
FINISH: Antique Brass
HEIGHT: Gooseneck Adjusts from 0" to 8 1/2"
BASE: Adjustable clip Up to 2 1/2" Wide
BULB: One 40T10 or 60T10
SWITCH: On Shade
SHADE: 10"
CORD: 10' Brown

UC SERIES UNDER CABINET LIGHTS

Line Voltage Incandescent System

Includes:

- 10' Cord with Snap-on Plug
- Hardware to convert to Direct Wire

Quality Features

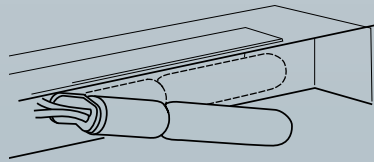
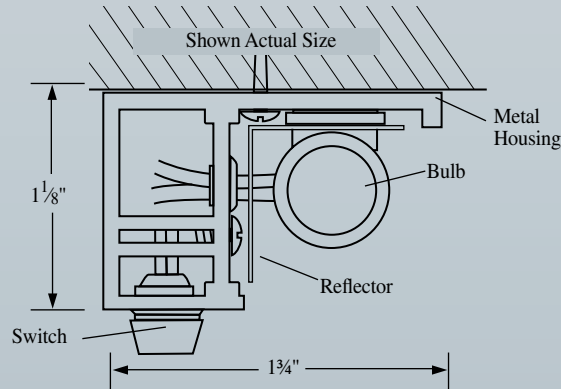

Tilt down feature for bulb replacement.



UC-18-32



UC-13-9

Specifications

Bulbs sold separately



Finishes

- White #9
- Brushed Aluminum #32
- Polished Brass #61

Custom Direct Mount Lights



A Classic Traditional Direct Mount Light illuminates a menu board.

House of Troy Direct Mount Lights can be installed into paneling. This is an attractive feature for library use and enhances the look of book shelves and display areas. Call our customer service department for quotes on this custom alternative.

All A, B, C dimensions may be modified to meet your specifications.

Classic Direct Mount

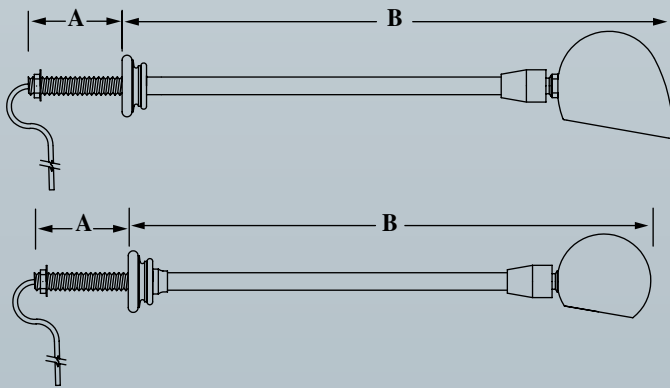

Library Direct Mount

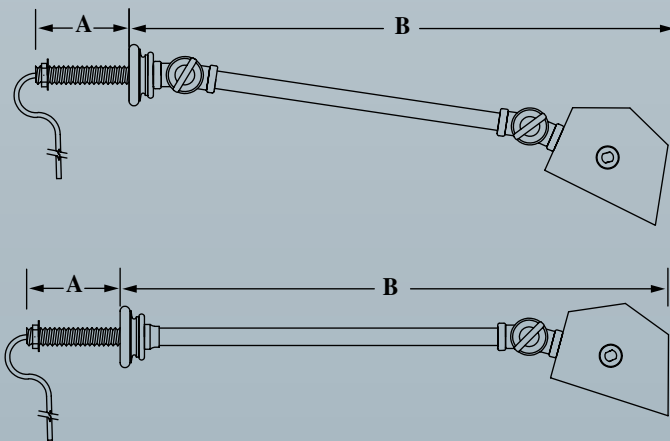

Slim-line Direct Mount

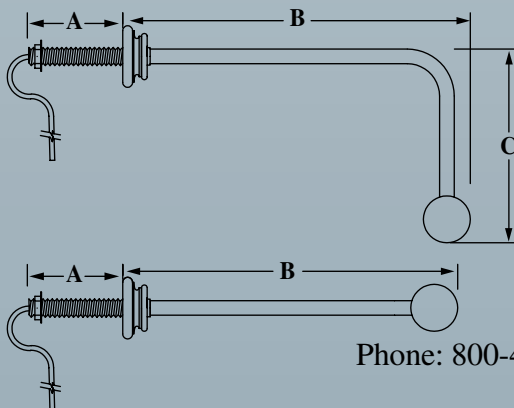

Illuminate your bookshelves with our Slim-line Custom Direct Mount Lights.

Mounting Detail

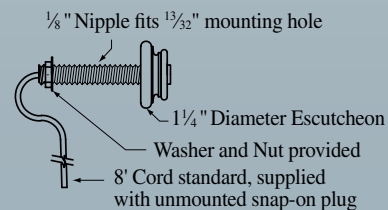

Questions & Answers

Q. What does LED stand for?

A. LED stands for Light Emitting Diode.

Q. Is a LED a bulb?

A. No, they are tiny semi-conductors encapsulated in plastic, which protect their components and help focus the light.

Q. Why do LEDs use such little power?

A. Incandescent bulbs create light by applying power to a filament, which glows and produces light and heat. LEDs do not use a filament, so produce very little heat, making them far more efficient in consumption and output.

Q. How long do LEDs last?

A. LEDs last from 30,000-100,000 hours. As LEDs get older they dim and fade, rather than burn out. Incandescent bulbs last between 1,000-2,000 hours.

Q. LEDs are more expensive than other lighting options, why?

A. LEDs require different components to operate properly, such as a circuit board, drivers or transformers, and housings. As demand for LED products has increased, costs have come down.

Q. What are CRI and CCT?

A. The Color Rendering Index (CRI) is a measure of the ability of a light source to reproduce the colors generated by a reference light source of the same color temperature. For example, a CRI of 100%, taken at a color temperature of noon day sunlight (5500K) will exactly reproduce the colors found on a sunny day at noon.

The Correlated Color Temperature (CCT) is a measurement used to define the color of a light source. It is used to indicate the “coolness” or “warmness” of a light. Color temperature of light is typically measured in degrees Kelvin or just Kelvin.

Examples of Color Temperature

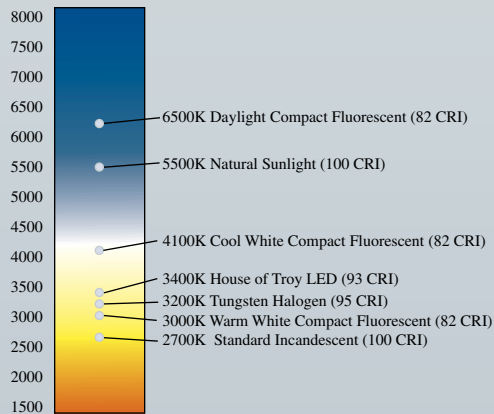

Q. Will I save money with LED lighting?

A. LEDs typically use 5-15% of the electricity of incandescent lighting. LED savings are found over the life of the LED in energy consumption. This does not include the cost of the 15-30 replacement incandescent bulbs over the life of the LED.

Q. Are LEDs harmful to my artwork?

A. House of Troy LED light output is of conservation quality. Our LEDs have no UV found in incandescent and fluorescent bulbs that can be harmful to your art.

Benefits of LEDs

- Low power consumption (costs less to light)
- Very efficient, focused light, little heat
- Extremely long life span (30,000-50,000 hrs)
- Durable, insensitive to vibration
- No UV
- Environmentally friendly (no mercury or other toxins)
- Recyclable

Q. What size picture light should I use?

A. Measure the width of the image and use a picture light approximately $\frac{1}{2}$ the size. Consider the lighting requirements of the room.

Q. What color picture light should I consider?

A. Depending on your personal taste, you may select a finish that matches your frame, or you may select a finish that stands on its own or is in keeping with the décor of the room.

Q. Is there a way to eliminate the cord?

A. There are several ways to deal with the cord:

1. Install a recessed outlet (sometimes called a “clock outlet”) behind the artwork. Making sure that the lamp is not plugged in, cut the cord to the appropriate length and attach a flat snap-on plug (available from House of Troy). Ideally, connect this to a dimmer switch on the wall.
2. Use Cord Covers.
3. Paint the cord to match the wall color.
4. Place furniture, plants, or other décor to hide most of the cord.
5. Use an insulated staple to attach the cord to the baseboard. This keeps the cord straight and improves its appearance.
6. Several battery-operated picture lights are available. These lights provide minimum light and will last up to 45 hours.

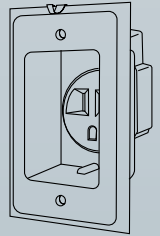

Q. What type of bulbs are used in picture lights?

A. Refer to the House of Troy brochure for size and wattage bulb. Remember to use a frosted bulb if the reflector in your light is smooth. Only use a clear bulb if the reflector is pebbled. A clear bulb with a smooth reflector produces unnecessary reflections on the artwork. A dimmer is an effective way to adjust the amount of light for your artwork.

Q. How do you install a picture light?

A. All House of Troy picture lights come with mounting hardware and may be attached to either the picture frame or the wall. The only tools necessary are a screw driver and something to start a screw-hole, such as a small nail or awl.

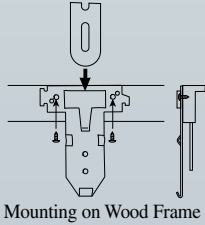

Mounting on Wood Frame

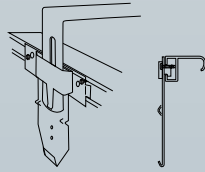

Mounting on Metal Frame

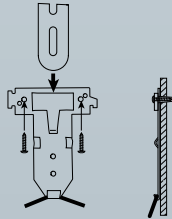

Mounting on Wall

Q. In what order are shade dimensions given in this catalog?

A. See drawing below.

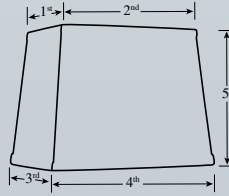
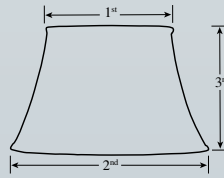

Q. How do you measure a Desk/Piano Lamp?

A. Adjustable Desk/Piano lamps are measured in the locations shown in the drawing below.

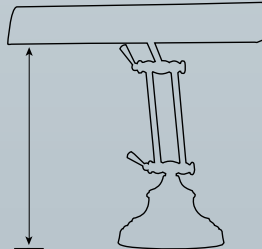

Q. How is the arm extension measured on Swing Arm Lamps?

A. On Wall Swings, the measurement is from the front of the backplate to the center of the socket. On Desk Lamps, the measurement is from the front of the post to the center of the socket.

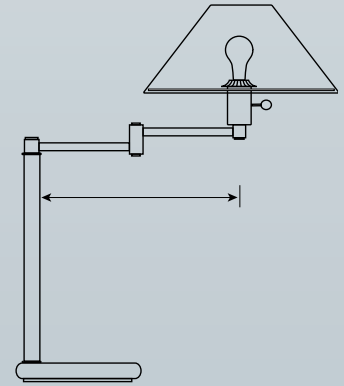

Q. How can we display these products in our store?

A. Call our Customer Service department for Picture Light display options.



Picture Light Finishes

Our Classic and Slim-line™ picture lights are offered in the most popular finishes. If you would like a finish that is not stocked, call our customer service department for lead time and cost.

The antique and weathered brass finishes are applied then rubbed by hand to achieve the proper effect. For this reason there are slight surface variations which are expected and desirable.

The stocked finishes are listed on the product page. Refer to this page for a color representation of finish.



Gold #1



Brushed Aluminum #32

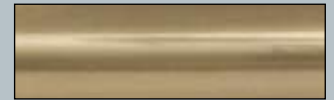

Antique Brass #71



Gold Wrinkle #2

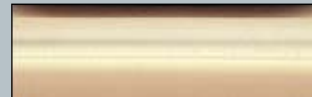

Satin Brass #51

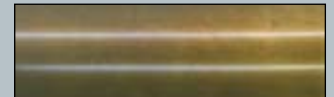

Weathered Brass #76

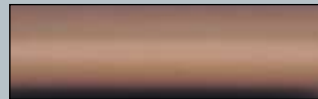

Bronze #5



Satin Nickel #52

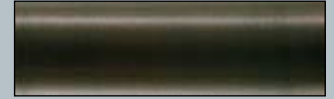

Mahogany Bronze #81



Black #7

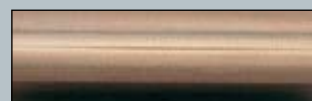

Statuary Bronze #56

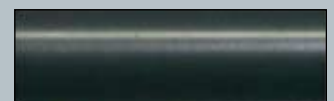

Oil Rubbed Bronze #91



White #9

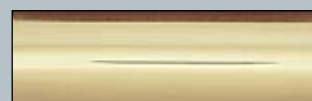

Polished Brass #61



Chestnut Bronze (CHB)

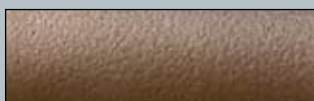

Hammered Bronze (HB)



Pewter #31



Chrome #62



Granite (GT)

ITEM	PAGE	ITEM	PAGE	ITEM	PAGE	ITEM	PAGE	ITEM	PAGE	ITEM	PAGE
A14-61	119	C5-1	110	CPL48-52	107	FLX100-CHB	43	HL4-18	122	N603-OB	84
A14-71	119	C5-51	110	CPL48-61	107	FLX125-AB	42	HP16-61	113	N603-PTR	84
A7-61	119	C5-52	110	CPL48-62	107	FLX125-CH	42	HP16-71	113	N604-AB	85
A7-71	119	C5-61	110	CPL48-7	107	FLX150-AB	42	HP16-76	113	N604-OB	85
AB7-61	118	C5-62	110	CPL48-71	107	FLX150-BLK	42	HP16-91	113	N604-PTR	85
AB7-71	118	C9-1	110	CPL48-76	107	FLX150-CHB	42	HP30-61	113	N606-AB	85
ABF14-52	118	C9-51	110	CPL48-91	107	G100-CHB	46	HP30-71	113	N606-OB	85
ABF14-61	118	C9-52	110	D435-51-F	59	G100-GT	46	HP30-76	113	N650-AB	80
ABF14-71	118	C9-61	110	D435-51-J	59	G150-CHB	45	HP30-91	113	N650-OB	80
AC7-61	123	C9-62	110	D435-91-F	59	G150-GT	45	HP700-OB-AG	69	N651-AB	78
AC7-71	123	CH800-AB	41	D435-91-J	59	G175-CHB	44	HP700-OB-BP	69	N651-OB	78
ACL7-7	122	CH800-AS	41	D436-52	60	G175-GT	44	HP700-OB-MSOB69		N651-PTR	78
AG-51	119	CH800-OB	41	D436-71	60	G200-CHB	46	HP700-OB-WL	69	N652-AB	80
AG-52	119	CH825-AB	40	D436-91	60	G200-GT	46	HP700-WB-AG	70	N652-OB	80
AG-7	119	CH825-AS	40	DC16-61	111	G200-HB	46	HP700-WB-BP	70	N653-AB	79
AG-71	119	CH825-OB	40	DC16-62	111	G200-WT	46	HP700-WB-MSWB70		N653-OB	79
ALED15-1	25/118	CH850-AB	38	DC9-61	111	G250-CHB	45	HP700-WB-WL	70	OL600-OB	77
ALED15-7	25/118	CH850-AS	38	DC9-62	111	G250-GT	45	HP725-OB-AG	65	OL600-WB	77
ALS10-61	122	CH850-OB	38	DCF12-51	107	G250-HB	45	HP725-OB-BP	65	OL650-OB	76
ALS10-7	122	CH875-OB	39	DCF12-52	107	G250-WT	45	HP725-OB-MSOB65		OL650-WB	77
ALS10-9	122	CH876-AB	39	DCF12-71	107	G275-CHB	44	HP725-OB-WL	65	OL651-OB	76
ALS20-61	122	CH877-AS	39	DCF24-51	107	G275-GT	44	HP725-WB-AG	66	OL651-WB	76
ALS20-7	122	CH878-AS	39	DCF24-52	107	G275-HB	44	HP725-WB-BP	66	P10-007-617	31
ALS20-9	122	CH879-AB	38	DCF24-71	107	G275-WT	44	HP725-WB-MSWB66		P10-007-627	31
ALS30-61	122	CH880-OB	39	DL10-OB	71	G300-BLK	47	HP725-WB-WL	66	P10-101-B	2
ALS30-7	122	CL200-AB	37	DL10-WB	71	G300-CHB	47	HP750-OB-AG	67	P10-107-61	3
ALS30-9	122	CL200-AS	37	DL20-OB	72	G300-GT	47	HP750-OB-BP	67	P10-107-81	3
AP10-20-61	16	CL200-OB	37	DL20-WB	72	G300-HB	47	HP750-OB-MSOB67		P10-108	4
AP10-20-7	16	CL201-AB	36	DSK428-G61	87	G300-WT	47	HP750-OB-WL	67	P10-111	4
AP10-20-71	16	CL201-AS	36	DSK428-G71	87	G350-BLK	48	HP750-WB-AG	68	P10-111-71	4
AP10-21-61	17	CL201-OB	36	DSK430-MB	87	G350-CHB	48	HP750-WB-BP	68	P10-111-MB	4
AP10-21-71	17	CL202-AB	35	DSL14-51	115	G350-GT	48	HP750-WB-MSWB68		P10-123	2
AP10-21-91	17	CL202-AS	35	DSL14-52	115	G350-HB	48	HP750-WB-WL	68	P10-123-81	2
AP10-22-61	17	CL202-OB	35	DSL14-71	115	G350-WT	48	HP775-OB-AG	64	P10-130	5
AP14-40-61	16	CL225-AB	33	DSL14-91	115	G375-BLK	49	HP775-OB-OG	64	P10-131-61	5
AP14-40-7	16	CL225-AS	33	DSL24-51	115	G375-CHB	49	HP775-WB-AG	64	P10-131-71	5
AP14-40-71	16	CL225-OB	33	DSL24-52	115	G375-GT	49	HP775-WB-OG	64	P10-150	20
AP14-41-61	15	CL250-AB	34	DSL24-71	115	G375-HB	49	HP8-61	113	P10-150-617	20
AP14-41-71	15	CL250-AS	35	DSL24-91	115	G375-WT	49	HP8-71	113	P10-152	3
AP14-41-91	15	CL250-OB	35	DSL36-51	115	GI750-AB	50	HP8-76	113	P10-163	2
AP14-42-61	17	CL251-AB	34	DSL36-52	115	GI750-OB	50	HP8-91	113	P10-165-627	3
APH16-52	120	CL251-AS	34	DSL36-71	115	GI751-AB	51	L10-61	123	P10-190-M	29
APH16-61	120	CL251-OB	34	DSL36-91	115	GI751-OB	51	LL623-OB	104	P10-191-52M	29
APH16-7	120	COR100-AB	106	DSLED14-51	116	GI775-AB	51	LL623-SN	104	P10-191-61	28
APH16-71	120	COR100-OB	106	DSLED14-52	116	GI775-OB	51	LL660-AB	73	P10-191-61C	28
APH16-71	120	COR100-SN	106	DSLED14-71	116	GP10-61	27	LL660-OB	73	P10-191-61M	29
APR16-52	120	COR101-AB	106	DSLED14-91	116	GP10-7	27	LL660-PB	73	P10-191-71	28
APR16-61	120	COR101-OB	106	DSLED24-51	116	GP10-81	27	LL660-SN	73	P10-191-81	28
APR16-7	120	COR101-SN	106	DSLED24-52	116	GP14-61	27	LL662A-AB	74	P10-192-617	31
APR16-71	120	COR102-AB	106	DSLED24-71	116	GP14-7	27	LL662A-OB	74	P10-192-627	31
BAR101-BB	32	COR102-OB	106	DSLED24-91	116	GP14-81	27	LL662A-PB	74	P14-201	12
BAR102-BB	32	COR102-SN	106	DT14-61	111	GPLED19-61	25	LL662A-SN	74	P14-201-81	12
BAR103-BB	32	CPL24-51	107	DT14-81	111	GPLED19-7	25	LL663-AB	75	P14-201-AB	12
BAR125-BB	32	CPL24-52	107	DT24-61	111	GPTLED-61	25	LL663-PB	75	P14-201-GT	12
BL10-AB	123	CPL24-61	107	DT24-81	111	GPTLED-7	25	LL663-SN	75	P14-202	11
BL10-PB	123	CPL24-62	107	DT36-61	111	GPXL22-61	26	MA14-AB	110	P14-202-81	11
BSLED14-51	117	CPL24-7	107	DT36-81	111	GPXL-617	26	MA14-B	110	P14-202-AB	11
BSLED14-52	117	CPL24-71	107	DT8-61	111	GPXL-627	26	MA14-MB	110	P14-203	7
BSLED14-71	117	CPL24-76	107	DT8-81	111	GR900-AB	52	N600-AB	81	P14-203-81	7
BSLED14-91	117	CPL24-9	107	DTLED10-61	112	GR900-OB	52	N600-AB-O	81	P14-203-AB	7
BTLED14-1	117	CPL24-91	107	DTLED10-81	112	GR901-AB	52	N600-OB	81	P14-203-GT	7
BTLED14-51	117	CPL36-51	107	DTLED14-61	112	GR901-OB	52	N600-OB-O	81	P14-204	8
BTLED14-61	117	CPL36-52	107	DTLED14-81	112	GR902-AB	52	N600-PTR	81	P14-204-81	8
BTLED14-71	117	CPL36-61	107	DTLED24-61	112	GR902-OB	52	N600-PTR-O	81	P14-204-AB	8
BTLED14-81	117	CPL36-62	107	DTLED24-81	112	HBC-100	53	N601-AB	82	P14-212	10
C16-1	110	CPL36-7	107	DTLED36-61	112	HBC-101-BP	53	N601-OB	82	P14-231-61	10
C16-51	110	CPL36-71	107	DTLED36-81	112	HBC-101-GS	53	N601-PTR	82	P14-231-71	10
C16-52	110	CPL36-76	107	FL10-GT	30	HBC-150	53	N602-AB	83	P14-232-C71	13
C16-61	110	CPL36-9	107	FL10-MB	30	HL3-12	122	N602-OB	83	P14-233-617	6
C16-62	110	CPL36-91	107	FLX100-AB	43	HL3-18	122	N602-PTR	83	P14-233-C71	6
		CPL48-51	107	FLX100-BLK	43	HL4-12	122	N603-AB	84	P14-242-71	13

ITEM	PAGE	ITEM	PAGE	ITEM	PAGE	ITEM	PAGE	ITEM	PAGE	ITEM	PAGE
P14-246	10	RR8-1	113	SL6-9	114	T24-81	108	T9-81	108	V503-SN	90
P14-250	20	RT8-1	118	SL6-91	114	T30-1	108	TLED10-1	112	WL601-AB	92
P14-250-617	20	RT8-56	118	SL84-51	114	T30-2	108	TLED10-2	112	WL601-OB	92
P14-262	13	RT8-61	118	SL84-52	114	T30-31	108	TLED10-31	112	WL601-PB	92
P14-264	6	RWB	122	SL84-61	114	T30-5	108	TLED10-5	112	WL601-PC	92
P14-280	9	S330-52	86	SL84-62	114	T30-51	108	TLED10-51	112	WL601-SN	92
P14-280-WB	9	S330-71	86	SL84-7	114	T30-56	108	TLED10-56	112	WL602-AB	93
P14-501-52	9	S340-MB	86	SL84-71	114	T30-61	108	TLED10-61	112	WL602-SN	93
P14-501-71	9	S341-MB	86	SL84-76	114	T30-71	108	TLED10-71	112	WL604-SB	94
P14-502-52	8	SL11-51	114	SL84-9	114	T30-76	108	TLED10-76	112	WL604-SN	94
P14-D01	19	SL11-52	114	SL84-91	114	T30-81	108	TLED10-81	112	WL609-SB	98
P15-80-51	18	SL11-61	114	SLED20-52	116	T36-1	108	TLED14-1	112	WL609-SN	98
P15-80-52	18	SL11-62	114	SLED20-61	116	T36-2	108	TLED14-2	112	WL612-AB	95
P15-81-5262	18	SL11-7	114	SLED20-62	116	T36-31	108	TLED14-31	112	WL612-OB	95
P15-83-52	18	SL11-71	114	SLED20-71	116	T36-5	108	TLED14-5	112	WL612-SN	95
P15-90-52	19	SL11-76	114	SP510-52	121	T36-51	108	TLED14-51	112	WL615-OB	94
P15-90-61	19	SL11-9	114	SP510-61	121	T36-56	108	TLED14-56	112	WL615-SN	94
P16-100-627	14	SL11-91	114	SP510-7	121	T36-61	108	TLED14-61	112	WL616-AB	99
P16-101-627	14	SL16-51	114	SP510-9	121	T36-71	108	TLED14-71	112	WL616-CB	99
P16-D02-617	19	SL16-52	114	SP512-52	121	T36-76	108	TLED14-76	112	WL616-PB	99
P16-D02-627	19	SL16-61	114	SP512-61	121	T36-81	108	TLED14-81	112	WL620-CB	98
PC14-503-52	14	SL16-62	114	SP512-7	121	T4-1	108	TLED24-1	112	WL650-AB	96
PC14-503-71	14	SL16-7	114	SP512-9	121	T4-2	108	TLED24-2	112	WL650-AS	96
PF14-201	12	SL16-71	114	SP520-52	121	T42-1	108	TLED24-31	112	WL650-OB	96
PF14-250	20	SL16-76	114	SP520-61	121	T42-2	108	TLED24-5	112	WL651-AB	97
PFL-527	30	SL16-9	114	SP520-7	121	T42-31	108	TLED24-51	112	WL651-AS	97
PFL-617	30	SL16-91	114	SP520-9	121	T42-5	108	TLED24-56	112	WL651-OB	97
PH100-51-F	61	SL21-51	114	SP530-52	121	T42-51	108	TLED24-61	112	WL652-AB	97
PH100-51-J	62	SL21-52	114	SP530-61	121	T42-56	108	TLED24-71	112	WL652-AS	97
PH100-52-F	61	SL21-61	114	SP530-7	121	T42-61	108	TLED24-76	112	WL652-OB	97
PH100-52-J	62	SL21-62	114	SP530-9	121	T42-71	108	TLED24-81	112	WS12-51-F	54
PH100-61-F	61	SL21-7	114	T14-1	108	T42-76	108	TLED36-1	112	WS12-51-J	55
PH100-61-J	62	SL21-71	114	T14-2	108	T42-81	108	TLED36-2	112	WS12-52-F	54
PH100-62-F	61	SL21-76	114	T14-31	108	T4-31	108	TLED36-31	112	WS12-52-J	55
PH100-62-J	62	SL21-9	114	T14-5	108	T4-5	108	TLED36-5	112	WS12-61-F	54
PH100-71-F	61	SL21-91	114	T14-51	108	T4-51	108	TLED36-51	112	WS12-61-J	55
PH100-71-J	62	SL30-51	114	T14-56	108	T4-56	108	TLED36-56	112	WS12-71-F	54
PH100-91-F	61	SL30-52	114	T14-61	108	T4-61	108	TLED36-61	112	WS12-71-J	55
PH100-91-J	62	SL30-61	114	T14-71	108	T4-71	108	TLED36-71	112	WS12-91-F	54
PH101-51	63	SL30-62	114	T14-76	108	T4-76	108	TLED36-76	112	WS12-91-J	55
PH101-52	63	SL30-7	114	T14-81	108	T4-81	108	TLED36-81	112	WS14-2-52	58
PH101-71	63	SL30-71	114	T18-1	108	T5-1	108	UC13-32	124	WS14-2-71	58
PH101-91	63	SL30-76	114	T18-2	108	T5-2	108	UC13-61	124	WS14-2-91	58
PL16-OB	71	SL30-9	114	T18-31	108	T5-31	108	UC13-9	124	WS14-51	56
PL16-WB	71	SL30-91	114	T18-5	108	T5-5	108	UC18-32	124	WS14-52	56
PL20-OB	72	SL40-51	114	T18-51	108	T5-51	108	UC18-61	124	WS14-61	57
PL20-WB	72	SL40-52	114	T18-56	108	T5-56	108	UC18-9	124	WS14-71	57
PLED100-527	21	SL40-61	114	T18-61	108	T5-61	108	UC22-32	124	WS14-9	57
PLED100-61	21	SL40-62	114	T18-71	108	T5-71	108	UC22-61	124	WS14-91	56
PLED100-617	21	SL40-7	114	T18-76	108	T5-76	108	UC22-9	124	WS16-31	105
PLED101-527	21	SL40-71	114	T18-81	108	T5-81	108	UC28-32	124	WS16-61	105
PLED101-61	21	SL40-76	114	T21-1	108	T8-1	108	UC28-61	124	WS16-91	105
PLED101-617	21	SL40-9	114	T21-2	108	T8-2	108	UC28-9	124	WS-704	100
PLED200-527	23	SL40-91	114	T21-31	108	T8-31	108	UC34-32	124	WS-706	100
PLED200-617	23	SL64-51	114	T21-5	108	T8-5	108	UC34-61	124	WS-706-AB	100
PLED201-527	23	SL64-52	114	T21-51	108	T8-51	108	UC34-9	124	WS-706-OB	101
PLED201-617	23	SL64-61	114	T21-56	108	T8-56	108	UC45-32	124	WS-708-AB	101
PLED202-AB	24	SL64-62	114	T21-61	108	T8-61	108	UC45-61	124	WS-708-OB	101
PLED203-AB	24	SL64-7	114	T21-71	108	T8-71	108	UC45-9	124	WS750-AB	102
PLED203-PB	24	SL64-71	114	T21-76	108	T8-76	108	V500-2-AB	91	WS750-AS	102
PLED204-MB	24	SL64-76	114	T21-81	108	T8-81	108	V500-2-OB	91	WS750-OB	102
PLED300-AB	22	SL64-9	114	T24-1	108	T9-1	108	V500-2-SN	91	WS751-AB	104
PLED300-OB	22	SL64-91	114	T24-2	108	T9-2	108	V501-AB	89	WS751-AS	104
PLED300-PB	22	SL6-51	114	T24-31	108	T9-31	108	V501-OB	89	WS751-OB	104
PLED300-SN	22	SL6-52	114	T24-5	108	T9-5	108	V501-SN	89	WS752-AB	103
PS10-190-M	29	SL6-61	114	T24-51	108	T9-51	108	V502-AB	88	WS752-AS	103
RR14-1	113	SL6-62	114	T24-56	108	T9-56	108	V502-OB	88	WS752-OB	103
RR24-1	113	SL6-7	114	T24-61	108	T9-61	108	V502-SN	88	XL12-61	115
RR30-1	113	SL6-71	114	T24-71	108	T9-71	108	V503-AB	90	XL22-61	115
RR5-1	113	SL6-76	114	T24-76	108	T9-76	108	V503-OB	90		



902 Silver Ridge Road, Hyde Park, VT 05655
phone: 800-428-5367 fax: 888-881-7952

www.houseoftroy.com

House of Troy

This art for the spine is not sized.
Please adjust to fit spine.

2009