

ASSEMBLY INSTRUCTION

Item: 258-70-449 Corner Wall Mount (C)

Thank you for purchasing this quality product. Be sure to unpack carefully for small parts which may have come loose during shipment.

Read all instruction and study the drawing carefully before starting the assembly.

HARDWARE LIST				
NO	DRAWING	DESCRIPTION	SIZE	Qty
A		Allen Wrench	4 mm	1pc
B		Bolt	Ø1/4**1-1/4"	10pcs
C		Lock Washer	Ø1/4"	10pcs
D		Flat Washer	Ø1/4**19mm	10pcs
E		Screw	#8*1-1/4"	24pcs
F		Wood Screw	Ø7*5/8"	3pcs

STEP 1. Place pilaster and end panels on flat floor, and use provided Allen Wrench to assemble them with parts B,C,D

STEP 2. Use Screw E to fix connecting panel and end panels .

STEP 3. Adjust levelers to required height .

STEP 4. When connecting with other hutches, turn round the mending plate pre-screwed on top, and secure it with provided screws .

STEP 1:

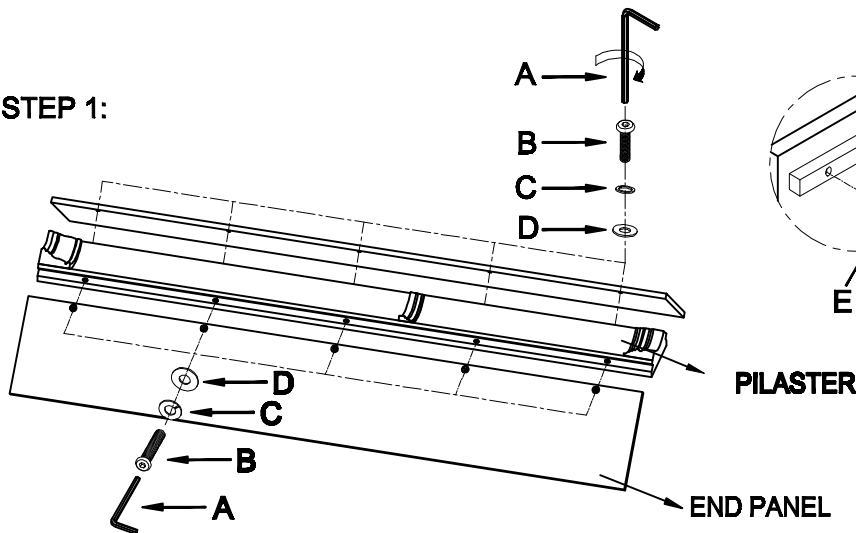

STEP 2:

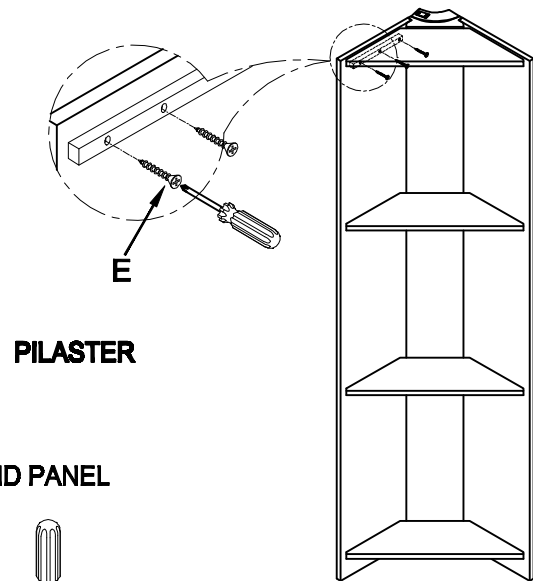

STEP 3:

