

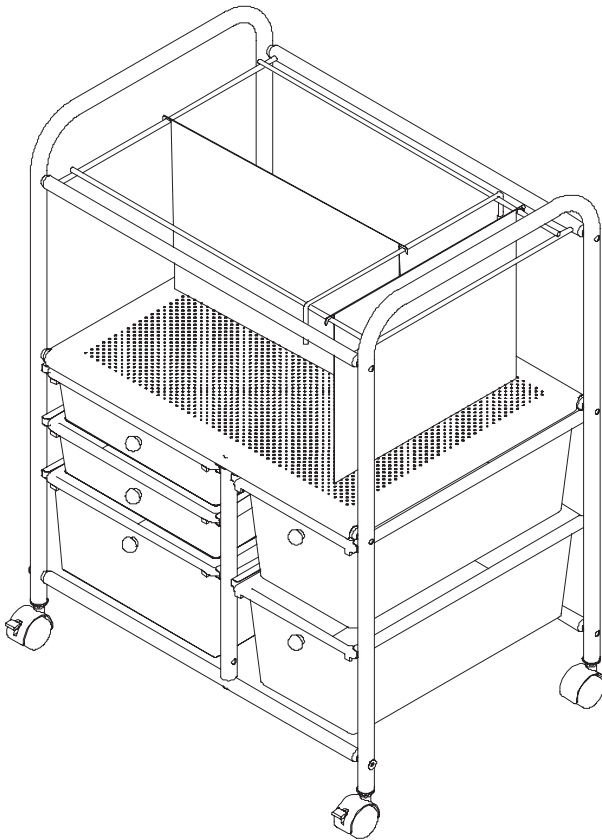

CRT-01512
CRT-W-01512

5 drawer rolling office file cart



15.25 in L x 21.5 in W x 28.75 in H (38.7 cm L x 54.6 cm W x 73 cm H)

PARTS LIST

| PART/ILLUSTRATION | (QTY) | DESCRIPTION |
|-------------------|-------|-------------|
|-------------------|-------|-------------|

| | | |
|----------|---|------------------|
| A |  | (1) side support |
|----------|---|------------------|

| | | |
|----------|---|------------------|
| B |  | (1) side support |
|----------|---|------------------|

| | | |
|----------|---|--------------------|
| C |  | (1) center divider |
|----------|---|--------------------|

| | | |
|----------|---|-----------------|
| D |  | (4) support bar |
|----------|---|-----------------|

| | | |
|----------|--|----------------|
| E |  | (1) file frame |
|----------|--|----------------|

| | | |
|----------|---|-----------|
| F |  | (1) shelf |
|----------|---|-----------|







| | | |
|----------|---|----------------|
| G |  | (16) hex screw |
|----------|---|----------------|

| | | |
|----------|---|----------------|
| H |  | (1) hex wrench |
|----------|---|----------------|

Thank you for purchasing a Honey-Can-Do office file cart!

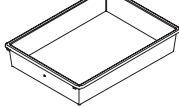
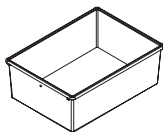
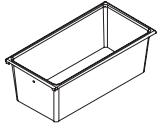
Please follow these step by step instructions carefully. Plan to spend about 35 minutes assembling your new file cart. For assistance, please contact us at info@honeycando.com or 877.2.i.Can.Do.

PARTS LIST

| PART/ILLUSTRATION | (QTY) DESCRIPTION |
|---|---|
| I  | (2) locking caster |
| J  | (2) caster |
| K  | (2) drawer |
| L  | (1) drawer |
| M  | (2) drawer |
| N  | (1) file divider bar |
| O  | (5) drawer pull |
| P  | (5) drawer pull screws <i>detail description</i> |
| Q  | (4) caster inserts |

CRT-01512 Loading Capacity

per drawer: 3.3lbs (1.5kgs)

top surface: 16.5lbs (7.5 kgs)

total unit: 33lbs (15kgs)

ASSEMBLY

STEP 1

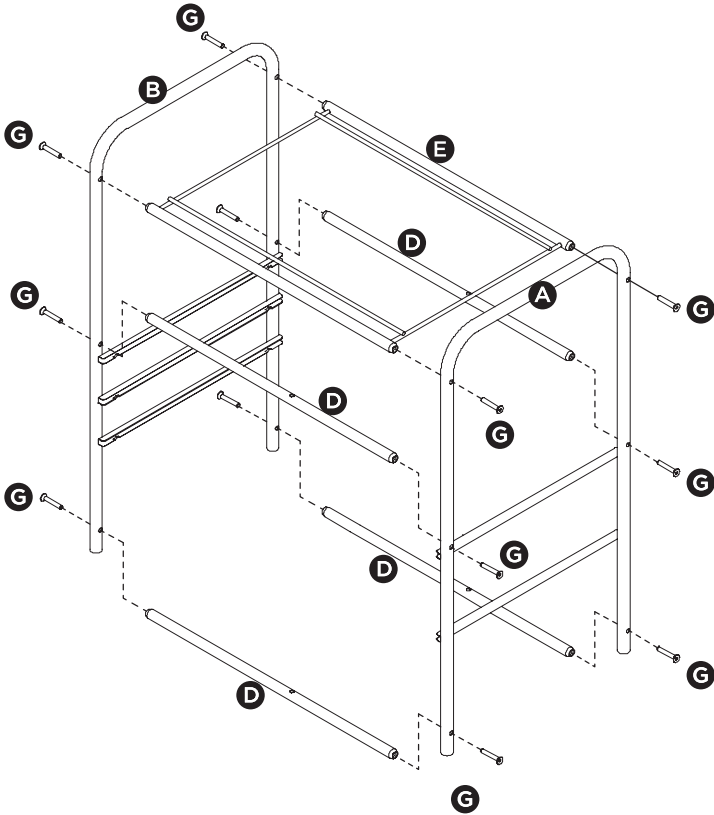

1. Using hex screws (**G**), attach support bars (**D**) to side support (**A**) and then to side support (**B**). Position the side supports so that the drawer slides are facing inward. Do not fully tighten screws yet finger tighten only.
2. Position file frame (**E**) between the side supports (**A & B**) and attach with hex screws (**G**).
3. Tighten hex screws.

ASSEMBLY

STEP 2

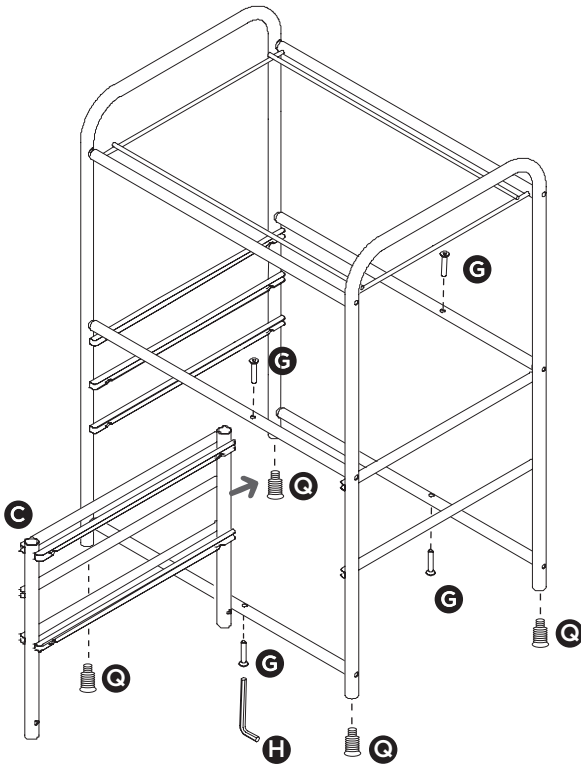

1. Position center divider (**C**) so that the drawer slides match to those on the side supports (**A & B**). Attach with 4 hex screws (**G**).
2. Tighten all hex screws (**G**) with hex wrench (**H**).
3. Firmly push caster inserts (**Q**) into bottom of side supports

ASSEMBLY

STEP 3

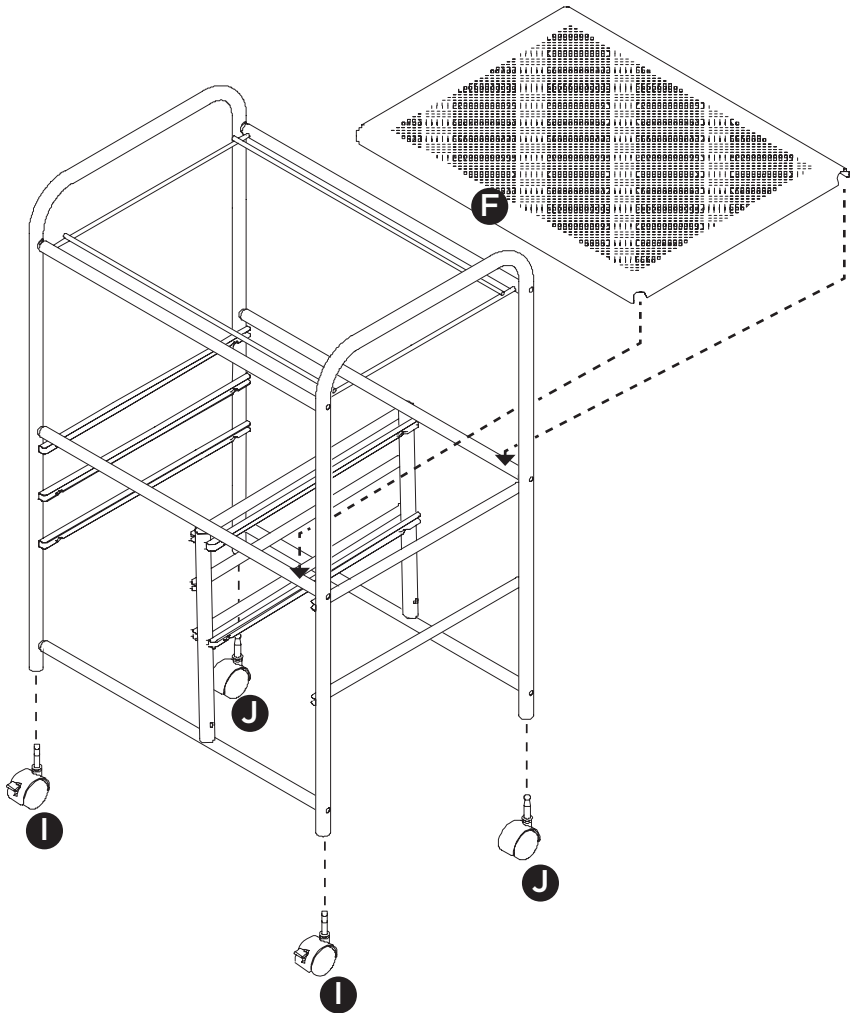

1. Lay cart on its side to install casters.
2. Install casters (**I & J**) into connectors into bottom of side supports. Ensure the casters are fully seated.
3. Place shelf (**F**) on supports are directly above drawers and clip into place.

ASSEMBLY

STEP 4

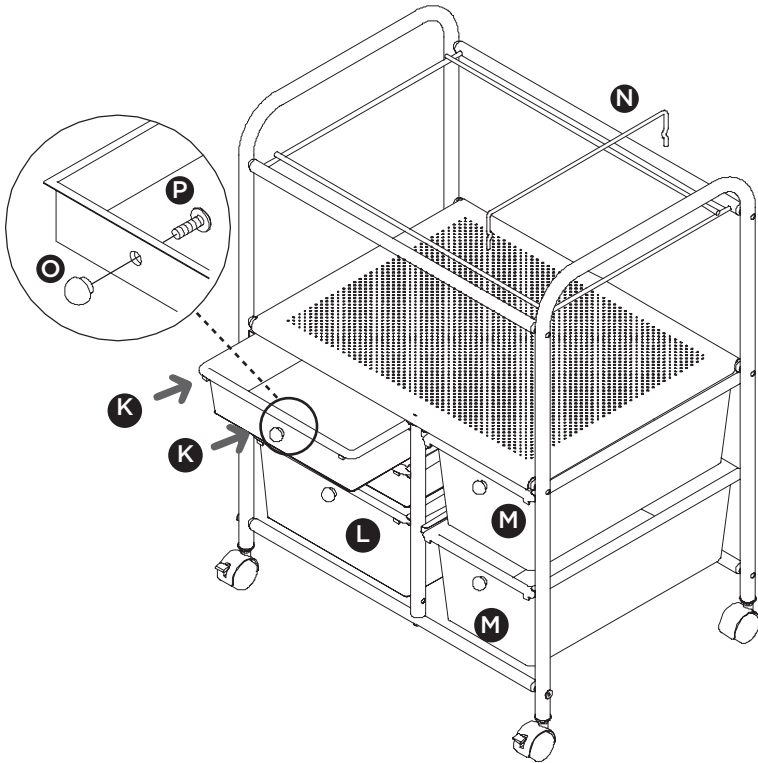

1. Using a screwdriver and the drawer pull screws (**P**) attach drawer pulls (**O**) to drawers.
2. Insert drawers into the drawer slides.
3. Place file divider (**N**) on top of file frame.
4. Enjoy your new rolling office file cart!



YOUR SOURCE FOR
ORGANIZATION,
STORAGE & STYLE

LIMITED LIFETIME WARRANTY

This product is warranted to be free of defects in material and workmanship for as long as the consumer owns the product. At Honey-Can-Do's option, defective product will be repaired, replaced or substituted with a product of equal value. For warranty service, e-mail Honey-Can-Do at warranties@honeycando.com or call at **(877) 242-2636** (Business Hours: 8a.m. to 4p.m. CST). You may also contact Honey-Can-Do at 5750 McDermott Drive, Berkeley, IL 60163. Do not dispose of the defective item until or unless you are specifically asked to do so by Honey-Can-Do as we may require return of the defective item. Honey-Can-Do shall in no event be liable for any incidental or consequential damages. Some states do not allow the exclusion or limitation of incidental or consequential damages, so the above exclusion may not apply to you. This warranty gives you specific legal rights, and you may also have additional rights, which may vary from state to state.

 PLEASE RECYCLE

121204