

Family: Lola | Item No. 5773 BN

▼ start here

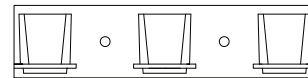

**Drawing 1 - Fixture Assembly**

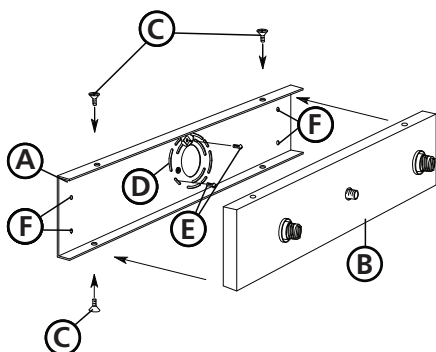

**Drawing 2 - Fixture Assembly**

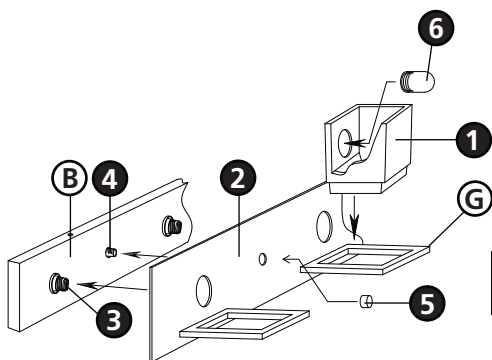

**1**

1. Find a clear area in which you can work.
2. Unpack fixture and glass from carton.
3. Carefully review instructions prior to assembly.

**\*\*\* The construction of this fixture will be accomplished by first attaching the mounting strap to the junction box, making all necessary electrical connections, mounting backplate to mounting plate, installing glass, and then attaching cage assembly.**

**2**

1. Remove main mounting plate (A) from fixture back plate (B) by removing the four flat head screws (C) - see **Drawing 1**.
2. Slide the wires from the junction box, through the large center hole, making sure curved slots (D) line up with the threaded holes in the junction box.
3. Using two 8-32 screws (E) attach the main mounting plate (A) to the junction box. A carpenter's level can be used on the folded side of mounting plate (A) to check for plumb.
4. Additional mounting holes (F) are provided on retainer plate and do to weight of fixture should be used. Use appropriate anchoring device for material to which fixture will be mounted.

**SAFETY WARNING: READ WIRING AND GROUNDING INSTRUCTIONS (I.S. 18) AND ANY ADDITIONAL DIRECTIONS. TURN POWER SUPPLY OFF DURING INSTALLATION. IF NEW WIRING IS REQUIRED, CONSULT A QUALIFIED ELECTRICIAN OR LOCAL AUTHORITIES FOR CODE REQUIREMENTS.**

**3**

Make electrical connections from supply wire to fixture lead wires. Refer to instruction sheet (I.S. 18) and follow all instructions to make all necessary wiring connections. Then refer back to this sheet to continue installation of this fixture.

**4**

1. Mount the fixture by sliding the back plate (B) over mounting plate (A) - see **Drawing 1**.
2. Attach the back plate (B) to mounting plate (A) with screws (C).

**5**

1. Glass installation is accomplished by first placing glass (1) into square metal holder (G) attached to mounting plate assembly (2) - see **Drawing 2**.
2. Carefully lift glass (1) and mounting plate assembly (2) up and slip over socket assembly (3) and center stem (4). Hold in position against backplate (B).
3. Thread barrel knob (5) onto center stem (4) and tighten to secure mounting plate and glass to fixture.
4. Fixture can now be lamped accordingly. Bulb should not be touched with fingers, use of a rag or cloth is recommended.
5. To complete assembly, slip bulb shield (6) over bulb and finger tighten shield onto socket. Over tightening could make shield difficult to remove for relamping.

Note: Maximum wattage for 5773 fixture is 60 watts per G9 bulb.

4.26.10