

HINKLEY

52" PROPEL ILLUMINATED™

INDOOR LED FAN



CEILING FAN INSTRUCTION MANUAL

WE WANT YOU TO LOVE YOUR NEW FAN

SO WE'RE HERE IF YOU HAVE A QUESTION, NEED SOME HELP OR WANT TO CHAT ABOUT OUR PRODUCTS. SEND SUGGESTIONS OUR WAY TOO—WE'RE ALWAYS LOOKING TO MAKE YOUR EXPERIENCE WITH HINKLEY A POSITIVE ONE.

> SERVICE@HINKLEY.COM

> [800.HINKLEY](tel:800.HINKLEY)

> [LET'S SEE THAT HINKLEY STYLE @HINKLEY](#)
[#HINKLEYSSTYLE](#)

This manual contains complete instructions for the installation and operation of this fan. It has been designed to make the installation process as easy as possible. If you are unfamiliar or uncomfortable with wiring, please contact a qualified electrician. If you need additional assistance or have any questions, please reach out to us.

For warranty information, visit hinkley.com.

TABLE OF CONTENTS

02	GENERAL INSTALLATION & OPERATING INSTRUCTIONS	10	ELECTRICAL CONNECTIONS
03	IMPORTANT SAFETY PRECAUTIONS	11	BLADE ATTACHMENT
03	TOOLS & MATERIALS REQUIRED	12	INSTALLATION THE SWITCH HOUSING AND LIGHT KIT
04	UNPACKING YOUR FAN	13	OPERATION
05	PREPARATION	14	CARE AND CLEANING
05	INSTALLING THE HANGING BRACKET	14	TROUBLESHOOTING
06	HANGING THE FAN	15	ENERGY GUIDE
07	INSTALLING THE FAN - HUGGER CONFIGURATION	15	SPECIFICATIONS
08	HANGING THE FAN	15	SMART BY BOND

WARNING:

Read and follow these instructions carefully and be mindful of all warnings shown throughout.

GENERAL INSTALLATION & OPERATION INSTRUCTIONS

- 1 To ensure the success of the installation, be sure to read the instructions and review the diagrams thoroughly before beginning.
- 2 To avoid possible electric shock, be sure electricity is turned off at the main power box before wiring. All electrical connections must be made in accordance with local codes, ordinances and/or the National Electric Code. If you are unfamiliar with the methods of installing electrical wiring and products, secure the services of a qualified and licensed electrician as well as someone who can check the strength of the supportive ceiling members and make the proper installation(s) and connections.
- 3 **WARNING:** To reduce the risk of fire, electric shock, or other personal injury, mount fan only on an outlet box or supporting system marked acceptable for fan support of 35 lbs (15.9 kg) or less and use mounting screws provided with the outlet box. Most outlet boxes commonly used for the support of lighting fixtures are not acceptable for fan support and may need to be replaced. Consult a qualified electrician if in doubt.
- 4 Make sure that your installation site will not allow rotating fan blades to come in contact with any object. Blades should be at least 7 feet from floor.
- 5 Blades should be attached after motor housing is hung and in place. Fan motor housing should be kept in the carton until ready to be installed to protect its finish. If you are installing more than one ceiling fan, make sure that you do not mix fan blade sets, as each blade is part of a weighted set.
- 6 After making electrical connections, spliced conductors should be turned upward and pushed carefully up into outlet box. The wires should be spread apart with the common conductor and the grounding conductor on one side of the outlet box, and the "HOT" wires on the other side.
- 7 Electrical diagrams are for reference only. Light kits that are not packed with the fan must be UL listed and should be installed per the light kit's installation instructions.
- 8 After fan is completely installed, check to make sure that all connections are secure to prevent fan from falling and/or causing damage or injury.
- 9 The fan can be made to work immediately after installation - the bearings are adequately charged with grease so that, under normal conditions, further lubrication should not be necessary for the life of the fan.
- 10 Do not operate the reverse switch while the fan blades are in motion. The fan must be turned off and the blades stopped before reversing the blades direction.

IMPORTANT SAFETY PRECAUTIONS

WARNINGS:

- Disconnect power by removing fuse or turning off circuit breaker before installing the fan and/or optional lighting.
- Support directly from building structure.
- To reduce the risk of fire, electric shock, or personal injury, mount to outlet box marked "acceptable for fan support" and use mounting screws provided with the outlet box. Most outlet boxes commonly used for the support of lighting fixtures are not acceptable for fan support and may need to be replaced. Consult a qualified electrician if in doubt.
- Do not use an incandescent light dimmer. Do not use this fan with any transformer type fan speed control device.
- To reduce the risk of personal injury, do not bend the blade arms when installing them, balancing the blades or cleaning the fan. Do not insert any objects(s) between rotating fan blades.

NOTE:

The important precautions, safeguards and instructions appearing in this manual are not meant to cover all possible conditions and situations that may occur. It must be understood that common sense, caution and carefulness are factors which cannot be built into this product. These factors must be supplied by the person(s) installing, caring for and operating the unit.

TOOLS & MATERIALS REQUIRED

- PHILLIPS SCREWDRIVER
- FLAT SCREWDRIVER
- WRENCH OR PLIERS
- WIRE CUTTER
- STEPLADDER
- WIRING SUPPLIES AS REQUIRED BY ELECTRICAL CODE

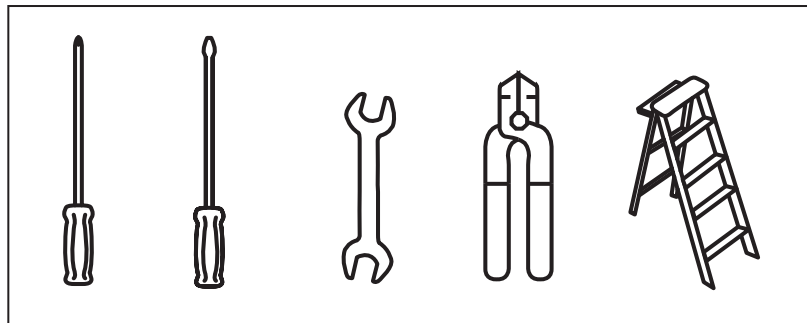

UNPACKING YOUR FAN

UNPACK YOUR FAN AND CHECK THE CONTENTS.

- Do not discard the carton. If warranty replacement or repair is ever necessary, the fan should be returned in original packing. Remove all parts and hardware. Do not lay motor housing on its side, or the decorative housing may shift, be bent or damaged.
- Examine all parts. You should have the following:

		WINDWARD PACKAGE CONTENT	
1	Blade Set of 5		
2	Hanging Bracket		
3	Canopy with Trim Ring		
4	Downrod Asm.		
5	Fan Housing with Motor *Remove rubber shipping supports around motor, if applicable. Save the screws.		
6	Blade Arm Set of 5		
7	Mounting Plate		
8	Detachable Switch Housing w/Wiring Harness		
9	Light kit		
10	Glass shade		
11	9 Watt LED Bulbs		
12	Hardware Bag		
	Pull Chain with Fob, Bracket Mounting Hardware (wood screws, screws, lock washers, washers, wire nuts), Blade to Blade Arm Screws and Fiber Washers, "S" Hook (support fan for wiring), Screws w/lock Washers - Flush Mount (3), Rubber Gasket - Flush Mount, Balance Kit		
<p>NOTE: Design of parts shown above may look slightly different for your specific model of fan.</p>			

PREPARATION

PREPARATION:

Verify you have all parts before beginning the installation. Check foam insert closely for missing parts. Remove motor from packing. To avoid damage to finish, assemble motor on soft padded surface or use the original foam inset in motor box.

DO NOT LAY MOTOR HOUSING ON ITS SIDE AS THIS COULD RESULT IN SHIFTING OF MOTOR IN DECORATIVE ENCLOSURE.

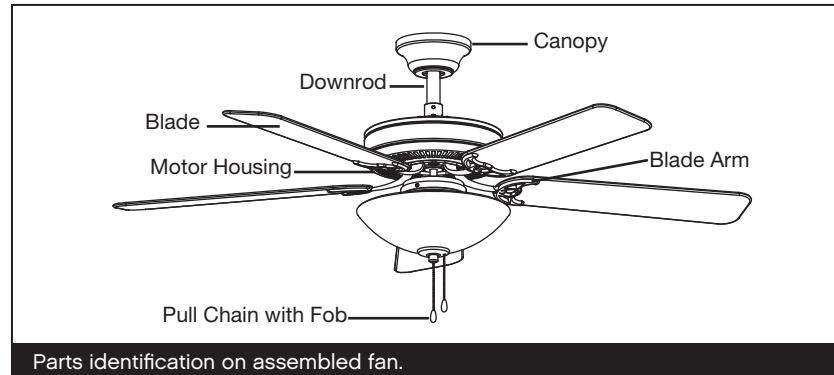

INSTALLING THE HANGING BRACKET

CAUTION: To avoid possible electrical shock, be sure electricity is turned off at the main power box before wiring. All wiring must be in accordance with National and Local Electrical Codes and the ceiling fan must be grounded as a precaution against possible electric shock.

- 1 Locate ceiling joist where fan is to be mounted, being sure location agrees with the requirements in the minimum clearance section of this guide. Wood joist must be sound and of adequate size to support 35 lbs. (See Page 1, Items 3 and 4).
- 2 If not already present, mount a UL listed outlet box marked "suitable for fan support" following the instructions provided with the outlet box. The outlet box must be able to support a minimum of 35 pounds.
- 3 Attach hanger bracket to outlet box using screws provided with the outlet box.

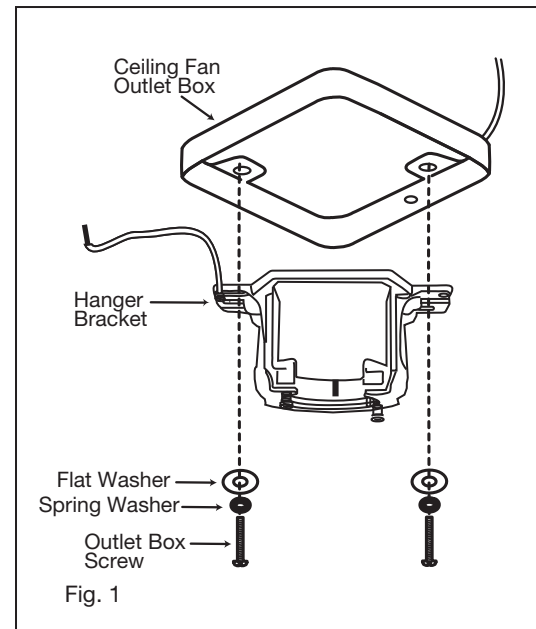

INSTALLING THE FAN

This fan has two installation options:

Both the 4.5" downrod and hugger configurations are available with your fan. Hugger configuration may be desired in a low ceiling situation. Blades will be approximately 8-10" from the ceiling.

HUGGER CONFIGURATION

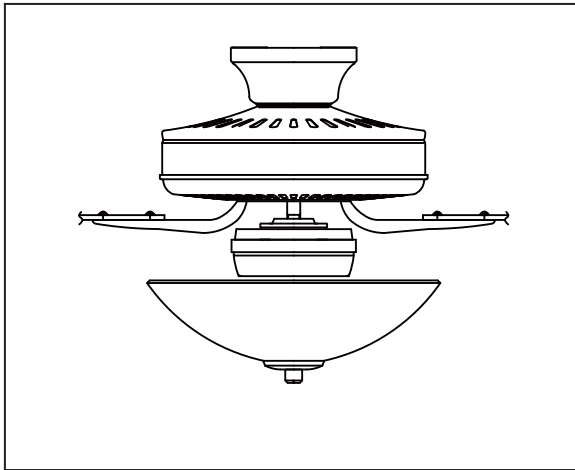

DOWNROD CONFIGURATION

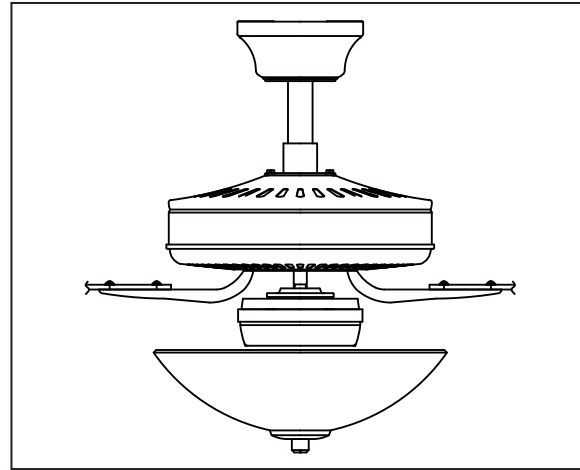

INSTALLING THE FAN - HUGGER CONFIGURATION

NOTE: The S hook is to be used for hugger style mounting.

- 1 Remove the trim ring from the canopy to expose the 6 mounting holes. The downrod, ball and cotter pin will not be used for this mounting (Fig. 1).
- 2 Feed fan wires through the rubber gasket and canopy and position the canopy over the mounting collar on top of the fan. The collar's 2 security screws will not be used and can be turned all the way into the collar to make attaching the canopy easier. (Fig. 1)
- 3 Align the canopy on top of the fan so the 3 large holes are over the 3 screws holding the collar to the fan. The 3 small holes will then be aligned with the 3 open holes in the top of the fan. (Fig. 1)
- 4 Securely attach the canopy to the top of the fan using the 3 hugger mounting screws provided.

WARNING: To avoid damaging the blade arms and blades, do not install them onto fan until fan is fastened to ceiling.

- 5 Place the S hook onto the hanger bracket. Hang the canopy (with the fan motor housing attached) from the S hook on the hanger bracket using one of the holes in the edge of the canopy (Fig. 2). This will permit you to make the electrical connections without having to hold the fan up as well.
- 6 Make the wire connections as described in "Electrical Connections" (page 9).
- 7 Insert 2 screws into the hanger bracket, leaving them partially out (Fig. 3).
- 8 Attach the canopy to the hanger bracket by inserting the keyslot openings of the canopy on the hanger bracket screws (Fig. 4), and turn the fan to the right to engage the screws in the keyslot.
- 9 Insert the 2 remaining screws through the remaining canopy holes and tighten all 4 screws.

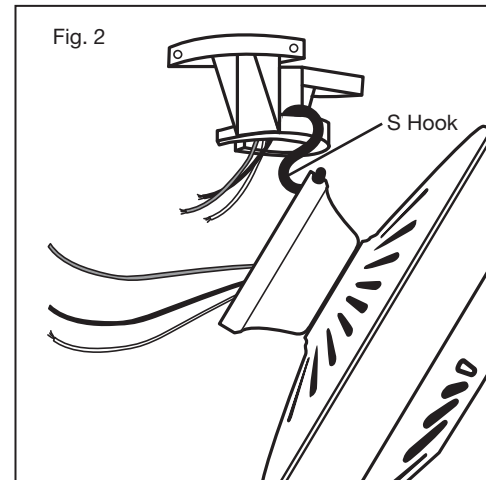
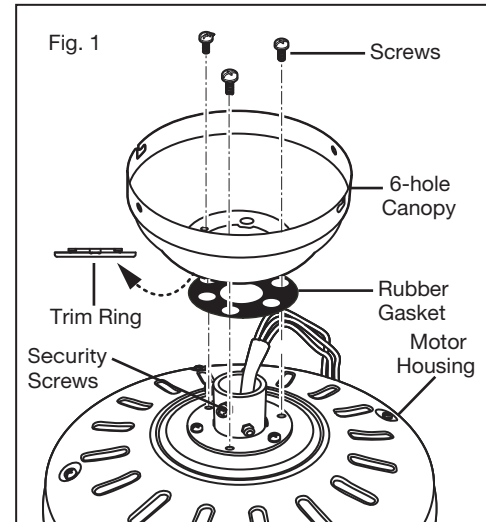
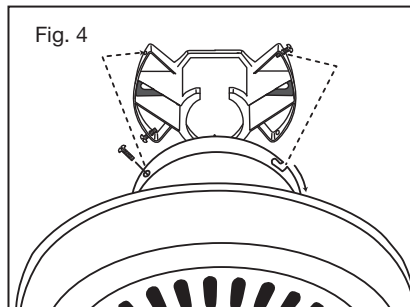
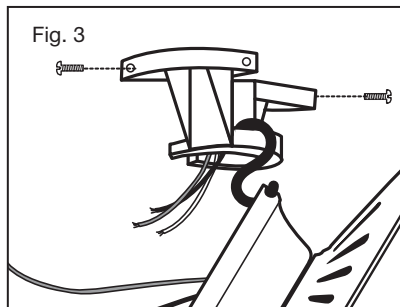

HANGING THE FAN

- 1 Remove ball from downrod by loosening set screw in the side of the ball. Slide ball down and remove ball pin; remove ball. (Fig. 1)
- 2 Carefully support fan body (motor) in its styrofoam packing with the mounting collar (where the wires come out) facing upward.
- 3 Loosen the two security set screws and remove the downrod pin and retaining clip from the coupler on top of the motor assembly. (Fig. 2)
- 4 Carefully feed the electrical lead wires from the fan through the downrod. Thread downrod into coupler until holes align. Insert downrod pin through holes in mounting collar and downrod; clip cotter pin through small hole in end of downrod pin to hold downrod in place.
- 5 Tighten security set screws against downrod using a large flat blade screwdriver to ensure a tight fit against downrod. Tighten nuts against mounting collar.

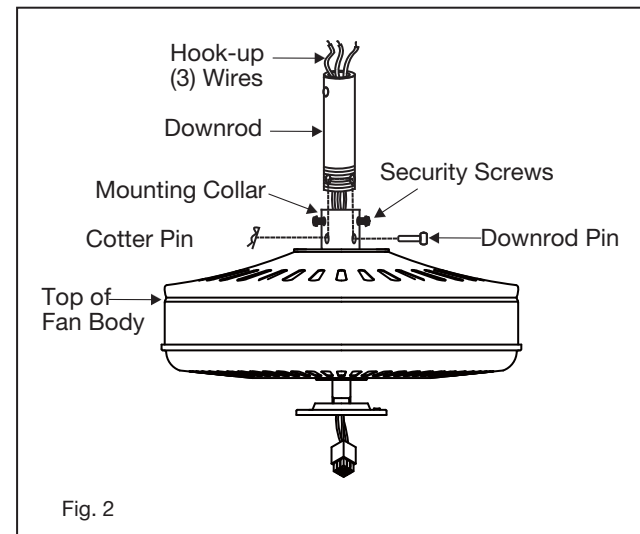
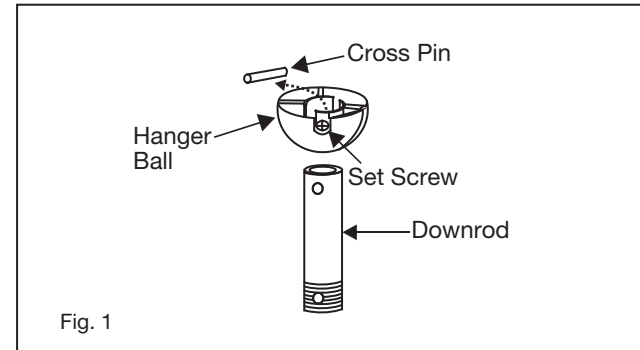

- 1 Slip canopy onto the downrod. (Fig. 3)
- 2 Thread the hanger ball onto the downrod, insert the cross pin through the downrod and tighten. Tighten the set screw.

NOTE

Fan has 6 feet of hook-up wire in case you are using a long extension downrod.

- 3 Lift ball/downrod/fan into hanger bracket opening.
NOTE: The tab opposite hanger bracket opening should fit in slot on ball. (Fig. 4)
- 4 Make wire connections, (refer to section titled "Electrical Connections").
- 5 Slide canopy up and fasten to hanger bracket with 4 screws provided.

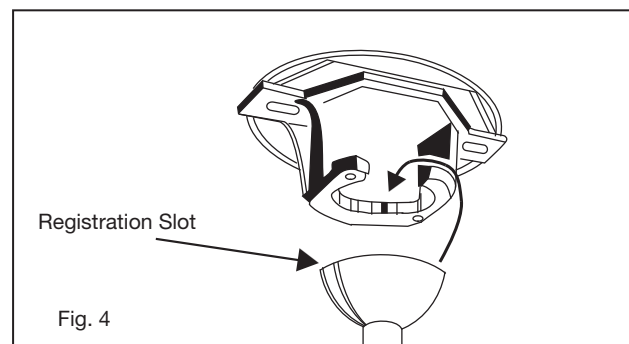
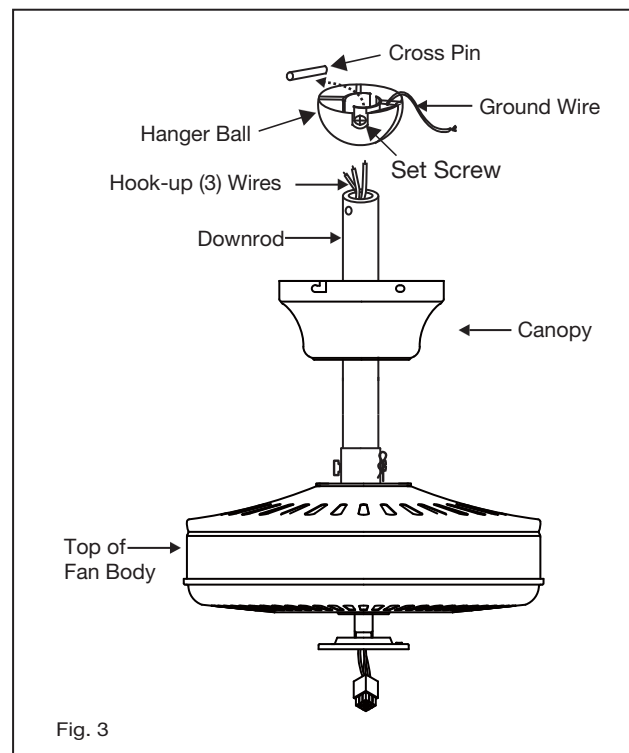

ELECTRICAL CONNECTIONS

WARNING:

To avoid possible electrical shock, be sure electricity is turned off at the main fuse or breaker box before wiring.

- 1 Connect the fan supply (black) wire to the black household supply wire as shown in Figure 1
- 2 Connect the neutral fan (white) wire to the white neutral household wire (Figure 1).
- 3 After all splices are made, check to make sure there are no loose strands. As an additional precaution we suggest to secure the plastic wire connectors to the wires with electrical tape.

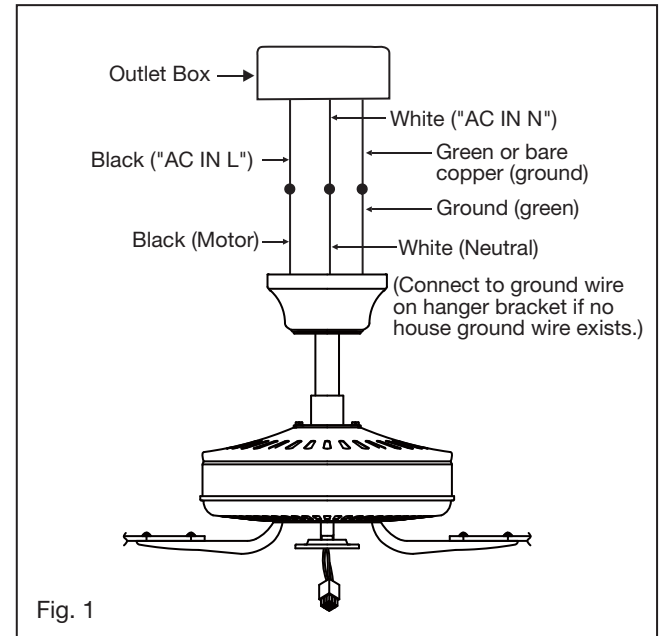

BLADE ATTACHMENT

- 1 Place fiber washer on screw. Insert this assembly through the blade and start the screw into the blade arm. Repeat this procedure without tightening the screw until all 3 screws have been started into the blade arm (Fig. 1).
- 2 Tighten each screw starting with center screw.
- 3 Fasten blade assembly to motor with provided screws and lock lockwashers. Repeat procedure for remaining blades (Fig. 2). Make sure screws are TIGHT! Loose motor screws can contribute to unnecessary hum during operation.

NOTE

Cordless power screwdrivers are **NOT** recommended, as they usually strip the heads of the screws and usually will not fully compress the lock washers on the motor screws. Use a large flat blade screwdriver for final tightening to fully compress the washers. This will help ensure proper alignment of the blades and noise-free, wobble-free running.

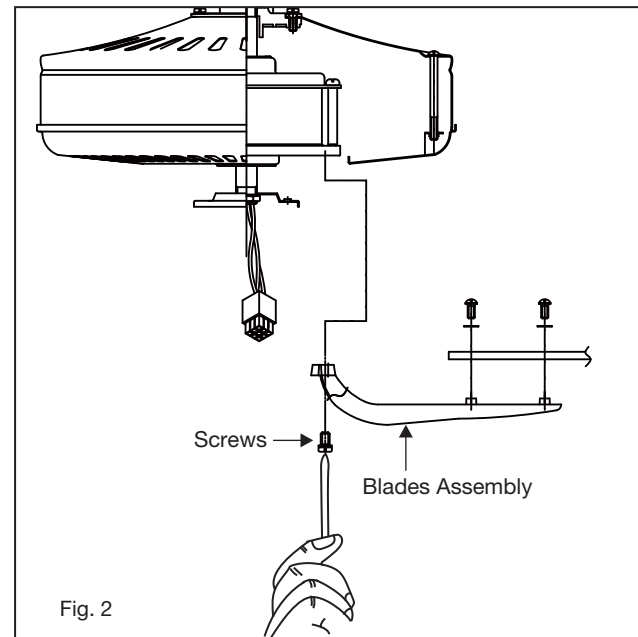
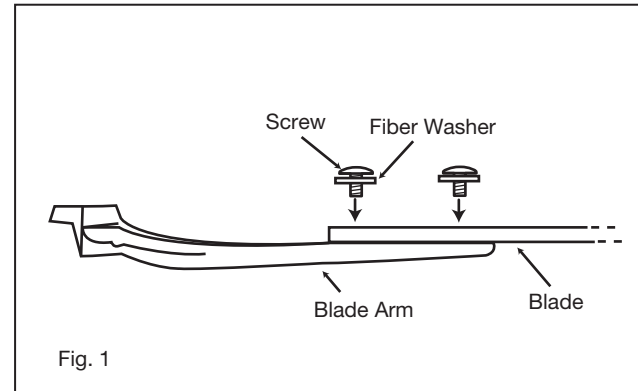

INSTALLATION THE SWITCH HOUSING AND LIGHT KIT

NOTE: Be sure the power is off before installing.

- 1 Remove and discard the plug from the switch housing, attach the light kit to the switch housing by feeding the light kit wires (black and white) through the hole of switch housing and then screw it onto the switch housing by nut & lock washer. Be sure it is tight enough to prevent light kit from vibrating loose. (Fig. 1)
- 2 While holding the light kit assembly under your fan, snap together the wire connection plugs. (Fig. 2)
- 3 Carefully push all wires back into the switch housing, then install the light kit assembly onto the mounting plate with 3 screws provided. Be sure to tighten all screws.
- 4 Install 9 Watt LED Bulbs (included). (Fig. 2)
- 5 Remove the decorative nut, glass cap, nut and rubber washer from the light kit. Place glass shade over the light kit stem, secure with the rubber washer, nut, glass cap and decorative nut. Do not overtighten. Insert the fan pull chain through the eyelet in the light kit, shade and glass cap. Also insert the light kit pull chain through the shade and nut. (Fig. 2)
- 6 Turn the power on. Your Regency Ceiling Fan is now ready to enjoy!

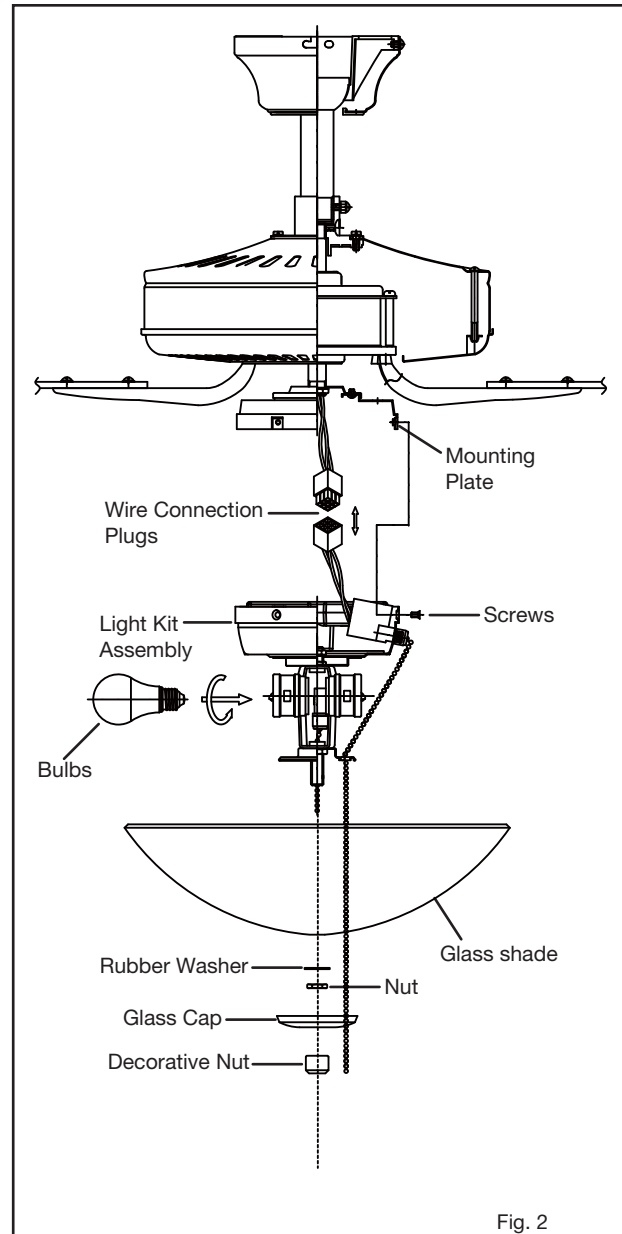
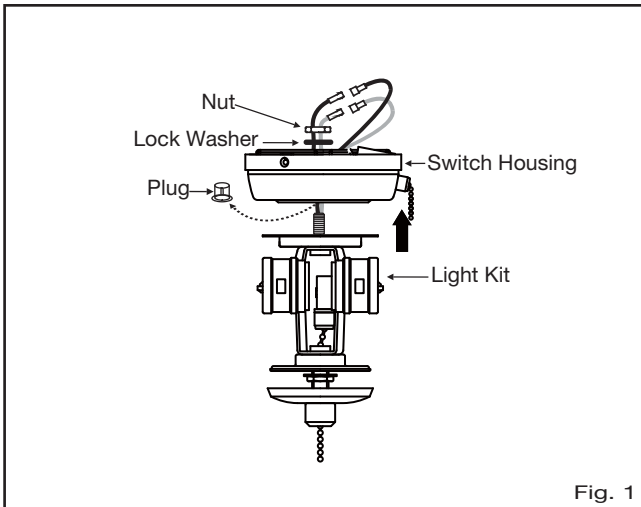

OPERATION

- 1 Turn on the power and check operation of the fan. The fan is controlled by the use of the pull chain as follows:
 - one pull = high speed
 - two pulls = medium high speed
 - three pulls = medium speed
 - four pulls = low speed
 - five pulls = off
- 2 For proper functions, ensure that the chain is pulled down fully and released each time.
NOTE: Leave pull chain switch in "high speed" position when using optional controls.
- 3 The slide switch on the side of the switch housing controls forward or reverse rotation. **Make sure switch is not stuck between forward and reverse positions.**
- 4 **IMPORTANT:** To prevent damage or cause injury, be sure that fan is switched to off and blades have stopped moving completely before attempting to change direction of rotation.

Summer Mode and Winter Mode Operation:

- 5 The reverse switch is located on the surface of the switch housing. Slide the switch to the right for summer mode operation. Slide the switch to the left for winter mode operation.
- 6 Summer Mode (forward):
A DOWNWARD airflow creates a cooling effect as shown in Figure 1. This allows you to set your air conditioner on a warmer setting without affecting your comfort.
- 7 Winter Mode (Reverse):
An UPWARD airflow moves warmer air off the ceiling area as shown in Figure 2. This allows you to set your heating unit on a cooler setting without affecting your comfort.

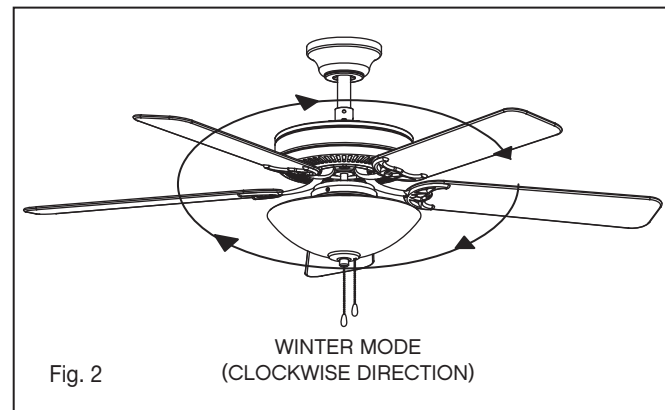
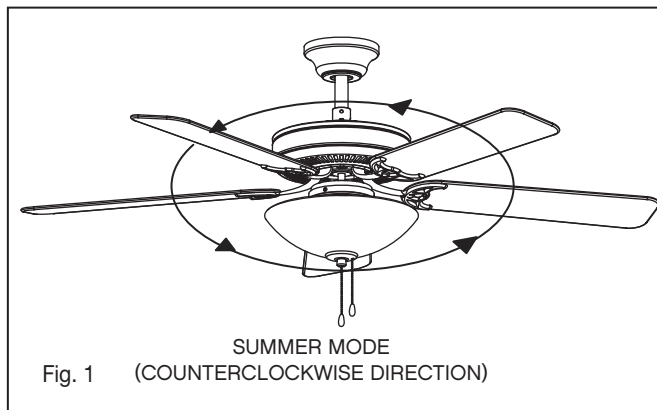

CARE AND CLEANING

Periodically it may be necessary to re-tighten blade to blade arm screws or blade arm to motor screws to prevent clicking or humming sound during operation. This is especially true in climates with broad temperature and humidity ranges.

When dusting the blades, you must support the blade to prevent bending - no pressure should be applied to the blades. If you experience any flaws in the operation of your fan, please check the following points.

TROUBLESHOOTING

CAUTION:

Switch off power supply before carrying out any of these checks.

PROBLEM	SOLUTION
FAN WILL NOT START	<ol style="list-style-type: none">1. Check main and branch circuit breakers and/or fuses.2. Check line wire connections to fan housing wiring. Make sure forward/reverse switch is set to one or the other position, not stuck in between.
FAN SOUNDS NOISY	<ol style="list-style-type: none">1. Check and make sure that all screws in motor housing are snug (but not over tight).2. Check that the screws securing blade arms to the motor are tight.3. Check that wire connectors in switch housing are not rattling against each other or the interior wall of the switch housing.4. Check that all glassware is finger tight and that bulb(s) are well held in the sockets, if a light kit is used.5. Check that the canopy is firmly attached to hanging bracket and not vibrating against ceiling.
FAN WOBBLER	<ol style="list-style-type: none">1. Check that all blades are firmly screwed into blade arms. Check that all blade arms are firmly secure to the motor.2. Check to make sure that light kit (if present) is firmly attached to switch housing and that all glassware and shades are fastened properly. Wobble can also result from even the smallest deviations in distance from blade tip to blade tip.3. If measurements from blade tip to blade tip are not equal, loosen screws connecting blade to blade arm one at a time and adjust blade(s) so that distances are equal.4. Interchanging adjacent blades may redistribute mass and result in smoother operation. Blade arms can be bent slightly to restore same pitch to all blades if a blade is different than the other blades when viewed edge on.5. Most wobble can be traced to a loose electrical box or mounting bracket. Make sure these are tight and the ball is completely seated in the bracket.6. Use the enclosed Blade Balancing Kit if the blade wobble is still noticeable.

WARNING: TO REDUCE THE RISK OF PERSONAL INJURY, DO NOT BEND THE BLADE ARM WHILE INSTALLING, BALANCING THE BLADES, OR CLEANING THE FAN. DO NOT INSERT FOREIGN OBJECTS BETWEEN ROTATING FAN BLADES.

ENERGY GUIDE

SPECIFICATIONS

AVERAGE PERFORMANCE AND ENERGY INFORMATION

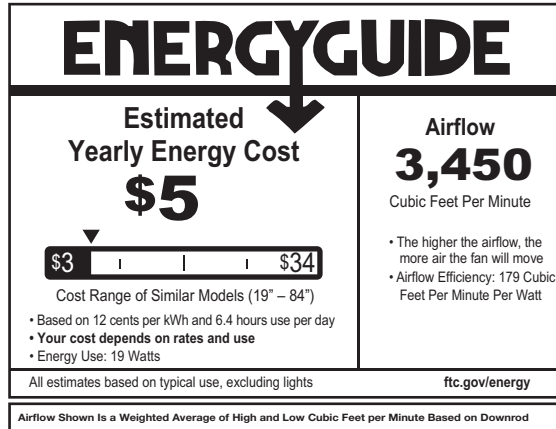

PERFORMANCE SPECIFICATIONS	STANDARD		FLUSH MOUNT	
	HIGH SPEED	LOW SPEED	HIGH SPEED	LOW SPEED
Airflow (CFM)	5192	1476	4852	1436
Energy Use (Watts)	30.1	3.6	30.2	3.5
Airflow Efficiency (CFM/W)	172	410	160	413
Energy Costs (Yearly)	\$8	\$1	\$8	\$1
Amps	0.40	0.08	0.40	0.08
RPMS	175	53	174	55

SMART BY BOND

HINKLEY SMART FAN OPTIONS:

In addition to the included wall control, you can control your Hinkley fan through the Bond app.

- To use the app, download it for free from the App Store or Google Play.
- Open the app to create your account. You can also login with your Facebook or Google account.
- Next, set up a WiFi connection. You will need the SSID and WiFi password for the network you want to connect to.
- You will receive a prompt to choose the finish of your fan and name your fan device.
- The app will walk you through the main screen and show you how to change fan speeds, dim the light, set timers or utilize breeze mode.

NOTE: Maximum of 2 fans can operate on a circuit through the wall control. Maximum of 12 fans can operate on a circuit through an on/off switch or breaker when utilizing the app for the fan control (without the wall control in the circuit).

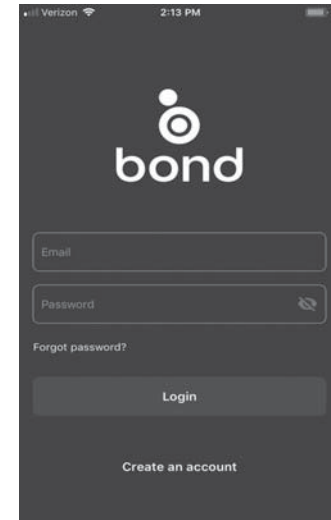

<https://bondhome.io/app>

HINKLEY IS PROUD TO PROVIDE YOU WITH CEILING FAN PRODUCTS THAT ENHANCE YOUR SPACE WITH COMFORT, PURPOSE AND STYLE. AS A FAMILY COMPANY, WE ARE COMMITTED TO DESIGN, PERFORMANCE AND QUALITY, AND WHAT'S IMPORTANT TO YOU IS PARAMOUNT TO US.

FOR A COMPLETE ASSORTMENT OF OUR PRODUCTS AND SOURCE BOOKS, VISIT HINKLEY.COM.

HINKLEY

GLOBAL HEADQUARTERS

33000 Pin Oak Parkway | Avon Lake, Ohio 44012

T (440) 653 5500 | F (440) 653 5555 | hinkley.com