

FEATURES & BENEFITS

CONSTRUCTION

Heavy-duty cast iron bowl with a glossy white enamel finish is designed for the toughest of applications, and at the same time is gentle to all users with its soft rounded corners. Unit also ships with vandal-resistant bottom plates to provide added peace of mind.

INTEGRATED TRAP

All cast brass 1-1/4" NPT adjustable traps completely concealed inside bottom plates for easy installation and lack of unwanted access.

BUBBLER HEADS

Polished chrome-plated brass bubbler heads with integral 11/16" dia. basin shank and stainless anti-rotation roll pin for vandal resistance strength. Shielded, angled stream opening provides a steady, sanitary source of drinking water at .45 gpm.

DRINKING FOUNTAIN VALVES

The push-button activated valves offer the only all stainless steel valve body that is machined out of solid bar stock, is fully serviceable through the front of the push button assembly offering access to the water control cartridge and integral water supply strainer, and with front access to the water stream height adjustment for easy maintenance without having to remove the valve. Operating pressure range of 30 to 90 psi (2.1 to 6.2 bar).

VANDAL-RESISTANT

The bubbler heads, push buttons, drain strainer and bottom plate are locked in place, discouraging unwanted vandal tampering.



OPTIONS

- Bottle Filler: Model 1920WHO, touchless bottle filler can be a stand-alone station, or mounted above Haws 1311 and 1501 series touchless drinking fountain models.
- Bottle Filler: Model 1920W bottle filler can be a stand-alone station, or mounted above Haws 1311 and 1501 series drinking fountain models.
- Remote Drinking Fountain Water chiller: Model HCR8, 8 gph (30.3 L) remote water chiller provides instantaneous cooling to meet a continuous demand for chilled water.

For more information, visit www.hawsc.com or call (888) 640-4297.

SPECIFICATIONS

Model 1430 wall mounted vandal-resistant drinking fountain shall include a white enameled-iron basin mounted with twin galvanized cast-iron wall brackets, vandal-resistant push-button operated stainless steel valves with front-accessible cartridge and flow adjustment, 100% lead-free waterways, dual polished chrome-plated brass vandal-resistant bubbler heads, polished chrome-plated brass vandal resistant waste strainer, vandal-resistant bottom plate, and chrome-plated 1-1/2" NPT trap.

APPLICATIONS

Perfect for either public or private settings, our gleaming white enameled-iron series is one of the sturdiest wall mounted fountains Haws produces. This unit is the perfect fit for high traffic areas where there is a greater need for multiple drinking stations. Elegant gloss finish and color consistency throughout the enameled-iron maintain the fountains overall appeal so it always remains looking as new as it did when it was installed. Specifically, this type of wall mounted drinking fountain may be placed in settings such as: parks, schools, and other indoor/outdoor environments where the temperature remains above freezing. Haws manufactures drinking fountains, faucets and electric water coolers to be lead-free by all known definitions including NSF/ANSI/CAN 61- Section 9, NSF/ANSI/CAN 372, California Proposition 65, and the Federal Safe Drinking Water Act. Product is compliant to California Health and Safety Code 116875 (AB 1953-2006), and NSF/ANSI/CAN 61: Q ≤ 1.





NOTES:

- ROUGH-IN DIMENSIONS MAY VARY $\pm 1/4"$ (6.4mm).
- WHEN INSTALLING THIS UNIT LOCAL, STATE OR FEDERAL CODES SHOULD BE ADHERED TO. FOR INSTALLATION HEIGHTS OTHER THAN SHOWN, DIMENSIONS MARKED (*) MUST BE ADJUSTED ACCORDINGLY.

3. REFER TO 5874 SERIES OPERATION AND MAINTENANCE MANUAL FOR PUSH BUTTON AND VALVE INSTALLATION/MAINTENANCE INSTRUCTONS.

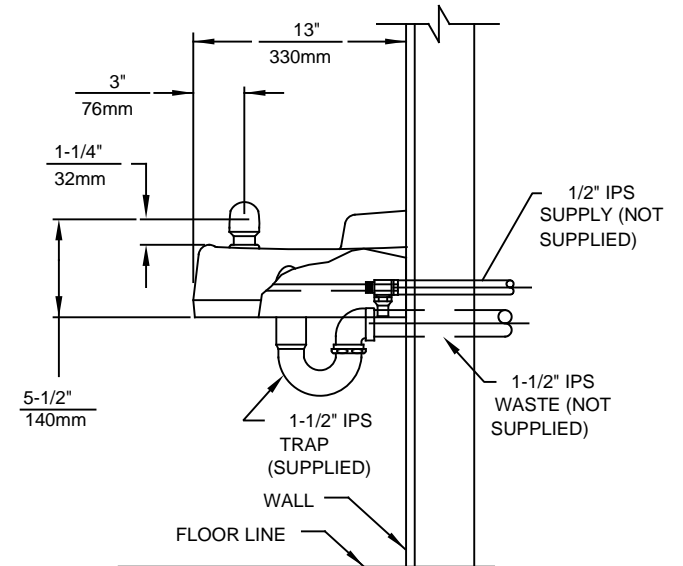
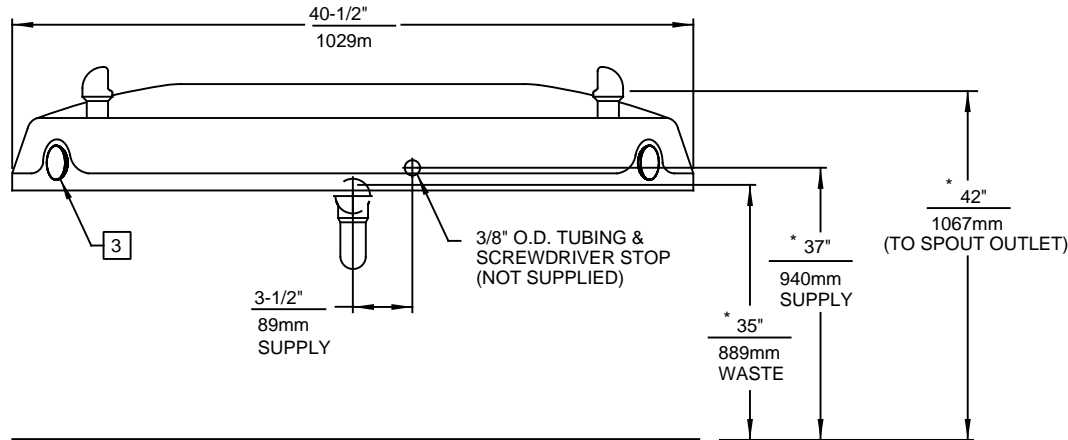
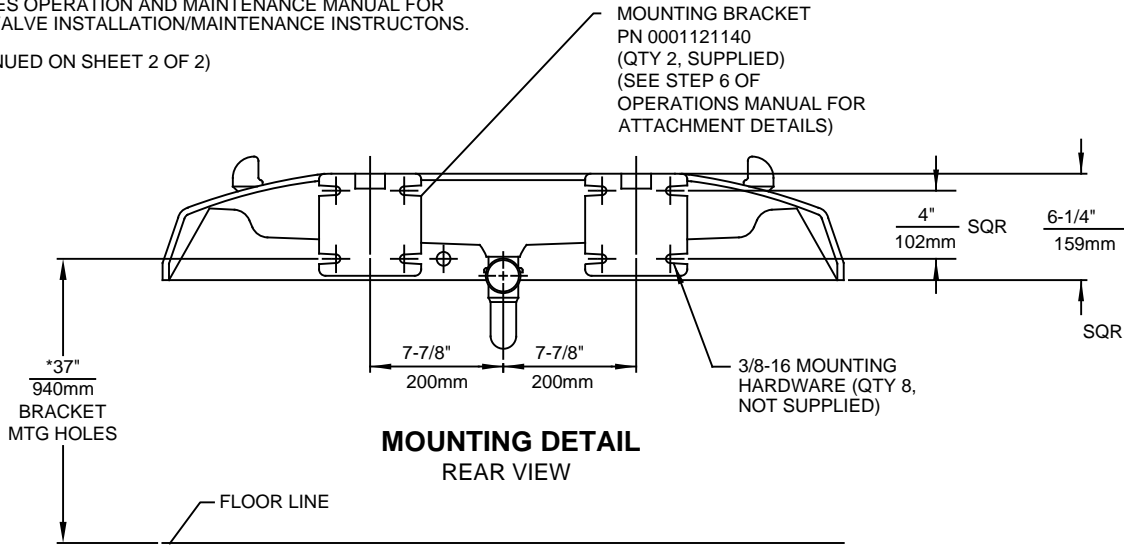
(NOTES CONTINUED ON SHEET 2 OF 2)





1455 KLEPPE LANE
SPARKS, NEVADA 89431
(775) 359-4712 FAX (775) 359-7424
E-MAIL: HAWS@HAWSO.COM
WEBSITE: WWW.HAWSO.COM

ECN NO.	REVISED PER	BY:	MODEL(S)	PART NUMBER
	ECN: 5188	JP		0002076850.D
DRAWN:	DATE:	CHKD.:	1430 TWO BUBBLER FOUNTAIN	REVISION
CJL	11-01-91	VWG		18
APPROVED:	DATE:	SCALE:	DRAWING TYPE:	SIZE:
FV	07/06/17	1:11	INSTALLATION	SHEET 1 OF 2

NOTES: (CONTINUED)

4. CONNECT WHITE "POLYPROPYLENE" TUBING ON PRESSURE SIDE (INLET) OF VALVE.
5. CONNECT CLEAR "POLYETHYLENE" TUBING ON FREE FLOW SIDE (VALVE TO BUBBLER HEAD) ONLY.

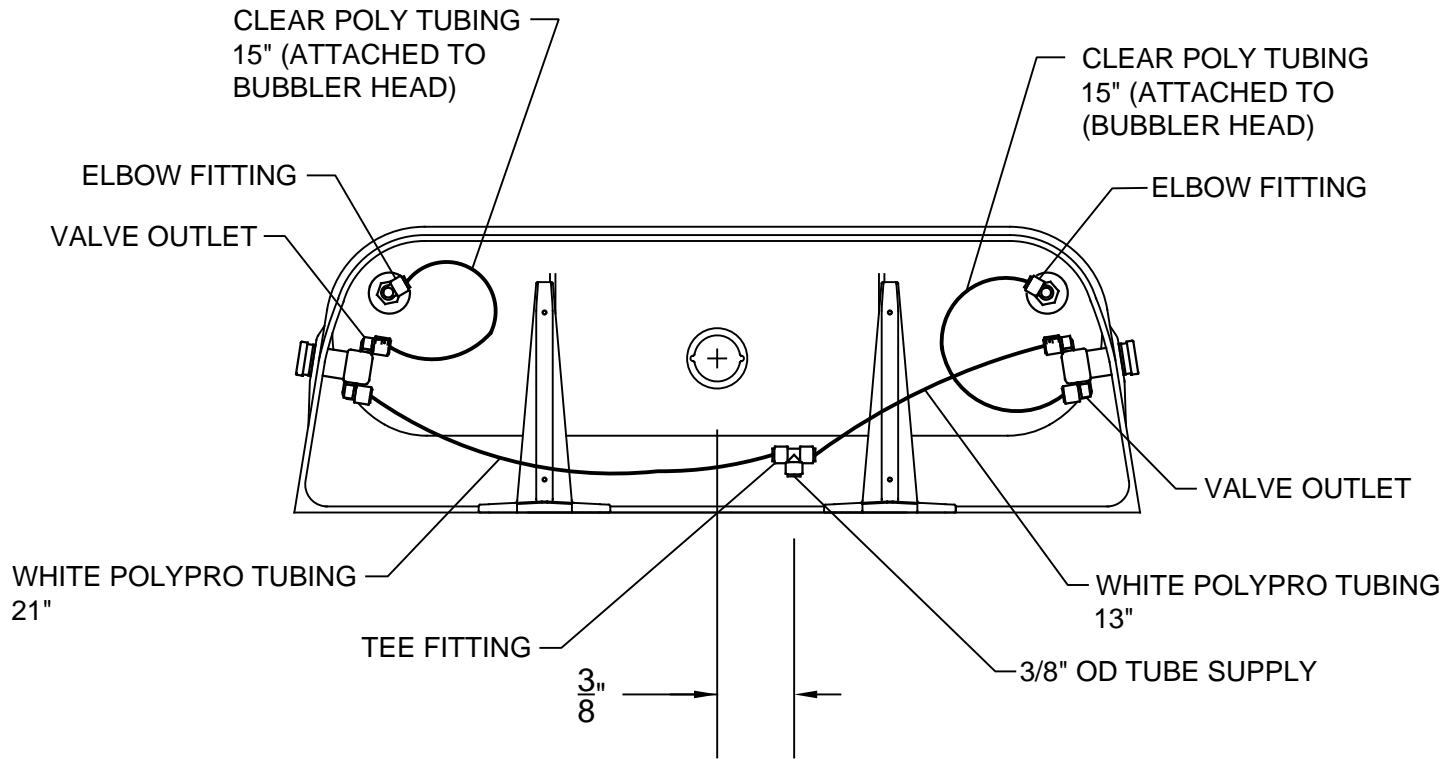

TUBING ROUTING DETAIL
BOTTOM VIEW

		1455 KLEPPE LANE SPARKS, NEVADA 89431 (775) 359-4712 FAX (775) 359-7424 E-MAIL: HAWS@HAWS.CO.COM WEBSITE: WWW.HAWS.CO.COM	
		ECN NO. REVISED PER BY: MODEL(S) ECN: 5188 JP	1430 TWO BUBBLER FOUNTAIN
DRAWN: CLJ APPROVED: FV	DATE: 11-01-91 DATE: 07/06/17	CHKD.: VWG	REVISION 18
SCALE: 1:11		DRAWING TYPE: INSTALLATION	SIZE: A SHEET 2 OF 2