

FEATURES & BENEFITS

OPTIONS

For more information, visit www.hawesco.com or call (888) 640-4297.



SPECIFICATIONS

Model PBA7 push button assembly is used with push button valve 5874, is made of polished chrome-plated brass, and includes the push button with front adjusting screw, operator, round locknut, snap ring and wave washer. This model is used on drinking fountains with front recessed push buttons and for drinking fountains with thick walls.

APPLICATIONS

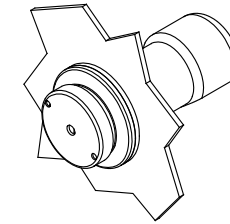
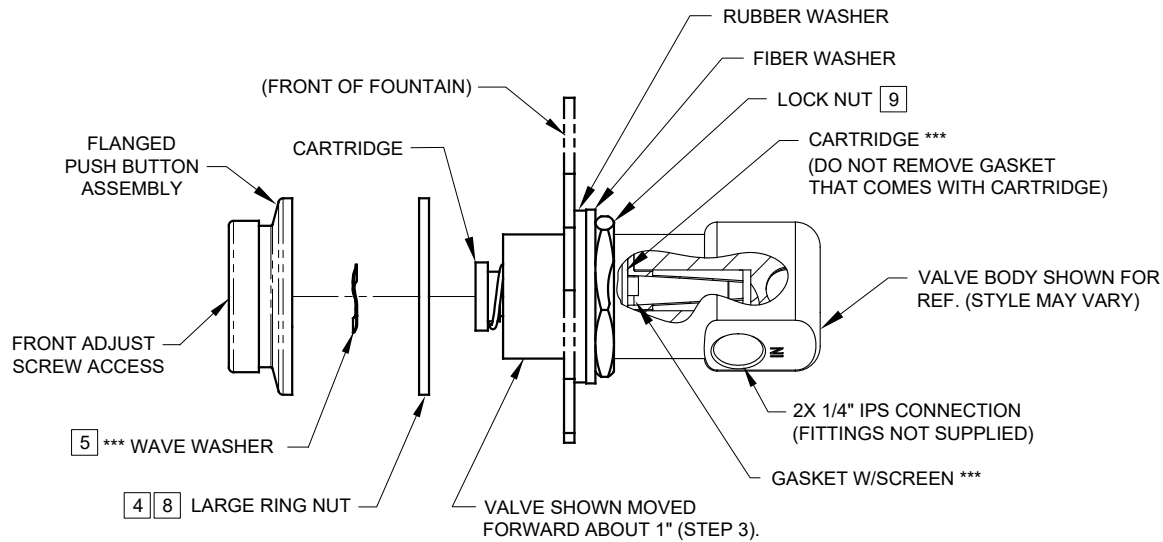

ASSEMBLED 5874PBF
(FLUSH MOUNT APPLICATION ONLY)

SEE SHEET 2 OF 2 FOR 5874PB RECESSED MOUNT INSTRUCTIONS.

*** MODEL VRK5874 & VRK5874HF- VALVE REPAIR KITS INCLUDE THESE ITEMS

INSTALLATION INSTRUCTIONS FOR 5874PBF.

- 1) FOLLOW INSTRUCTIONS CAREFULLY ON O&M MANUAL (PAGE 2 OF 6) WHEN REMOVING OLD VALVE. **NOTE: SEE PARTS BREAKDOWN (PAGE 4 OF 6) FOR ADDITIONAL NOTES.**
- 2) VERIFY THAT LOCK NUT, FIBER, AND RUBBER WASHERS ARE POSITIONED SLIGHTLY PAST MIDWAY OF THREADS ON NEW VALVE BODY.
- 3) INSERT VALVE INTO BRACKET FROM INSIDE AND PUSH FORWARD ABOUT 1".
- 4] THREAD LARGE RING NUT ONTO VALVE BODY, APPROXIMATELY 1" INTO VALVE.
- 5] PLACE WAVE WASHER INSIDE OF FLANGED PUSH BUTTON ASSEMBLY (**MUST BE IN PLACE**).
- 6] APPLY ONE (1) DOT OF LOCTITE 222MS, ON THE FEMALE THREADS OF BUTTON ASSEMBLY LEAVING THE FIRST AND LAST THREADS FREE. (FIGURE 1). **CAUTION: EXCESS LOCTITE CAN CAUSE THREADS TO LOCK VERY TIGHTLY, MAKING REPAIRS DIFFICULT.**
- **7) THREAD FLANGED PUSH BUTTON ASSEMBLY ON VALVE UNTIL WAVE WASHER MAKES SLIGHT CONTACT WITH STEM OF CARTRIDGE. **CAUTION: DO NOT HAND-TIGHTEN.**
- 8] UNTHREAD RING NUT FORWARD UNTIL IT STOPS FLUSH WITH PUSH BUTTON ASSEMBLY.
- 9] PUSH VALVE BACK TOWARD THE INSIDE OF BRACKET AND TIGHTEN LOCKNUT (SEE ILLUSTRATION ABOVE).
- 10) TIGHTEN PUSH BUTTON ASSEMBLY USING UNIVERSAL SPANNER WRENCH PROVIDED.

** OVERTIGHTENING WILL PRE-ACTUATE VALVE AND CAUSE WEEPAGE, WHILE NOT ENOUGH CONTACT BETWEEN WAVE WASHER AND STEM CAN CAUSE A LOW FLOW CONDITION.

* 6] APPLY 1 DOT OF LOCTITE 222MS (WHERE SHOWN)

* THIS ALSO APPLIES TO PBA6/PBA6C

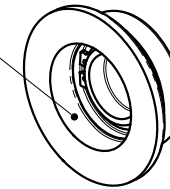
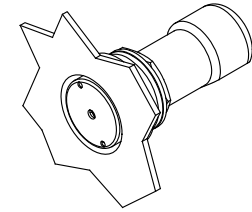
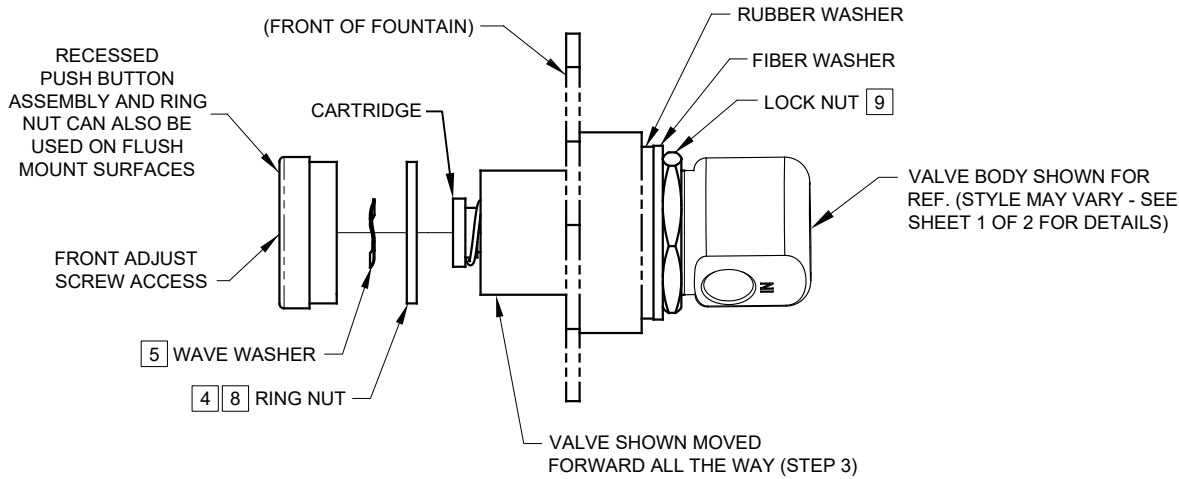

FIGURE 1

NOTE!

THIS VALVE IS PRESSURE COMPENSATING. BE SURE TO REMOVE ANY EXISTING FLOW CONTROL DEVICES. (MAY BE PRESENT IN FITTING OR SPUD).

		1455 KLEPPE LANE SPARKS, NEVADA 89431 (775) 359-4712 FAX (775) 359-7424 E-MAIL: HAWS@HAWS.CO.COM WEBSITE: WWW.HAWS.CO.COM	
ECN NO. 4250	REVISED PER ECN: 5664	BY: FV	MODEL(S)
DRAWN: LM	DATE: 06/08/16	CHK'D: JL	5874PB/5874PBF/VRK5874/VRK5874HF/ PBA6/PBA6C/PBA7/PBA7C
APPROVED: FV	DATE: 03/02/21	SCALE: NA	DRAWING TYPE: INSTALLATION
			PART NUMBER 0002077650.D
			REVISION 10
			SIZE: A SHEET 1 OF 2



ASSEMBLED 5874PB
(RECESSED MOUNT APPLICATION SHOWN)
SEE SHEET 1 OF 2 FOR FLUSH MOUNT INSTRUCTIONS.

INSTALLATION INSTRUCTIONS FOR 5874PB.

- 1) FOLLOW INSTRUCTIONS CAREFULLY ON O&M MANUAL (PAGE 2 OF 6) WHEN REMOVING OLD VALVE. **NOTE: SEE PARTS BREAKDOWN (PAGE 4 OF 6) FOR ADDITIONAL NOTES.**
 - 2) VERIFY THAT LOCK NUT, FIBER WASHER, AND RUBBER WASHERS ARE POSITIONED TOWARD BOTTOM END OF THREADS ON NEW VALVE BODY.
 - 3) INSERT VALVE INTO BRACKET FROM INSIDE, AND PUSH ALL THE WAY FORWARD (SEE ILLUSTRATION ABOVE).
 - 4) THREAD RING NUT ONTO VALVE BODY, AS FAR IN AS POSSIBLE, TOWARD FRONT OF FOUNTAIN. **NOTE: IF REPLACING A 5871 OR 5872 SERIES VALVE, YOU MAY HAVE TO CONTACT HAWS TECHNICAL SUPPORT.**
 - 5) PLACE WAVE WASHER INSIDE OF PUSH BUTTON ASSEMBLY (**MUST BE IN PLACE**).
 - 6) APPLY ONE (1) DOT OF LOCTITE 222MS, ON THE FEMALE THREADS OF BUTTON ASSEMBLY LEAVING THE FIRST AND LAST THREADS FREE. (FIGURE 1). **CAUTION: EXCESS LOCTITE CAN CAUSE THREADS TO LOCK VERY TIGHTLY, MAKING REPAIRS DIFFICULT.**
 - **7) THREAD PUSH BUTTON ASSEMBLY ON VALVE UNTIL WAVE WASHER MAKES SLIGHT CONTACT WITH STEM OF CARTRIDGE. **CAUTION: DO NOT HAND-TIGHTEN.**
 - 8) UNTHREAD RING NUT FORWARD UNTIL IT STOPS FLUSH WITH PUSH BUTTON ASSEMBLY.
 - 9) PUSH VALVE BACK TOWARD THE INSIDE OF BRACKET AND TIGHTEN LOCKNUT (SEE ILLUSTRATION ABOVE).
 - 10) TIGHTEN PUSH BUTTON ASSEMBLY USING UNIVERSAL SPANNER WRENCH PROVIDED.
- ** OVERTIGHTENING WILL PRE-ACTUATE VALVE AND CAUSE WEEPAGE, WHILE NOT ENOUGH CONTACT BETWEEN WAVE WASHER AND STEM CAN CAUSE A LOW FLOW CONDITION.

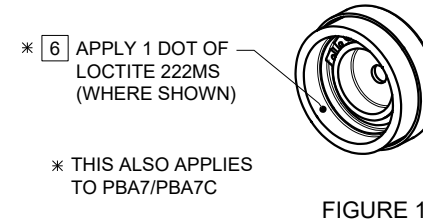

FIGURE 1

NOTE!
THIS VALVE IS PRESSURE COMPENSATING. BE SURE TO REMOVE ANY EXISTING FLOW CONTROL DEVICES. (MAY BE PRESENT IN FITTING OR SPUD).

		1455 KLEPPE LANE SPARKS, NEVADA 89431 (775) 359-4712 FAX (775) 359-7424 E-MAIL: HAWS@HAWS.CO.COM WEBSITE: WWW.HAWS.CO.COM	
ECN NO. 4250	REVISED PER ECN: 5664	BY: FV	MODEL(S) 5874PB/5874PBF/VRK5874/VRK5874HF/ PBA6/PBA6C/PBA7/PBA7C
DRAWN: LM	DATE: 08/08/16	CHK'D: JL	PART NUMBER 0002077650.D
APPROVED: FV	DATE: 03/02/21	SCALE: NA	REVISION 10
		DRAWING TYPE: INSTALLATION	SIZE: A SHEET 2 OF 2