

FEATURES & BENEFITS

BUBBLER HEAD

Polished chrome-plated brass bubbler head with integral 11/16" dia. basin shank and stainless anti-rotation roll pin for vandal resistance strength. Shielded, angled stream opening provides a steady, sanitary source of drinking water at .45 gpm.

CONSTRUCTION

One-piece stamped basin made of 14 gauge Type 304 stainless steel with a satin finish that resists stains and corrosion, with soft, rounded corners. Unit has an integral 1/4" (.6 cm) stainless steel mounting plate, vandal-resistant bottom plate, and 1-1/4" NPT trap.

DRINKING FOUNTAIN VALVE

The push-button activated valve offers the only all stainless steel valve body that is machined out of solid bar stock, is fully serviceable through the front of the push button assembly offering access to the water control cartridge and integral water supply strainer, and with front access to the water stream height adjustment for easy maintenance without having to remove the valve. Operating pressure range of 30 to 90 psi (2.1 to 6.2 bar).

VANDAL-RESISTANT

The bubbler head, push button, drain strainer and bottom plate are locked in place, discouraging unwanted vandal tampering.

INTEGRATED TRAP

All cast brass 1-1/4" NPT adjustable trap completely concealed inside bottom plate for easy installation and access.



SPECIFICATIONS

Model 1109.14 is a vandal-resistant wall mounted, barrier-free drinking fountain with 14 gauge Type 304 Stainless Steel with satin finish, vandal-resistant push-button operated stainless steel valve with front accessible cartridge, in-line strainer and flow adjustment, 100% lead-free waterways, polished chrome-plated brass bubbler head and waste strainer, integral 1/4" (.6 cm) thick stainless steel mounting plate, vandal-resistant stainless bottom plate and 1-1/4" NPT concealed all cast-brass trap.

OPTIONS

- Bottle Filler: Model 1920, bottle filler can be a stand-alone station, or mounted above Haws 1001, 1011, 1107L, 1109, 1117L, and 1119 series drinking fountain models.
- Remote Drinking Fountain Water chiller: Model HCR8, 8 gph (30.3 L) remote water chiller provides instantaneous cooling to meet a continuous demand for chilled water.
- Support Frame: Model 6800 In-wall floor mounted fixture support legs, welded steel 4-bolt floor flanges, and supplied with 'U' bolts and hardware.
- Mounting Plate: Model 6700 universal mounting plate for most wall mounted fountains.

For more information, visit www.hawsc.com or call (888) 640-4297.

APPLICATIONS

Perfect for either public or private indoor/outdoor settings, Model 1109.14 is a great fit in areas where aesthetics are important to the overall appeal of the architecture. Suitable in areas where extra durability is needed. Beautiful satin finish helps to maintain the fountains overall appeal. Specifically, this type of wall mounted drinking fountain may be placed in settings such as: schools and other locations in and around office buildings where the temperature remains above freezing. Model meets all current Federal Regulations for the disabled including those in the Americans with Disabilities Act. Haws manufactures drinking fountains, faucets and electric water coolers to be lead-free by all known definitions including NSF/ANSI/CAN 61-Section 9, NSF/ANSI/CAN 372, California Proposition 65, and the Federal Safe Drinking Water Act. Product is compliant to California Health and Safety Code 116875 (AB 1953-2006), and NSF/ANSI/CAN 61: Q ≤ 1.



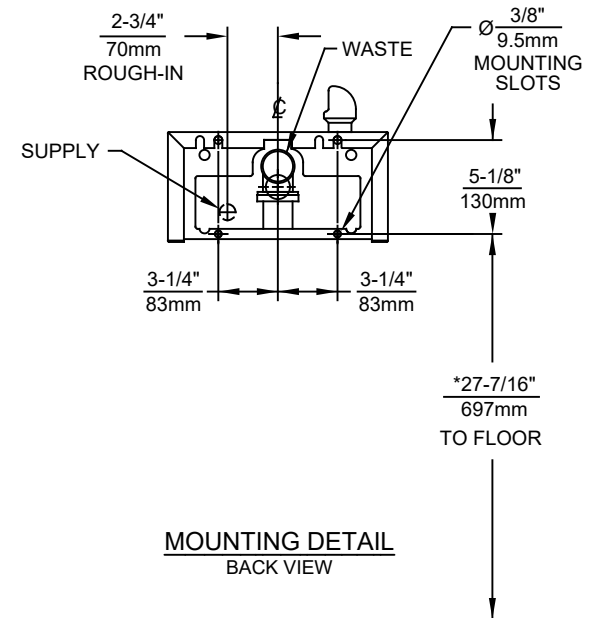
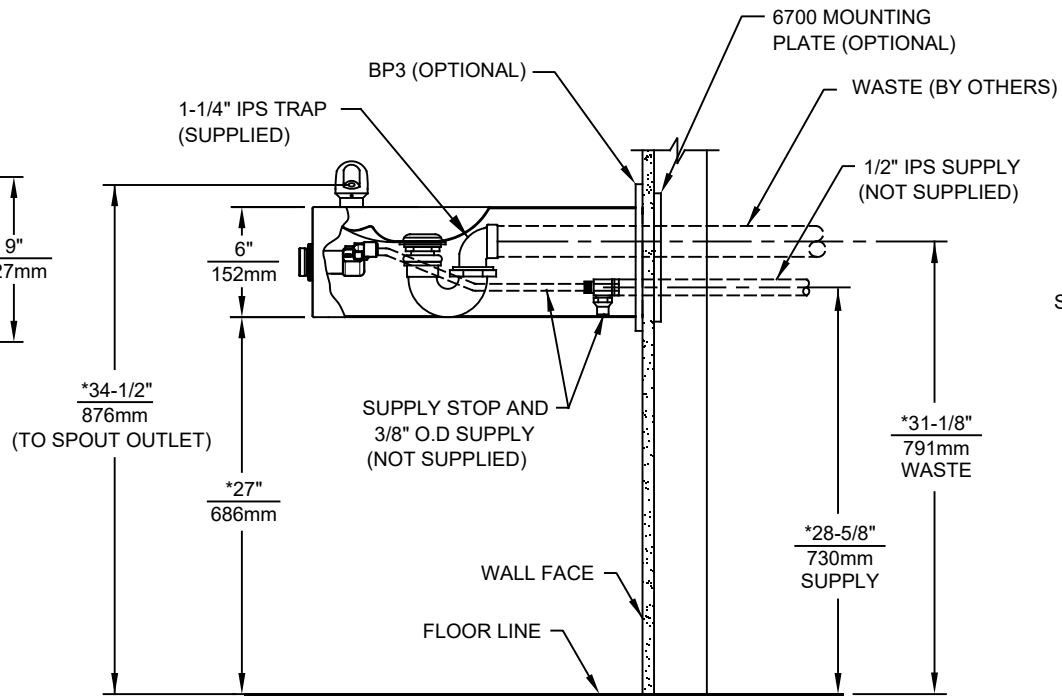
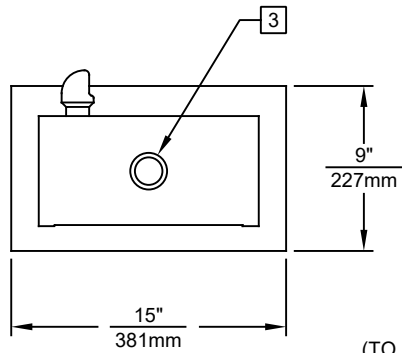
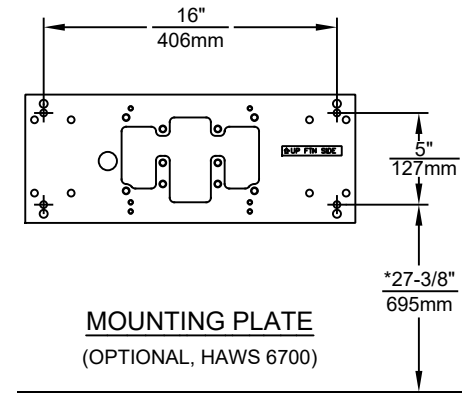
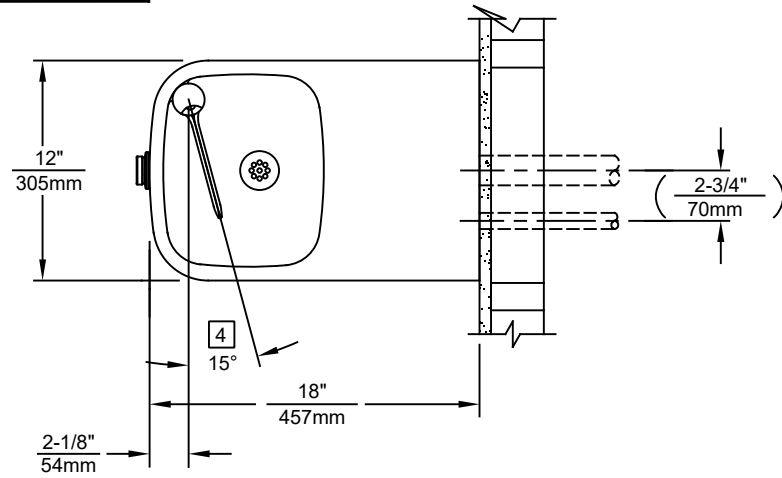

NOTES:

1. HOLD ROUGH-IN DIMENSIONS $\pm 1/4"$ (6.4mm).
2. WHEN INSTALLING THIS UNIT, LOCAL, STATE OR FEDERAL CODES SHOULD BE ADHERED TO. FOR INSTALLATION HEIGHTS OTHER THAN SHOWN, DIMENSIONS MARKED (*) MUST BE ADJUSTED ACCORDINGLY.
- 3 REFER TO 5874 SERIES/VRK5874 OPERATION AND MAINTENANCE MANUAL FOR PUSH BUTTON AND VALVE INSTALLATION AND MAINTENANCE INSTRUCTONS.
- 4 MAXIMUM ADJUSTABLE RANGE IS 15° FROM PARALLEL TO BACK OF WALL.

1455 KLEPPE LANE
SPARKS, NEVADA 89431
(775) 359-4712 FAX (775) 359-7424
E-MAIL: HAWS@HAWSCO.COM
WEBSITE: WWW.HAWSCO.COM

ECN NO. REVISED PER BY:		MODEL(S)		PART NUMBER	
ECN: 5741 FV		1109.14		0002076625.D	
DRAWN:	DATE:	CHKD.:		REVISION	
F. VASQUEZ	06/98	BJM		17	
APPROVED:	DATE:	SCALE:	DRAWING TYPE:	INSTALLATION	SHEET 1 OF 1
FV	11/12/21	NA			