

## FEATURES & BENEFITS

### CONSTRUCTION

One-piece drinking fountain with low-profile design made of 14 gauge Type 304 stainless steel with 1/4" (.6 cm) thick stainless back plate welded in, and vandal-resistant stainless bottom plate. Satin finish resists stains and corrosion.

### BUBBLER HEAD

Polished chrome-plated brass bubbler head with integral 11/16" dia. basin shank and stainless anti-rotation roll pin for vandal resistance strength. Shielded, angled stream opening provides a steady, sanitary source of drinking water at .45 gpm.

### DRINKING FOUNTAIN VALVE

The push-button activated valve offers the only all stainless steel valve body that is machined out of solid bar stock, is fully serviceable through the front of the push button assembly offering access to the water control cartridge and integral water supply strainer, and with front access to the water stream height adjustment for easy maintenance without having to remove the valve. Operating pressure range of 30 to 90 psi (2.1 to 6.2 bar).

### VANDAL RESISTANT

The bubbler head, push button, drain strainer and bottom plate are locked in place, discouraging unwanted vandal tampering.

### INTEGRATED TRAP

All cast brass 1-1/4" NPT adjustable trap completely concealed inside bottom plate for easy installation and access.

### QUALITY CONTROL

Pre-built fountain is pressure tested to ensure no leaks and proper functionality.

## OPTIONS

- Bottle Filler: Model 1920, bottle filler can be a stand-alone station, or mounted above Haws 1107L series drinking fountain models.
- Bottle Filler Stand: Model BTL1107, add-on stainless steel stand to place bottle on when 1920 bottle filler is used.
- Water Filter: Model 6426, 10" x 2" (25.4 x 5.1 cm), in-line lead removal element that reduces lead from incoming water supply.

For more information, visit [www.hawsco.com](http://www.hawsco.com) or call (888) 640-4297.



## SPECIFICATIONS

Model H1107.8 ADA electric wall mounted vandal-resistant water cooler shall include a 14 gauge Type 304 Stainless Steel satin finish basin, vandal-resistant push-button operated stainless steel valve with front-accessible cartridge and flow adjustment, 100%lead-free waterways, polished chrome-plated brass vandal-resistant bubbler head, and a polished chrome-plated brass vandal-resistant waste strainer. Unit shall also include a vandal-resistant bottom plate, satin stainless steel back panel and louvered intrusion-proof grill, and 1-1/4" NPT trap. Unit can be mounted to meet ADA or Child ADA specifications. The R-134a refrigeration system is hermetically sealed and delivers a minimum of 8 gph (30.3 L) of water at 50° F (10° C) cooled from 80° F (26.7° C) inlet water at 90° F (32.2° C) ambient. 115 Volts, 60Hz, rated watts: 370, full load amps: 5.

**REQUIRES MODEL HCR8 AND MTGFR.7 PRICED SEPARATELY.**

## APPLICATIONS

Specifically, this type fountain may be placed in settings such as: schools, office buildings, shopping malls, and other indoor environments. Electric water coolers are not recommended or designed for outdoor applications or enclosed pool areas (chlorine). These conditions may void warranty. Model meets all current Federal Regulations for the disabled including those in the Americans with Disabilities Act. Haws manufactures drinking fountains, faucets and electric water coolers to be lead-free by all known definitions including NSF/ANSI/CAN 61-Section 9, NSF/ANSI/CAN 372, California Proposition 65, and the Federal Safe Drinking Water Act. Product is compliant to California Health and Safety Code 116875 (AB 1953-2006), and NSF/ANSI/CAN 61: Q ≤ 1. Haws electric water coolers comply with ARI Standard 1010 and ANSI A117.1, and are listed by Underwriter Laboratories to U.S. and Canadian standards.



**NOTES:**

1. HOLD ROUGH-IN DIMENSIONS ± 1/8" (3.2mm)
2. WHEN INSTALLING THIS UNIT, LOCAL, STATE, OR FEDERAL CODES SHOULD BE ADHERED TO. FOR INSTALLATION HEIGHTS OTHER THAN SHOWN, DIMENSIONS MARKED (\*) MUST BE ADJUSTED ACCORDINGLY.
3. REFER TO 5874 SERIES OPERATION AND MAINTENANCE MANUAL FOR PUSH BUTTON AND VALVE INSTALLATION/MAINTENANCE INSTRUCTIONS.
4. REFER TO MTGFR.7 INSTALLATION DRAWING FOR FRAME ROUGH-IN DIMENSIONS.
5. INSERT 5/16"-18 PANEL NUT RETAINERS FROM OPPOSITE SIDE AT LOCATIONS SHOWN.
6. FOUNTAIN REMOVAL: FIRST REMOVE SCREWS AND THEN SQUEEZE CLIPS ON NUT RETAINER TO POP OUT. INSTALL IS REVERSE OF REMOVAL.
7. ALIGN HOLES IN CHILLER SUPPORT TRAY WITH HOLES IN FRAME AND FASTEN WITH #10 SHEET METAL SCREWS.
8. ROUGH-IN DIMENSIONS FOR FOUNTAIN HEIGHTS:

CHILD WHEELCHAIR HEIGHT:  
 WASTE: 26-1/4" (667mm)  
 SUPPLY: 26-1/8" (664mm)  
 FOUNTAIN: 24" (610mm)  
 BUBBLER: 29-7/8" (756mm)  
 FRAME: 3-1/8" (79mm)

ADULT WHEELCHAIR HEIGHT:  
 WASTE: 29-1/4" (743mm)  
 SUPPLY: 29-1/8" (740mm)  
 FOUNTAIN: 27" (686mm)  
 BUBBLER: 32-7/8" (832mm)  
 FRAME: 6-1/8" (156mm)

ADULT STANDING HEIGHT:  
 WASTE: 34-3/4" (883mm)  
 SUPPLY: 34-5/8" (879mm)  
 FOUNTAIN: 32-1/2" (826mm)  
 BUBBLER: 39-3/8" (972mm)  
 FRAME: 11-5/8" (384mm)

**IMPORTANT: MOUNTING FRAME MUST BE INSTALLED SO THAT LIP OF FRAME SITS AGAINST FINISHED WALL FACE.**

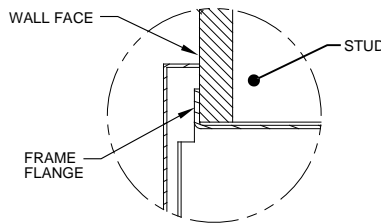

**DETAIL A**

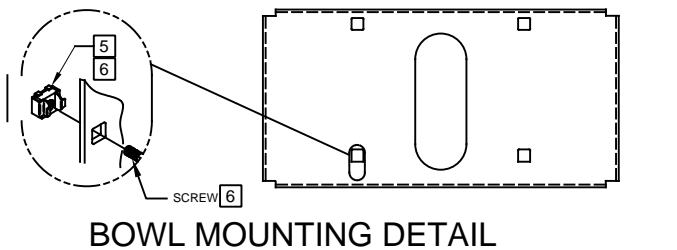
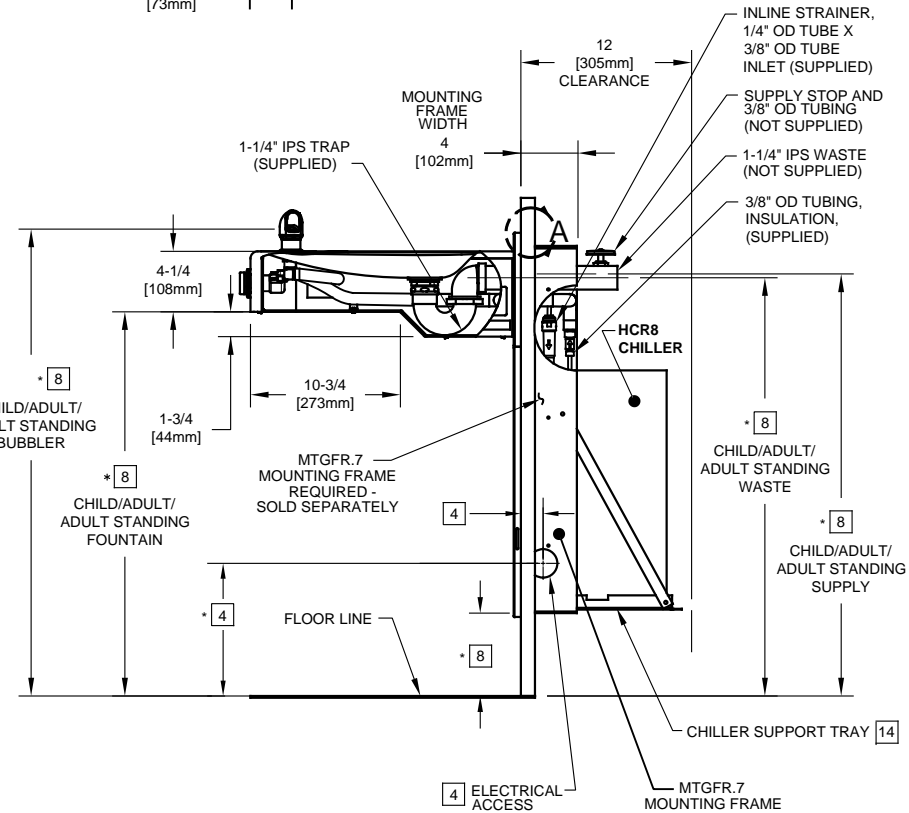
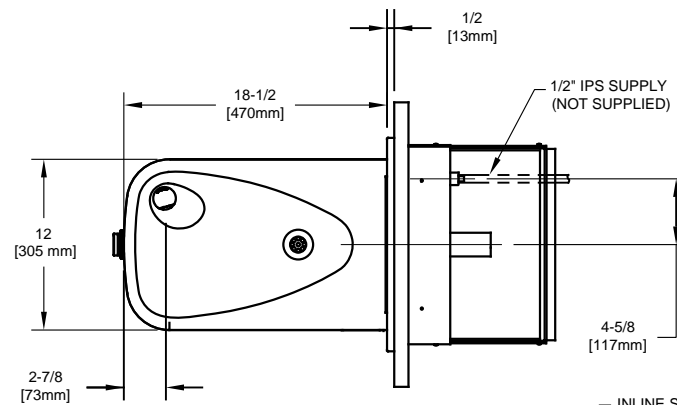
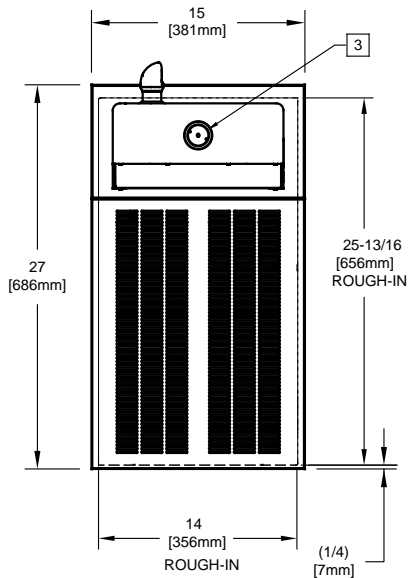

1455 KLEPPE LANE  
 SPARKS, NEVADA 89431  
 (775) 359-4712 FAX (775) 359-7424  
 E-MAIL: HAWS@HAWSCO.COM  
 WEBSITE: WWW.HAWSCO.COM

ECN NO.	REVISED PER	BY:	MODEL(S)	PART NUMBER
	ECN: 5545	FV		0002080221.D
DRAWN:	DATE:	CHKD.:	H1107.8	REVISION
C.FENNER	12-19-06	DP		15
APPROVED:	DATE:	SCALE:	DRAWING TYPE:	SHEET 1 OF 1
FV	06/26/20	N/A	INSTALLATION	