

**NOTES:**

1. HOLD ROUGH-IN DIMENSIONS ± 1/8" (3.2mm).
2. WHEN INSTALLING THIS UNIT, LOCAL, STATE, OR FEDERAL CODES SHOULD BE ADHERED TO FOR INSTALLATION DIMENSIONS (LOCATIONS), WASTE AND SUPPLY REQUIREMENTS OTHER THAN SHOWN.
3. \*\* INSTALLER MUST PROVIDE TRAP FOR PROPER INSTALLATION.

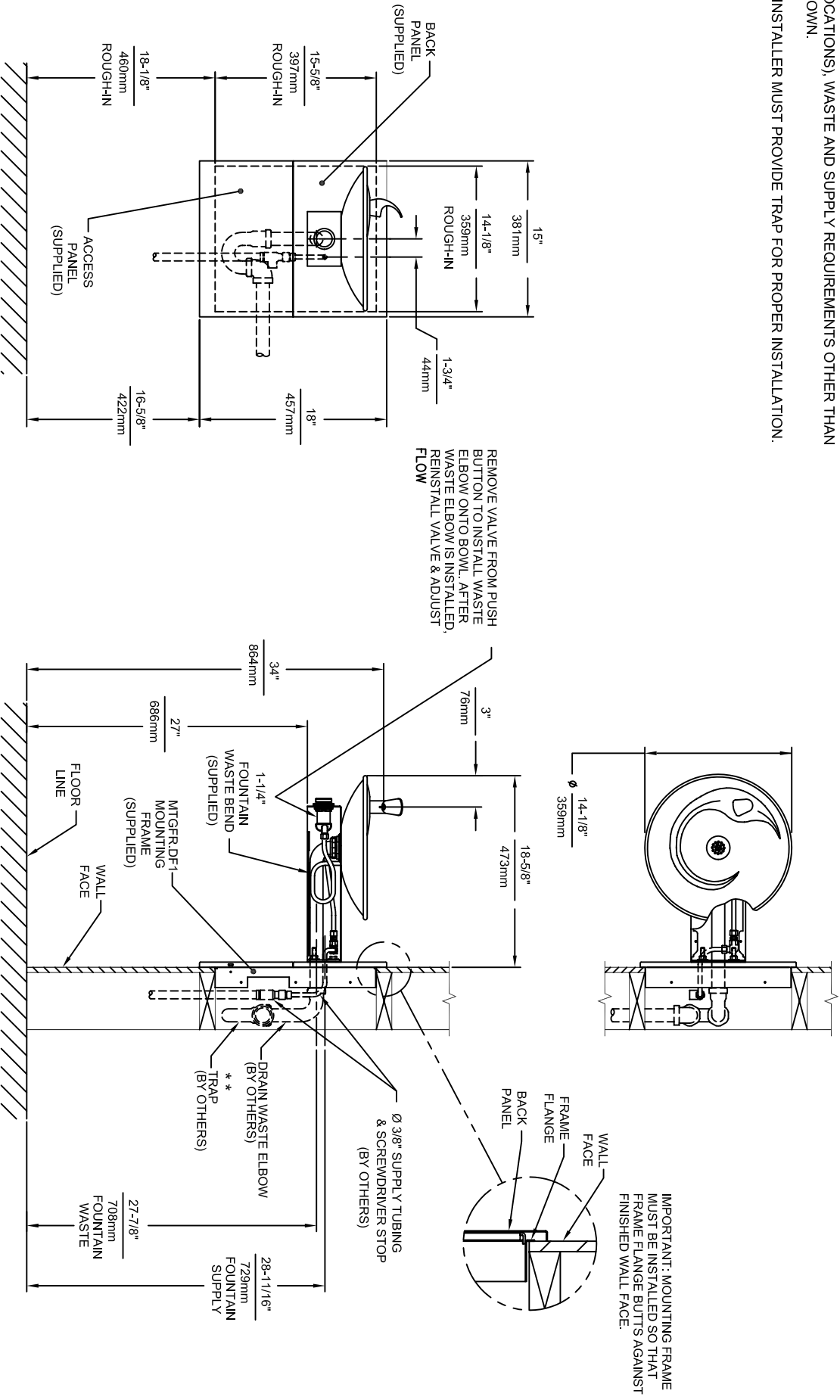

**Haws** corporation

INFO FAX : 1-888-FAX-HAWS (1-888-329-4297)  
 1455 Kieppe Ln, Sparks, NY, 89431  
 Phone: 775-359-4712 Fax: 775-359-7424  
 Haws Ag, Bachweg 3, CH-3401 Burgdorf, Switzerland  
 Haws Mfg Pte Ltd, 74 Sungei Kadut Loop, Singapore 729531  
 e-mail: haws@haws.co.com Website: www.haws.co.com

FORM NO.	REVISED FROM	DATE	MODEL(S)
CON: 3512	LF	8/02/99	1001MS/1001HPSMS
DATE	CHG:		
APPROVED	DATE	SCALE: 1:14	DRAWING TYPE: INSTALLATION/REWORK
INFO FAX DOC # 2100167/2100147767			
0002076510.D			
DRAWING NUMBER:			
14221A00			
REV:			
4			
SIZE: A	SHT: 1	OF: 1	