



model **8317LT**  
Area Light

## FEATURES & BENEFITS

---

## OPTIONS

---

For more information, visit [www.hawesco.com](http://www.hawesco.com) or call (888) 640-4297.



## SPECIFICATIONS

---

Model 8317LT is a vapor tight and gasketed green light for continuous illumination of the 8317CTFP series showers. Model is CSA electrical certified, TYPE 4. For Class 1, Div. 2, Group B, C & D. Temperature Code: T2C; only when used with 8317CTFP.

## APPLICATIONS

---

Model is CSA electrical certified, TYPE 4. For Class 1, Div. 2, Group B, C & D. Temperature Code: T2C; only when used with 8317CTFP.



**NOTES:**

1. INSTALLER MUST USE SUFFICIENT THREAD SEALANT, SUCH AS APPLETON TLC-3, RECOMMENDED FOR USE IN HAZARDOUS LOCATIONS, TO ENSURE A WATERTIGHT SEAL ON ALL ELECTRICAL NPT CONNECTIONS.

(CONTINUED ON SHEET 2)

**SEE WARNINGS ON SHEET 2**

INCOMING POWER TO TOP PORT OF JUNCTION BOX (NOT SUPPLIED)

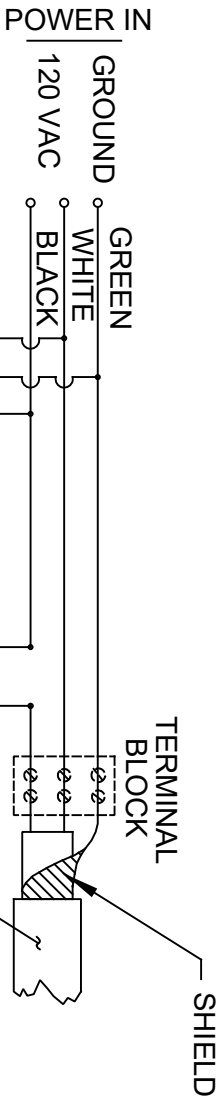

**8317LT (LIGHT KIT INSTALLATION)**

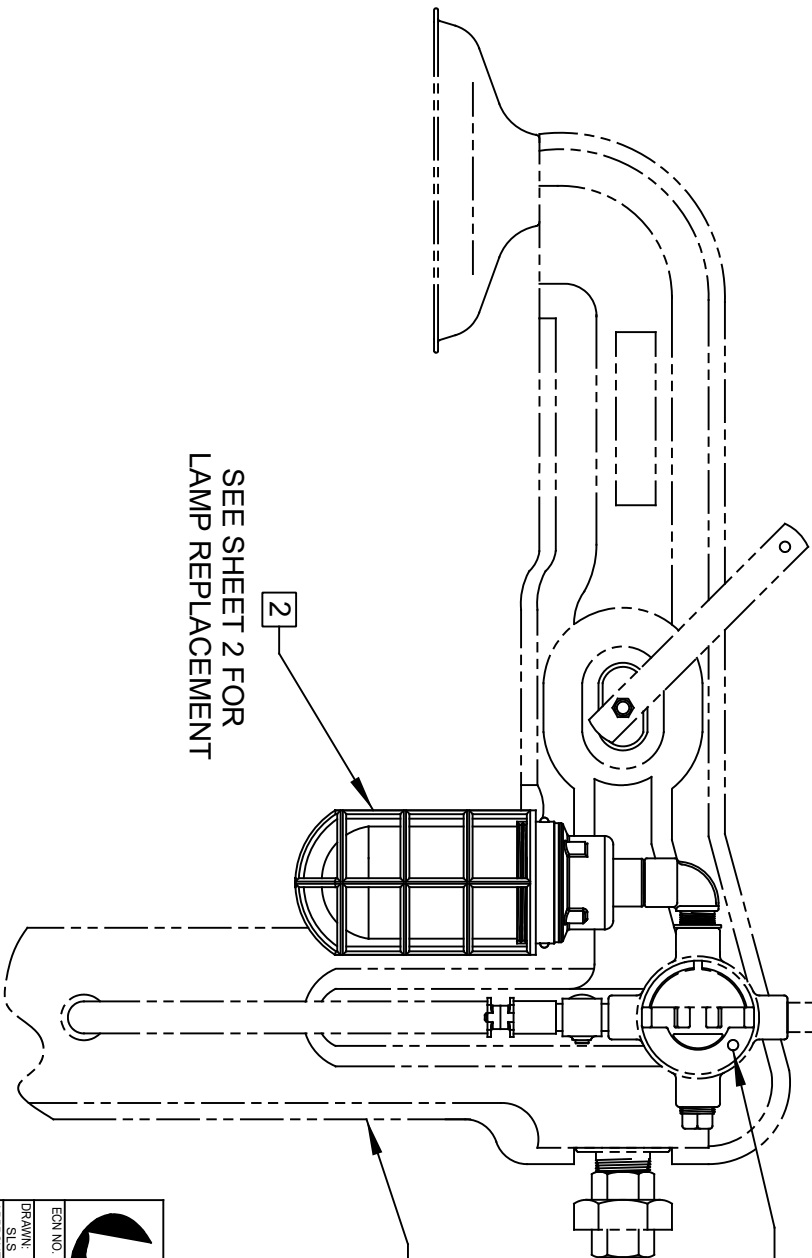

SHOWER SHOWN FOR REFERENCE ONLY (NOT SUPPLIED)

AMBIENT SENSING THERMOSTAT ON 8317CTFP SERIES (NOT SUPPLIED)

SEE SHEET 2 FOR LAMP REPLACEMENT

		<b>Haws</b>	
1459 KLEPPE LANE SPARKS, NEVADA, 89431 (775) 359-4712 FAX (775) 359-7424 E-MAIL: HAWS@HAWSCO.COM WEBSITE: WWW.HAWSCO.COM			
ECN NO. REVISED PER BY:	FV	MODEL(S)	8317LT
ECN: 5775	CHKD: JS	SCALE:	1:1
DATE: 07-09	DATE: 02/22/22	DRAWING TYPE:	INSTALLATION
APPROVED: FV	SCALE:	SIZE:	A
REVISION:	5	SHEET:	1 OF 2
PART NUMBER:	0002080156		

**NOTES: (CONTINUED FROM SHEET 1)**

**2 LIGHT BULB REPLACEMENT INSTRUCTIONS:**

- 1) REMOVE GUARD AND GLOBE:  
FIRST LOOSEN SET SCREW (LOCATED ON GUARD WHERE SHOWN). NEXT, ROTATE GUARD COUNTER CLOCKWISE UNTIL GUARD IS FREE. FINALLY ROTATE GLOBE COUNTER CLOCKWISE UNTIL GLOBE IS FREE AND LAMP IS EXPOSED.
- 2) REPLACE LAMP WITH HAWS P/N 0003225495.  
**WARNING - EXPLOSION HAZARD - SUBSTITUTION OF COMPONENTS MAY IMPAIR SUITABILITY FOR CLASS 1, DIVISION 2.**
- 3) REPLACE GUARD AND GLOBE:  
ROTATE GLOBE CLOCKWISE ONTO THREADS UNTIL SEALED AGAINST GASKET. NEXT, ROTATE GUARD CLOCKWISE ONTO THREADS UNTIL TIGHT. FINALLY TIGHTEN SET SCREW.
- 4) **WARNING: WHEN INSTALLED ON 8317CTFP, THE ASSEMBLY IS ONLY RATED FOR T2C.**
- 5) ALL INSTALLATIONS MUST BE INSTALLED IN COMPLIANCE WITH LOCAL, STATE, AND/OR FEDERAL CODES.

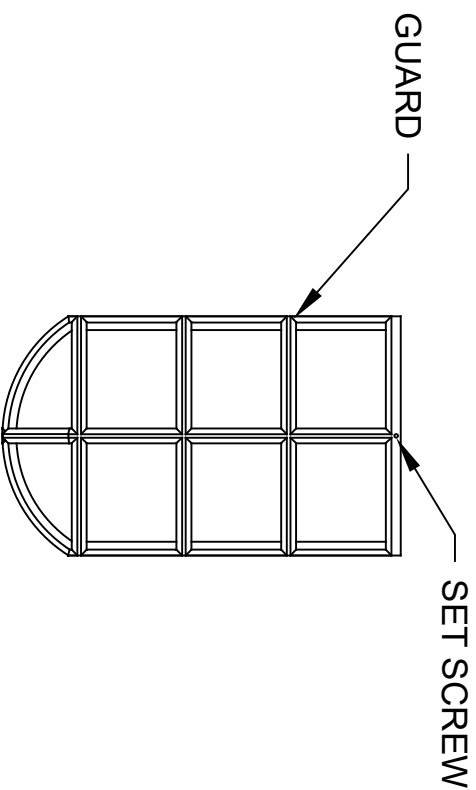
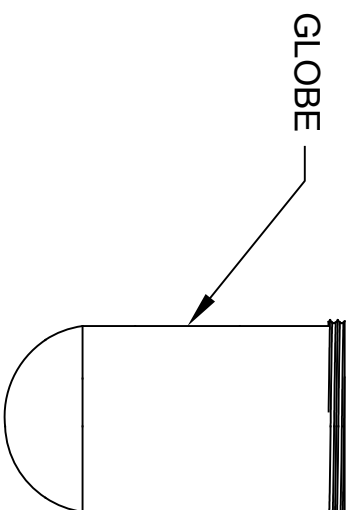
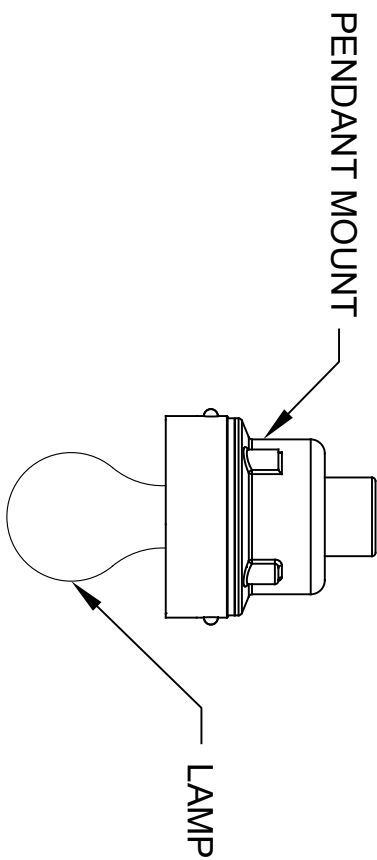

		<b>MODEL(S)</b> 8317LT	
		PART NUMBER 0002080156	
ECN NO. REVISED PER BY: ECON: S775 FV	DATE: CHK'D: 07-08 JS	SCALE: 1:1	DRAWING TYPE: INSTALLATION
DRAWN: FV	DATE: 02/22/22	SIZE: A	SHEET: 2 OF 2
APPROVED: FV	REVISION: 5	1456 KLEPPE LANE SPARKS, NEVADA, 89431 (775) 359-4712 FAX (775) 359-7424 E-MAIL: HAWS@HAWS.CO.COM WEBSITE: WWW.HAWS.CO.COM	