

THIS DOCUMENT IS TRUE AND CORRECT AT TIME OF PUBLICATION. CONTINUED PRODUCT IMPROVEMENTS MAKE SPECIFICATIONS AND MEASUREMENTS SUBJECT TO CHANGE WITHOUT NOTICE.

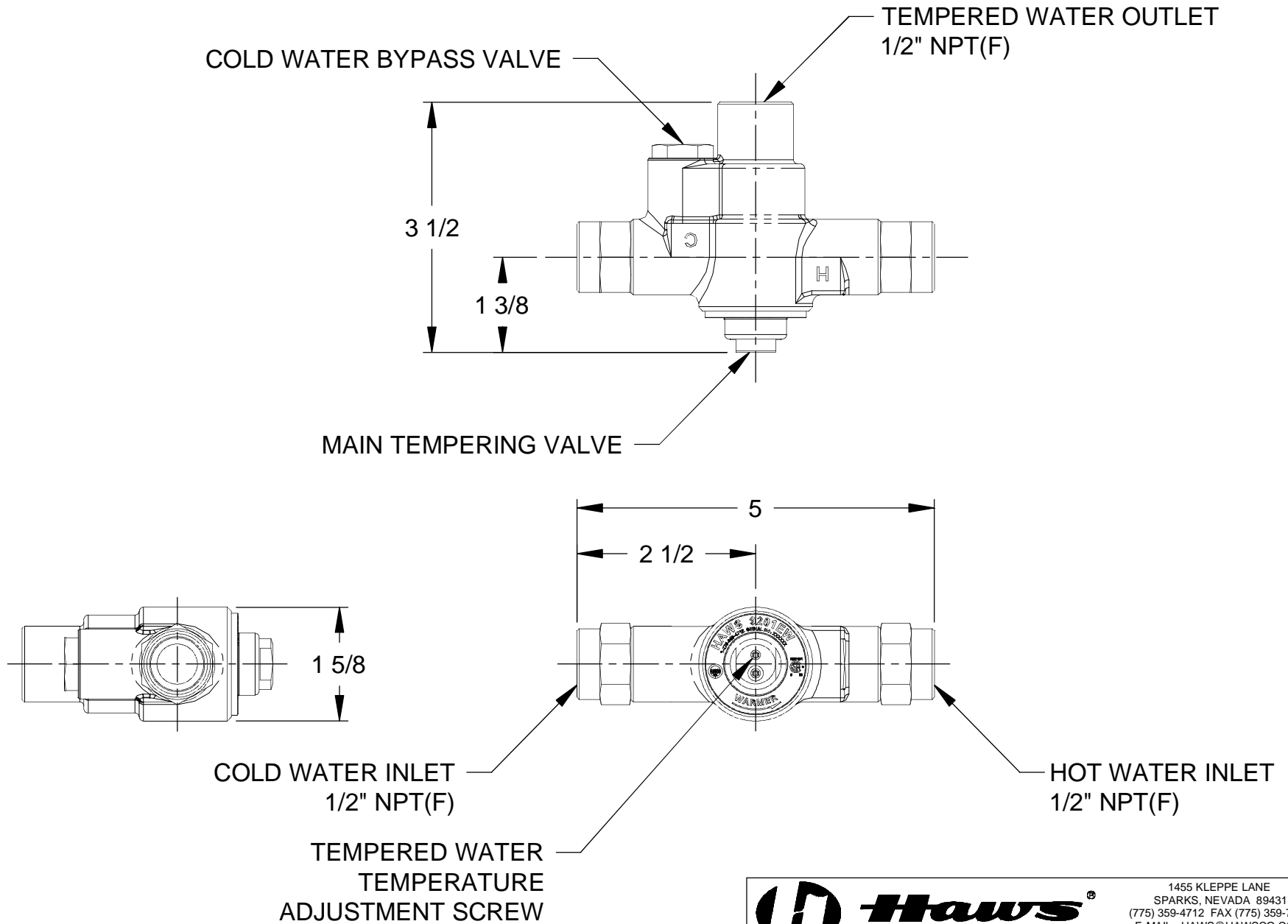

1455 KLEPPE LANE
 SPARKS, NEVADA 89431
 (775) 359-4712 FAX (775) 359-7424
 E-MAIL: HAWS@HAWSCO.COM
 WEBSITE: WWW.HAWSCO.COM

ECN NO. 5055	REVISOR: HM	BY: HM	MODEL(S)	9201EW	PART NUMBER
DRAWN: VWC	DATE: 10/2/12	CHK'D: FV			0002080240.D
APPROVED: FV	DATE: 04/04/16				REVISION
					3