



model TWBS.SHE

AXION® Thermostatic Mixing Valves

FEATURES & BENEFITS

HAWS ORIGINAL

Designed and manufactured by Haws in the U.S.

BYPASS

Best-in-class cold water bypass flow (68% of rated tempered water flow) means continued protection under adverse conditions.

POSITIVE SHUT OFF

Actively suspends hot water flow when cold water supply is lost to protect against scalding.

PRESSURE DROP

Lowest internal pressure drop for this valve class – essential where supply pressure is low.

OPERATING RANGE

Minimal outlet temperature variation is achieved by having the best minimum flow rate in the industry.

SHUTTLE DESIGN

Superior shuttle design combined with premium material selection eliminates valve binding and reduces maintenance costs.

MIXING CHAMBER

Innovative funnel design generates turbulent flow to ensure consistent temperature blending across entire flow range.

LEAD FREE

Certified to NSF61 and California Health and Safety Code 116875 (AB 1953-2006).

FLOW RATES

Flow range of 1 to 74 gpm (280 L) provides service for multiple emergency combination showers or multiple eyewashes to reduce hardware costs.

ANTI-SCALD PROTECTION

Redundant anti-scald protection; primary protection comes from the main tempering valve. An additional high temperature shut-off valve provides a secondary level of protection; the internal cold water bypass takes over to supply cold water in the event of a hot water pressure loss or main tempering valve failure.

MEDICALLY SUPERIOR RESPONSE

AXION's superior design and technology provide a complete safety solution for increased victim comfort.

EXTENDED WARRANTY

3-year extended warranty based on superior engineering and best-in-class material selection means reliable protection you can trust for the long term.



SPECIFICATIONS

Model TWBS.SHE - Thermostatic Mixing Valve (patent pending)

	MAXIMUM		MINIMUM	
Flow Rate	74 GPM	280 LPM	1 GPM	4 LPM
Hot Inlet Temperature	180° F	82° C	120° F	49° C
Recommended Hot Inlet Temperature	140° F	60° C		
Cold Inlet Temperature	70° F	21° C	40° F	4° C
Adjustable Outlet Temperature Range	85° F	29° C	60° F	16° C
Operating Pressure	125 PSI	8.6 BAR		
Factory Temperature Set Point	85° F	29° C		
Cold Water Bypass	50 GPM	189 LPM @ 30 PSID		

Inlet Ports: 1-1/4" NPT(f) Outlet Port: 1-1/4" NPT(F)

Maximum Inlet Pressure Differential: +/- 10%

Listings: ASSE 1071, ANSI Z358.1, CSA B125.3, NSF/ANSI 61-section 8, NSF/ANSI 372, California Health and Safety Code 116875 (AB 1953-2006).

FLOW CAPACITIES

MODEL	INLET	OUTLET	MINIMUM FLOW	INTERNAL COLD WATER BY-PASS AT 30PSI DROP	PRESSURE DROP									
					5	10	15	20	30	45	60	PSI		
TWBS.SHE	1-1/4"	1-1/4"	1	50	.345	.689	1.03	1.38	2.07	3.10	4.13	BAR		
					30	43	52	60	74	91	105	GPM		
					4	189	114	163	197	227	280	344	397	L/MIN



THIS DOCUMENT IS TRUE AND CORRECT AT TIME OF PUBLICATION. CONTINUED PRODUCT IMPROVEMENTS MAKE SPECIFICATIONS AND MEASUREMENTS SUBJECT TO CHANGE WITHOUT NOTICE.

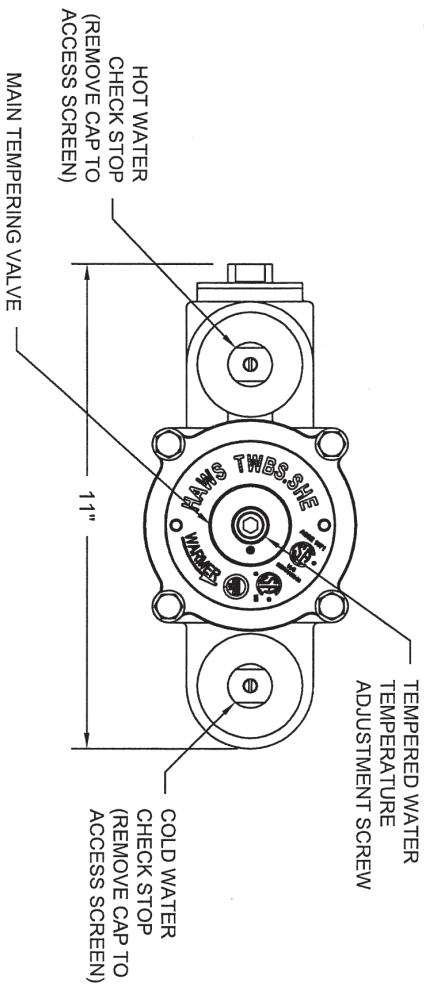
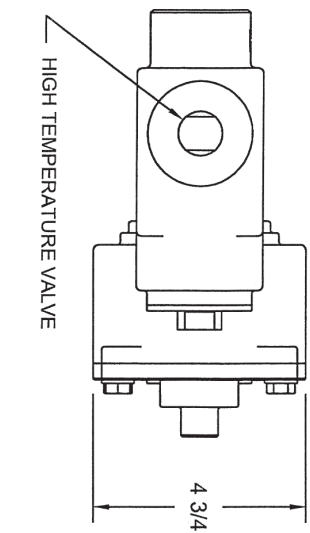
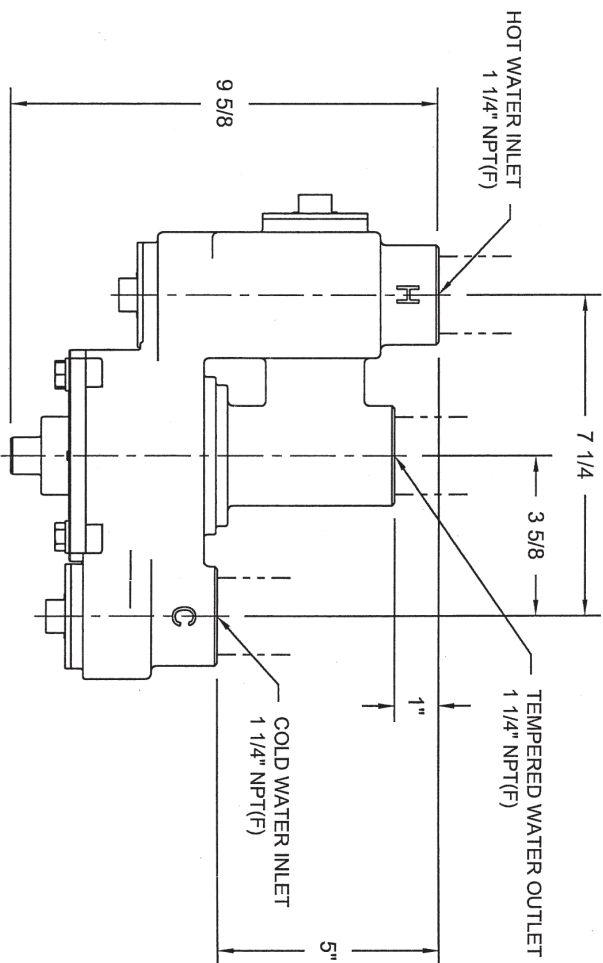

1455 KLEPPLE LANE
 SPARKS, NEVADA 89431
 (775) 359-4712 FAX (755) 359-7424
 E-MAIL: HAWS@HAWS.CO.COM
 WEBSITE: WWW.HAWS.CO.COM

ENCL. NO. REVISED PER:	MODEL(S)	PART NUMBER
DRAWN: ENCL. 752		0002080226 D
APPROVED: DATE: 3/11/11		DRAWING NO. REV
VWC		15965A 4
SCALE: 1:1	DRAWING TYPE: TWBS.SHE	INSTALLATION
SIZE: A	SHEET 1 OF 1	